

SYNTHESIS AND SINGLE CRYSTAL X-RAY DIFFRACTION STUDIES OF Ca_2NF
AND OTHER COMPOUNDS

by

Rhea A. Nicklow

Submitted in Partial Fulfillment of the Requirements

for the Degree of

Master of Science

in the

Chemistry

Program

Youngstown State University

July, 2000

SYNTHESIS AND SINGLE CRYSTAL X-RAY DIFFRACTION STUDIES OF Ca_2NF
AND OTHER COMPOUNDS

Rhea A. Nicklow

I hereby release this thesis to the public. I understand this thesis will be housed at the Circulation Desk of the University Library and will be available for public access. I also authorize the University or other individuals to make copies of this thesis as needed for scholarly research.

Signature:

Rhea A. Nicklow 7/21/00
Rhea A. Nicklow, Student Date

Approvals:

Timothy R. Wagner 7/21/00
Dr. Timothy R. Wagner, Thesis Advisor Date

Allen D. Hunter 7/21/00
Dr. Allen D. Hunter, Committee Member Date

Daryl W. Mincey 7/24/00
Dr. Daryl Mincey, Committee Member Date

Peter J. Kasvinsky 7/25/00
Peter J. Kasvinsky, Dean of Graduate Studies Date

ABSTRACT

Single crystalline nitride-fluoride analogs of the binary oxide CaO, and possibly BaO, were prepared for the first time. The proposed compositions were derived by replacing two O^{2-} ions of the oxide formula with NF^{4-} . After repeated trials, a successful technique for preparing these highly air-sensitive materials for X-ray analysis was developed. Ca_2NF was subsequently characterized successfully via single crystal x-ray diffraction, and was found to be isostructural with $L-Mg_2NF$, rather than CaO, as previously predicted. In other work, crystal structures of three organic compounds were determined via single crystal x-ray diffraction in a collaborative effort with a researcher at the Department of Chemistry, Union College, Shenectady, NY.

ACKNOWLEDGMENTS

My first acknowledgment is to thank my research advisor, Dr. Timothy Wagner, for his endless contribution to this thesis and for his patience throughout my graduate studies. He has positively contributed to my transition from my undergraduate education to my graduate schooling, and I thank him for serving as my general chemistry laboratory mentor, graduate inorganic chemistry professor and most importantly, for being a supportive listener. I would like to thank Dr. Allen Hunter for providing me with an excellent opportunity to gain more experience in crystallography through his collaborative research projects, and for reviewing my work as part of my thesis committee. I wish to thank Dr. Daryl Mincey also for serving as my third thesis committee member, and for always making me feel so welcomed to the YSU Chemistry Department. Another important mentor that I would like to personally thank is Dr. James Mike. I am thanking Dr. Mike because he has given me great insight about how to pursue my future dreams.

I would like to thank my two female chemistry colleagues, Carolyn Pugh and Erica Eliser. These two women have blessed me with their intelligence and laughter. You have both made my days at YSU so memorable, and you have made up for the fun I missed during my undergraduate schooling...

I thank my family: my sister, Tina, and her husband, Alex; my brother, George, and his girlfriend, Lisa; for keeping me up late with humorously intense games of Spades, when I should have been in my room at my computer writing this thesis.

I also thank my Mother and Stepfather, Ginny and Denny, for respecting the value of education and for giving me space, but always letting me know that I am loved.

I wish to thank my friend, Norm Jones also. Thanks to Norm, who has listened and guided my personal growth throughout the past year.

I would like to thank Brian Schmidt. My dear Brian, you have been not only an integral part of my graduate studies, but you have become an irreplaceable spiritual partner. Thank you for your unconditional guidance and love. I found a quote by Epictetus, “The key is to keep company only with people who uplift you, whose presence calls forth your best.” I am blessed because you have this amazing affect upon me.

And finally, I thank God. Thank you God for giving me this opportunity, an opportunity I never would have expected to have been touched by (especially in Chemistry!). And thank you God for allowing me to meet and know all of the above people to guide me through this path, i.e. for allowing me to live an authentic life.

TABLE OF CONTENTS

	PAGE
TITLE PAGE.....	i
SIGNATURE PAGE.....	ii
ABSTRACT.....	iii
ACKNOWLEDGEMENTS.....	iv
TABLE OF CONTENTS.....	vi
LIST OF TABLES.....	ix
LIST OF FIGURES.....	xi
CHAPTERS	
I. INORGANIC SOLID STATE CHEMISTRY.....	1
Introduction to Solid State Chemistry.....	1
Types of Crystalline Solids.....	2
Background of Inorganic Solid State Chemistry.....	3
Challenges of Solid State Chemistry.....	5
Overview of X-ray Crystallography.....	8
Overview of X-ray Powder Diffraction.....	15
Overview of Single Crystal X-ray Diffraction.....	20
II. BACKGROUND OF INORGANIC NITRIDE-FLUORIDES.....	27
Introduction to Main Group Nitride-Fluoride Compounds.....	27
Transition Metal Nitride-Fluoride Compounds.....	29
III. STATEMENT OF THE PROBLEM.....	32

	vii
IV. METHODS AND MATERIALS	34
Introduction	34
Nitride-Fluoride Syntheses	34
Single Crystal Preparation Methods of Nitride-Fluorides	39
Powder Sample Preparation and Data Collection of Nitride-Fluorides	46
Collection of Single Crystal X-ray Data	47
Single Crystal X-ray Data Interpretation of Ca ₂ NF	48
V. EXPERIMENTAL RESULTS	49
Introduction	49
Syntheses of Ca ₂ NF	49
Syntheses of Ba ₂ NF	60
Single Crystal X-ray Analysis of Ca ₂ NF	62
Structure Solution and Refinement	63
VI. DISCUSSION	69
Introduction	69
Polycrystallinity of the Ca ₂ NF Sample	69
Single Crystal Structure Analysis of Ca ₂ NF	72
Bond Valence Sum Method and Analysis Results	74
Future Research Related to Nitride-Fluoride Analogs	78
VII. SINGLE CRYSTAL ANALYSIS OF α -OXY- β -SUBSTITUTED- β -AMINO ESTERS	80
Introduction	80

Background of Organic Structure and Synthesis.....	viii 80
X-ray Diffraction Analysis of Organic Compounds.....	84
Results of Single Crystal X-ray Diffraction.....	88
VIII. CONCLUSION.....	96
REFERENCES.....	98
APPENDIX A.....	101
APPENDIX B.....	104
APPENDIX C.....	113
APPENDIX D.....	124

LIST OF TABLES

TABLE	PAGE
5.1 Crystal Data Summary and Refinement Results for Ca_2NF	64
5.2 Refinements for Ca_2NF	66
5.3 Positional, Occupational, and Anisotropic and Equivalent Isotropic Displacement Parameters From Ca_2NF Final Refinement	67
6.1 Comparison of Powder d-Spacings.....	73
6.2 Bond Valence Sum Results for Ca_2NF	77
7.1 Crystal Data Summary and Refinement Results for 1.....	85
7.2 Crystal Data Summary and Refinement Results for 2.....	86
7.3 Crystal Data Summary and Refinement Results for 3.....	87
7.4 Atomic coordinated and equivalent isotropic displacement parameters for 1	92
7.5 Atomic coordinated and equivalent isotropic displacement parameters for 2	93
7.6 Atomic coordinated and equivalent isotropic displacement parameters for 3	94
A-1 Bond lengths and angles for Ca_2NF	102
A-2 Observed and calculated structure factors for Ca_2NF	103
B-1 Bond lengths and angles for 1	105
B-2 Anisotropic displacement parameters for 1	106
B-3 Hydrogen coordinates and isotropic displacement parameters for 1	107
B-4 Observed and calculated structure factors for 1	108

		x
C-1	Bond lengths and angles for 2	114
C-2	Anisotropic displacement parameters for 2	116
C-3	Hydrogen coordinates and isotropic displacement parameters for 2	117
C-4	Observed and calculated structure factors for 2	118
D-1	Bond lengths and angles for 3	125
D-2	Anisotropic displacement parameters for 3	126
D-3	Hydrogen coordinates and isotropic displacement parameters for 3	127
D-4	Observed and calculated structure factors for 3	128

LIST OF FIGURES

FIGURE	PAGE
1.1 Schematic diagram of X-ray tube.....	10
1.2 The X-ray spectrum obtained from a copper target.....	11
1.3 Derivation of the Bragg equation.....	14
1.4 Diffraction cones obtained from polycrystalline samples.....	17
1.5 Cutaway view of Area Detector.....	19
1.6 Goniometer head in detail.....	22
1.7 Crystal mounting methods.....	23
1.8 A flowchart for the steps involved in a crystal structure determination.....	25
4.1 Glove bag fitted around a binocular microscope.....	40
5.1 X-ray diffraction pattern for Ca ₂ NF synthesis product.....	50
5.2 X-ray diffraction pattern for Ca ₂ NF synthesis product.....	57
6.1 X-ray diffraction pattern for Ca ₂ NF synthesis product.....	71
6.2 Ball and Stick Plot for Ca ₂ NF.....	75
7.1 The reaction pathway for the α -oxy- β -substituted- β -amino ester.....	83
7.2 ORTEP-type plot for 1	89
7.3 ORTEP-type plot for 2	90
7.4 ORTEP-type plot for 3	91

CHAPTER I

INORGANIC SOLID STATE CHEMISTRY

Introduction to Solid State Chemistry

The design and production of most electrical devices from the twentieth century may be accredited to the unique interaction of electrical, mechanical and materials engineering with the field of solid state chemistry. Though the goal of these engineering fields may have been to design and eventually redesign all items requiring electronic devices and intricate circuitry, it has been the standard role of the solid state chemist to create newly innovative materials that would be suitable for such devices in the first place. More recently, solid state chemistry has contributed to the development of electrical devices that are most commonly used in biomedical engineering imaging, biomaterial implants and biocompatible assist devices. Solid state materials are also found in many other products for their optical, magnetic and thermal properties.

Through this wide range of solid state chemistry applications, it may be acknowledged that the solid state chemist has greatly contributed in a positive manner to the overall progress and advancement of knowledge throughout the United States and in other industrialized countries as well. This definite scientific contribution will continue in the future via the creation and design of new materials that are useful to solid state chemists and engineers alike.

Types of Crystalline Solids

Crystalline solids are described according to their bonding characteristics, which may be subdivided into two large categories. These two classifications are: molecular, and non-molecular. Non-molecular solids are further separated into metallic, ionic and covalent network systems.

The main characteristic that distinguishes molecular solids from the other three categories is that they have strong covalent chemical bonds that hold atoms in the molecule together, while relatively weak intermolecular forces adhere separate molecular units to each other. An example of a molecular solid is graphite. Weak forces, viz. low van der Waals forces, shape the structure of graphite contributing to a very stable, low energy system. There is a very low probability for instantaneous dipoles to occur within this molecular solid, and in general the overall structure is unable to be altered and is both mechanically and physically stable.

Non-molecular solids exhibit bonding that may range over the three types of bonding patterns, which each utilize a variety of forces between the particles themselves. Metallic solids involve the bonding of metal atoms, and generally increase in bonding strength as the amount of electrons are increased. As the name implies, ionic solids are composed of ionic bonds, whose forces are created from electrostatic attractions, although ionic compounds often contain appreciable covalent character. And finally, covalent networks are three-dimensional framework structures (like diamond), which are held together by strong covalent bonds. These three types of bonding are most often represented within a three-dimensional system which is referred to as a lattice structure.

The basic building block of this large, ordered repetitive scheme is a unit cell. Unit cell upon unit cell together create this type of non-molecular solid, which is the type of solid state material that is synthesized, characterized and thoroughly analyzed throughout this thesis.

Background of Inorganic Solid State Chemistry

Inorganic solid state chemistry generally relates to compounds which are not composed of carbon in any aspect and are mostly ionic in character. There are four key elements involved in research in the discipline: (1) synthesis (possibly exploratory); (2) structural characterization; (3) property characterization; and finally (4) the calculation and modeling of new materials. The work in this thesis emphasizes the first two of these areas.

The inorganic solid state chemist's approach to synthesis branches in two main directions. The first is a rational design approach, in which a well known system is studied by making slight compositional changes. This usually leads to small changes in structure, but hopefully optimized properties. The other approach is an exploratory one, in which novel compositions are proposed, and then experiments are done by trial and error to determine whether or not the proposed composition actually exists. Note that in solid state chemistry research, it cannot be predicted from the first principles whether a given newly proposed composition may be prepared, and what its properties will be if it is prepared, for that matter.

The exploratory synthesis approach of the inorganic solid state chemist is quite different from other subdivisions of chemistry, such as organic, where reaction mechanisms are well understood and challenges involve mainly yield and purification methods. Inorganic chemistry is opposite in nature to organic chemistry, where all bonds are usually broken and then reformed one at a time. This reforming of bonds makes the organic branch of chemistry a mostly predictable science, allowing it to be presented mechanistically, accounting for all original bonds. Solid state inorganic chemistry is quite different in the sense that bonds of an entire lattice may need to be broken before a reaction takes place. This problem is put into perspective when one realizes that the number of compositions possible for inorganic solids are endless. Any element, except for usually carbon, may be used and the only requirement is that the law of valency be obeyed. While this makes compositions easy to derive, the reason their existence cannot be predicted is due to a lack of knowledge of solid state reaction mechanisms in general, and a lack of data indicating which other related compositions are thermodynamically more stable. Thermodynamic stability is important in high temperature syntheses, which is the most common technique used. This problem will be further discussed in the next section.

As mentioned previously, there are a series of characterization methods that may be utilized following the successful synthesis of a certain solid state compound. Structural characterization occurs mainly through the use of X-ray, neutron and electron diffraction, although spectroscopy techniques are also often used. X-ray diffraction may be further categorized as either single crystal X-ray diffraction or powder X-ray diffraction, and is

the principle characterization technique used in this thesis. This method will be discussed in more detail later. Transmission Electron Microscopy (TEM), and Scanning Electron Microscopy (SEM) are techniques usually used to study crystal chemical defects. Basically, X-ray diffraction gives information related to an “average” structure over many unit cells, while TEM and SEM are used to study structure more locally. Chemical analysis methods include Energy Dispersive X-ray Spectroscopy (EDXS) and Electron Spectroscopy for Chemical Analysis (ESCA). Examples of spectroscopic analysis range from Electron Spin Resonance (ESR) to Nuclear Magnetic Resonance (NMR). Finally, methods of thermalanalysis include Thermal Gravimetric Analysis (TGA), Differential Thermal Analysis (DTA) and Differential Scanning Calorimetry (DSC).

Challenges of Solid State Chemistry

As previously mentioned, the inorganic solid state synthesis work done in this thesis is mostly exploratory in nature. This is because the synthesis routes and structures of the nitride-fluorides studied in this thesis have not been previously well characterized. Some of the challenges of the exploratory synthesis approach are discussed below.

One challenge is the inability to predict the exact composition that will actually occur from a synthesis, due to the wide range of stoichiometry that may exist for specific phases. What is surprising about this first difficulty of solid state inorganic chemistry research is that according to the French chemist Louis Proust, the existence of a compound over a range of stoichiometries is not possible. Around the year 1800, Proust proposed the law of constant composition, and as the name implies, simply states that the

elemental composition of a pure compound remains the same. Yet, the exploratory field of solid state chemistry cannot fully support this statement, because the compositions that result from some syntheses are not found to be constant for a given type of compound. One such example are β -aluminas, which are compounds having the general formula of $M_2O.nAl_2O_3$. In this overall formula n may range from 8 to 11 and M is a cation that may be from the following list: Na^+ , K^+ , Rb^+ , Ag^+ , NH_4^+ , H_3O^+ , NO^+ , Mg^+ and Ln^{3+} .¹ The range of the n in the formula demonstrates how the law of constant composition unfortunately may not always hold true experimentally in solid state materials chemistry.

Another challenge of the exploratory synthesis method relates to the inability to predict which structure and proposed composition one may have synthesized. Indeed, one may end up with both a different composition and structure than predicted. This is due to the fact that the compound of interest may be thermodynamically less stable than another compound with a related composition, which is then preferentially formed. A good example is given by the recent discovery of high temperature superconductors. In 1986, Bednorz and Muller² discovered a new, previously unobserved oxide superconductor, with a then record-high critical temperature of 35 K. This material has the composition $La_{2-x}Ba_xCuO_4$, and is isostructural with K_2NiF_4 . A great deal of research in the field of oxide superconductors was sparked by Bednorz and Muller's discovery, and several new materials were proposed, the most famous of which is the so called 1-2-3 high temperature superconductor. Research leading to the 1-2-3 superconductor began with the knowledge that the T_c of Bednorz and Muller's compound increased with pressure. This implies that T_c should increase as lattice distance decreases, and it was proposed by Chu,³

et al that replacing La (117 pm) with the smaller Y (104 pm) in $\text{La}_{2-x}\text{Ba}_x\text{CuO}_4$ should have decreased lattice distance and thus increased T_c . Chu and his group set out to make the $\text{Y}_{2-x}\text{Ba}_x\text{CuO}_4$, which would presumably also have the K_2NiF_4 structure. The compound actually prepared, however, had the composition $\text{YBa}_2\text{Cu}_3\text{O}_{7-x}$, with a previously unobserved structure related to perovskite. No one could have predicted beforehand that the reaction mixture would yield this particular composition and structure.

It should also be mentioned that in general, if a synthesis attempt is unsuccessful, it cannot be concluded that the proposed compound will not be made if other reaction conditions (e.g. time and temperature) other than those attempted were explored. In general, any solid state reaction occurs from an initial diffusion, followed by nucleation and growth. Kinetically there must be a sufficient amount of energy for the diffusion, nucleation and growth to be possible in the first place.

Although details about the nucleation, diffraction and growth phase of a particular solid state synthesis are typically not known, there are at least some factors a chemist may control to influence the speed, and therefore perhaps the outcome, of a solid state reaction. One such factor is related to the reaction surface area. In general, as the area of contact between reactants increases, so does the reaction rate. This factor is easily controlled simply by using reactant powders with a small particle size, by making sure the reactants are intimately mixed, and by pressing the reactant mixture into a pellet using a hydraulic press. A second factor the synthetic chemist has some control over in influencing reaction rates is related to the nucleation phase. If reactants which have

structures similar to the predicted structure of the product can be chosen, the growth of the product can be facilitated since the matching planes of the reactant lattice will make a good nucleation site. And finally, a third factor is related to the diffusion rate, which is directly related to the reaction rate. The simplest way for a synthetic chemist to influence the diffusion rate is through adjustment of reaction temperature, which has a direct relation to diffusion rate. A rough guide for helping the experimenter determine reaction temperature is given by Tamman's rule, which states that the reaction temperature should be two-thirds of the melting temperature of one of the reactants. Other than these controls, there is not a perfect guideline for solid state chemists to use in order to perform a synthesis. And though these three factors may contribute towards a positive reaction outcome, the actual reassembly mechanism of the reactants to products is usually unknown by the solid state chemist. Thus, there is no means of actually "seeing" what is going on within the structure during the synthesis itself.

As it was discussed before there is more to solid state inorganic chemistry than predicting the synthesis, i.e. there are other major components involved in this field of research. They include the structural characterization, property characterization, calculations and modeling. The next three sections focus on the structural characterization aspect, specifically through the use of X-ray diffraction techniques.

Overview of X-ray Crystallography

X-ray diffraction techniques and methods are fundamental in solid state chemistry research. X-rays are a form of electromagnetic waves, with wavelengths on the order of

10^{-10} m, which are relatively shorter than radio waves or light waves. The first step in generating X-rays involves accelerating electrons from a cathode that bombard a solid material, called the anode. When the solid material is a metal plate, an electron from a core orbital will be ejected, leaving the atom in an excited state. One possible relaxation mechanism the excited atom may undergo involves an electron from a higher energy orbital moving into the inner core orbital to fill it, thus emitting radiation (Figure 1.1). Metals used for anodes in X-ray tubes typically produce wavelengths anywhere from 0.5 to 3.0 Å, or 50-300 pm. An anodic material typically used for the generation of X-rays in a diffractometer is copper, which produces X-rays with a wavelength of 1.54 Å.

Another important aspect of the emission of X-rays is the concept of bremsstrahlung, i.e. the slowing down of the electrons as they are bombarding the metal solid itself. Figure 1.2 demonstrates this with an X-ray spectrum that displays the standard, smooth background line, a bremsstrahlung, in combination with the strong peaks that result for emitted electrons. The labeling of these sharp lines refers to the exact electron shell location that is providing the X-ray. If a 1s vacancy is filled, it is labeled K. This symbol is embellished further by K_{α} , if the transition is from 2p down to 1s, and K_{β} if it is from 3p down to 1s.

This entire concept of X-ray diffraction and X-rays in general were first speculated in the 1890's. The original proposal was that atoms had the ability to pack together into a sphere, which ultimately formed a crystal. At this time it was found that

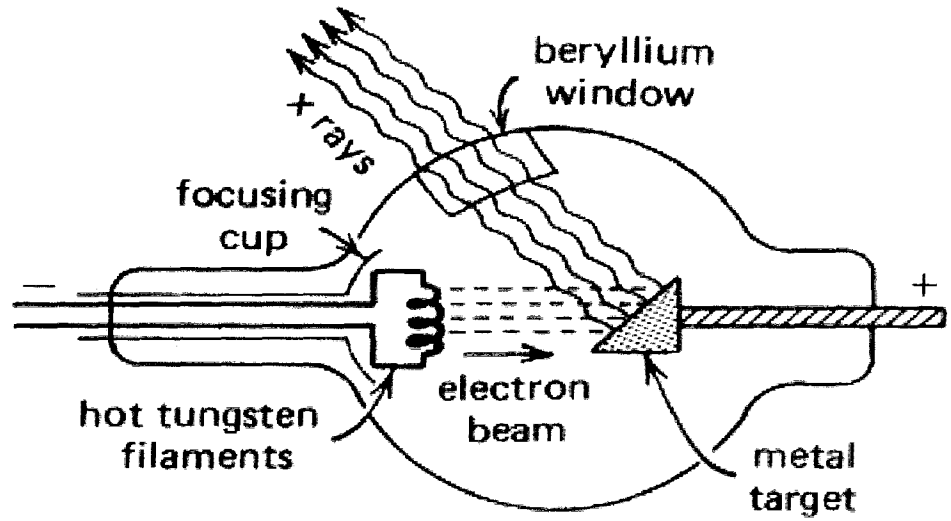

Figure 1.1 Schematic diagram of X-ray tube.⁴

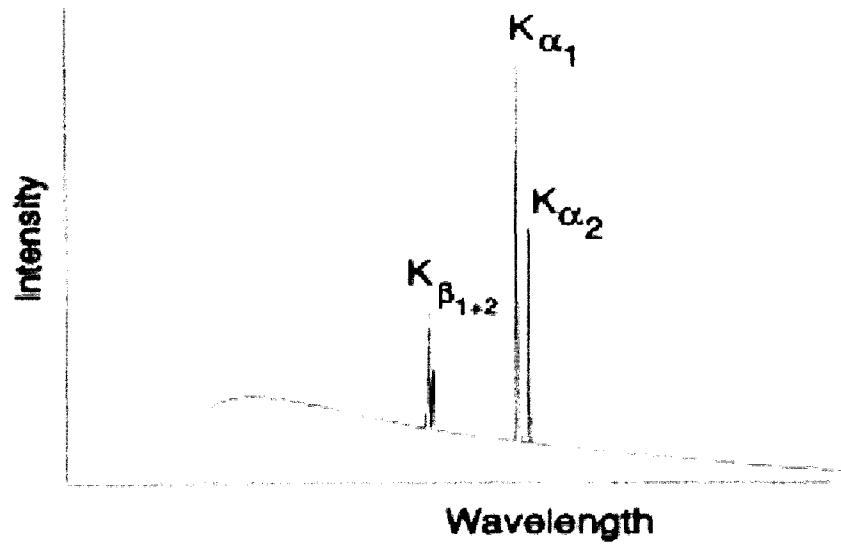

Figure 1.2 The X-ray spectrum obtained from a copper target.¹

X-rays had wavelengths up to 300 pm. This allowed the German physicist, Max Theodor Felix von Laue to develop the concept in 1912 that these crystals could be utilized in the diffraction of X-rays in general. He did not perform his own proposal experimentally, but rather suggested it be completed by two other scientists, by the names of W. Friedrich and P. Knipping. Together these two men proved von Laue's theory to be correct with the use of white X-rays that were experimentally set up to have a wide range of wavelengths. Contrary to these workers, two other scientists testing von Laue's theory chose to perform their experiment with a small range of wavelengths. These two men were the English physicist, Sir William Henry Bragg (1862-1932) and his son Sir Lawrence Bragg (1890-1978).

William and Lawrence Bragg were pioneers in the quantitative analysis and usage of X-ray diffraction in the fields of physics and chemistry. Their original testing included the structures of KCl and NaCl, which were proposed as being fcc (face centered cubic). Lawrence Bragg did indeed discover that his hypothesis of fcc was validated via the X-ray spectrum that was produced. The white X-rays Friedrich and Knipping used in their work yielded data that was difficult to solve due to the wide range of wavelengths present in the incident radiation. Thus, the diffraction patterns produced were full of scattered X-rays from many different planes with a wide range of wavelengths. William and Lawrence Bragg solved this problem by simply using an almost monochromatic X-ray beam with a small range of wavelengths. The results were soon discovered to be directly proportional to the wavelength and the interplanar spacings.

Quantitatively, this may be described by the diagram in Figure 1.3, where certain planes of a crystal are displayed. The angle, θ , represents the angle of incidence of X-rays upon the crystal. The incident X-rays each have a wavelength represented by λ , and are said to be reflected from planes of atoms in the crystalline sample. Some of the beam is reflected from the atoms at the surface, while other portions of the beam will actually penetrate to planes lower in the crystal and will then be reflected. From the diagram it may be inferred that d is the interplanar distance and that the distance $BC + CD$ must be equal to the sum of an integral number of wavelengths represented by $n\lambda$. So, simple trigonometry allows the CD and BC to be represented by the following: $CD = BC = d \sin \theta$. Adding these two together and simplifying gives the Bragg equation: $n\lambda = 2d \sin \theta$.

For a given θ and d , Bragg's Law will be obeyed whenever n is an integer: that is for $n = 1, 2, 3, \dots$, etc. Depending on the value of n , each reflection is called an " n^{th} order" reflection. Note that the value for n is usually set to $n = 1$, and higher order reflections are just those with smaller d spacings. For example, a second order reflection from a given set of planes would have half the d -spacing as the first order set. The different reflections are easily identified using Miller indices. Miller indices, (h, k, l) , are used to represent all sets of planes of atoms in the crystal which diffract X-rays. To obtain Miller indices, the fractions where the plane cuts through the unit cell's a , b , and c axes is first determined, and then the reciprocal of these three numbers are taken. The fractions are cleared and the result is a set of integers which are the Miller indices for that set of planes. For example, a plane which cuts each of the a , b , and c axes of a unit cell in half would be first written as

Wave front
of incoming
X-rays

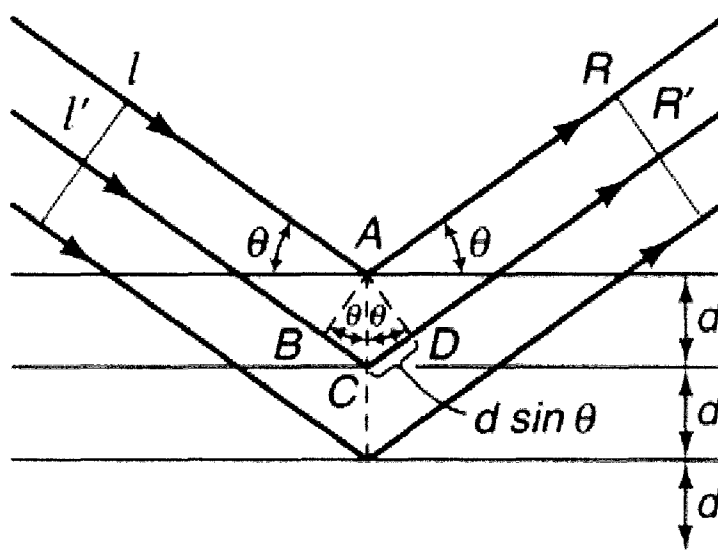

Figure 1.3 Derivation of the Bragg equation, $2d \sin \theta = n\lambda$. The diffraction of X-rays may be considered as reflections from different planes.⁵

1/2, 1/2, 1/2, respectively. Taking the reciprocal of these reflections gives the Miller plane (222), pronounced “the two two two plane.”

The main significance of Bragg’s Law is that it must be obeyed in order for the detector to record a diffraction peak. For a given wavelength, λ , and d-spacing, any angle of incidence other than the Bragg angle results in total destructive interference of the diffracted X-rays, so that no intensity is observed at the detector. From the Bragg angles corresponding to the reflections which are observed, it is possible to deduce the unit cell parameters and symmetry. Though Bragg’s equation was pivotal in the application of X-ray diffraction as an analytical technique, there are three distinct limitations to this equation. The first of these is that Bragg’s Law gives no indication of any systematic absences which may occur in the crystal. There is also no information provided regarding the intensities of the peaks themselves. A third limitation is that Bragg’s Law gives no information about the physics of the diffraction, i.e. the nature of the interaction between the incident X-rays and the electron clouds of the atoms in the crystal.

Overview of X-ray Powder Diffraction

Several types of X-ray powder detectors have been developed since the 1930’s, when the technique first became widely used. The powder sample itself consists of a large number of single crystals that may range in size from 10^{-7} to 10^{-4} m, and are typically positioned in a variety of orientations relative to one another. In order for this method to be performed successfully, the powder sample, the X-ray source, and the detector must all be in the proper alignment. As previously described, diffraction patterns may be

qualitatively analyzed by Bragg's equation. Due to an ideally random positioning of crystallites in the powder sample, the diffracted beams corresponding to a particular set of planes is actually a cone of intensity, rather than a point as expected for a single crystal. In fact, this cone may be considered as a collection of individual points, with each individual point representing a beam diffracted from a single crystallite. The more crystallites there are in the sample, the more points there are to form the cone structure (Figure 1.4). Either a photographic film could be used to capture these points or some other type of device such as an area detector.

One of the earliest powder diffraction techniques commonly used was the Debye Scherrer method, which employs a camera containing a film upon which a large number of peaks are simultaneously recorded. The sample is prepared by filling a small glass capillary tube (e.g. 0.2 or 0.3 mm diameter) with powder. For convenience, the circular Debye-Scherrer camera typically has a circumference of 360 mm, which is also the length of the film strip loaded in the camera. Thus, each mm of film represents $1^\circ \theta$ so that the Bragg angles of the reflections are easily obtained from the film.

The powder diffractometer method is convenient because it does not utilize any film, although relatively large amounts of powder are needed to prepare a sample. This is partially due to the fact that the powder is actually coated on tape affixed to a slide, and pieces of the sample may be lost during the rotation of the sample. Diffractometer data is typically recorded on a diffractogram, which is a graph plotting the intensity of diffracted X-rays versus 2θ . Thus, the Bragg angle for each peak is read directly from the

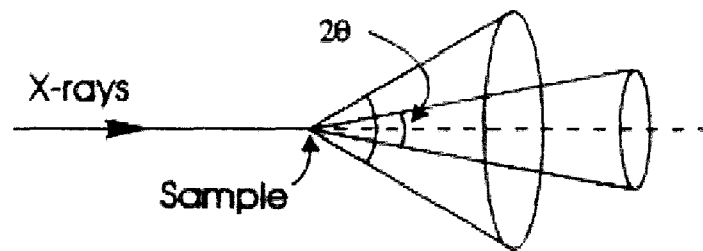

Figure 1.4 Diffraction cones obtained from polycrystalline samples.¹

diffractogram. The technique also has the advantage that relative peak intensities are easily observed, which can be useful in the identification of unknown samples.

The multi-wire area detector is a more recently developed technique used in X-ray powder diffraction, and is the type of detector used for preliminary analysis in this thesis. The multi-wire detector consists of a gas (typically a Xe-CO₂ mixture) filled chamber, which also contains three sets of parallel wire grids as shown in Figure 1.5. The wire grids are charged such that the outer set acts as a cathode, and the middle grid acts as an anode. As an X-ray beam enters this detector, Xe atoms are ionized leaving a positive Xe ion and negative electron. The positive ions are attracted to the anode, while the electrons are attracted to the cathode, creating a potential difference, or signal, between the grid. The detector is efficient enough to register an electrical impulse from one Xe ion-electron pair. During this process distortions inherent to the detector may occur and actually “warp” the resulting spectrum. To eliminate detector errors, correction tables are obtained by performing data collections using standard samples. A real time image is collected in one frame of data that may be merged with other frames to produce an overall spectrum of the sample.

Information from a powder pattern may be used to identify an unknown, (as long as a diffraction pattern for the corresponding known material is available in a database for comparison purposes), determine the atomic positions (i.e. structure) of a sample; or follow the progression of a solid state reaction. The ability to quantitatively refine a single crystal structure from powder data is a more recent development. The major quantitative technique used is Rietveld Analysis. Three items are needed in order for results to be

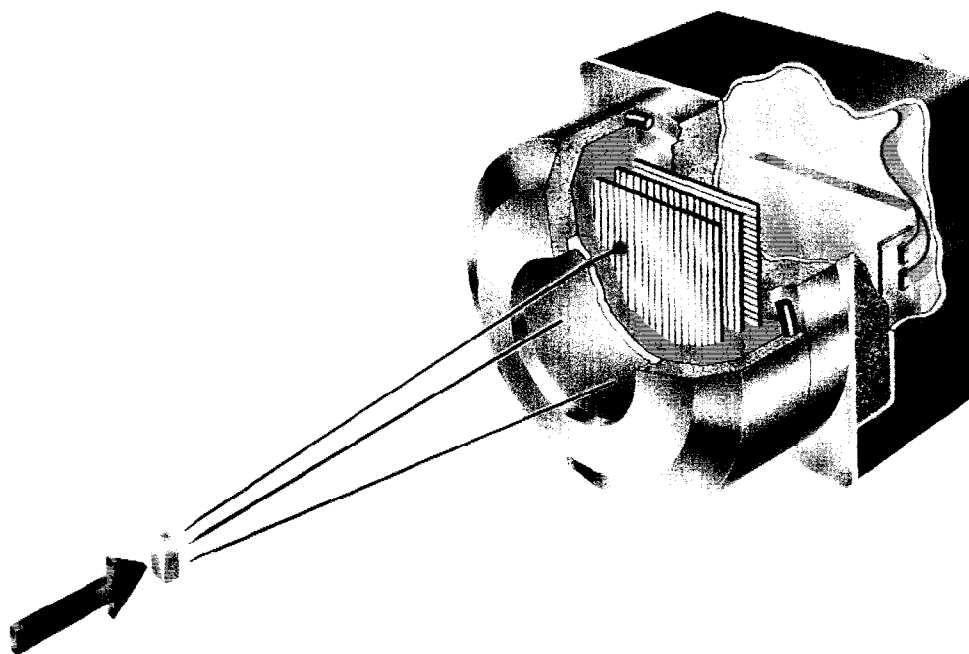

Figure 1.5 Cutaway view of Area Detector. X-rays diffracted from the sample enter the window and ionize the gas mixture. Electronic grids detect the ions and generate electrical impulses which are decoded into position and intensity data.⁶

successfully refined from powder diffraction data: The first is precise lattice parameters, because background is also picked up during the data calculation; secondly, the space group must be known; and thirdly, it is necessary to have a good trial structure before beginning the calculations. The latter two factors make Rietveld analysis more difficult to apply than the typical packages used for single crystal analysis, where structures can be calculated directly with no initial input trial structure requirement. Rietveld analysis calculates the powder diffraction pattern from the given trial structure, and then refines the structure until the calculated and experimental patterns match as closely as possible.

Overview of Single Crystal X-ray Diffraction

Single crystal X-ray diffraction is perhaps the most powerful technique available for structure determinations of crystalline solids. As the name implies, this method of diffraction utilizes one single crystal to determine the structure characteristics of the overall material. A single crystal is defined as a sample that has unit cells that are exactly the same and are all lined up with an identical orientation. If these two items are valid for the sample then the X-rays will create a sharp, clear diffraction pattern. Compared to powder diffraction methods, the overall sample preparation for single crystal diffraction is usually much more difficult and even intricate. Quantitative structure analysis, on the contrary, is much simpler for single crystals than for powder samples as will be evident from the discussion below.

Sample preparation for single crystal X-ray diffraction requires a large amount of hand and eye coordination, as well as patience. The size of the crystal itself will partly

determine the intensity of X-rays that are scattered, though some X-rays are always absorbed by the crystal itself. Since the beam of X-rays generally have a cross section of only 0.5 mm for a typical diffractometer system, it is very important that the sample crystal is directly centered in the line of the beam. In general, a crystal's size should be between 0.1 to 0.4 mm, otherwise absorption becomes a problem. If a crystal is larger than this it may be cut by hand under a microscope with a scalpel, else a smaller crystal must be selected. Once the proper crystal is selected, it is usually mounted with a small dot of glue onto a thin glass capillary tube, which is secured into a goniometer head (Figure 1.6). The glue must hold the crystal into place, due to the fact that it will be rotated in all three dimensions in line of the X-ray beam.

In this thesis project, a variety of crystal preparation methods have been utilized to successfully prepare samples. Standard methods of course include the preparation mentioned above, i.e. a small dot of amorphous glue used to attach the crystal to a thin glass capillary. For air sensitive samples, preparation techniques which protect the sample from air must be used. Examples include enclosing the crystal within a sealed capillary using glue, clay or even encapsulating it in petroleum jelly. Another innovative technique researchers have used is to coat the surface of the crystal with an inert oil (Figure 1.7). Preparation techniques for air-sensitive samples will be addressed at great length in Chapter IV of this thesis, Single Crystal Preparation Methods of Nitride-Fluorides.

Assuming that the sample is a single crystal, if it is mounted properly and is within the view of the X-ray beam with a precision of a hundredth of a degree, the structure will often times be successfully characterized. Data collection is achieved via

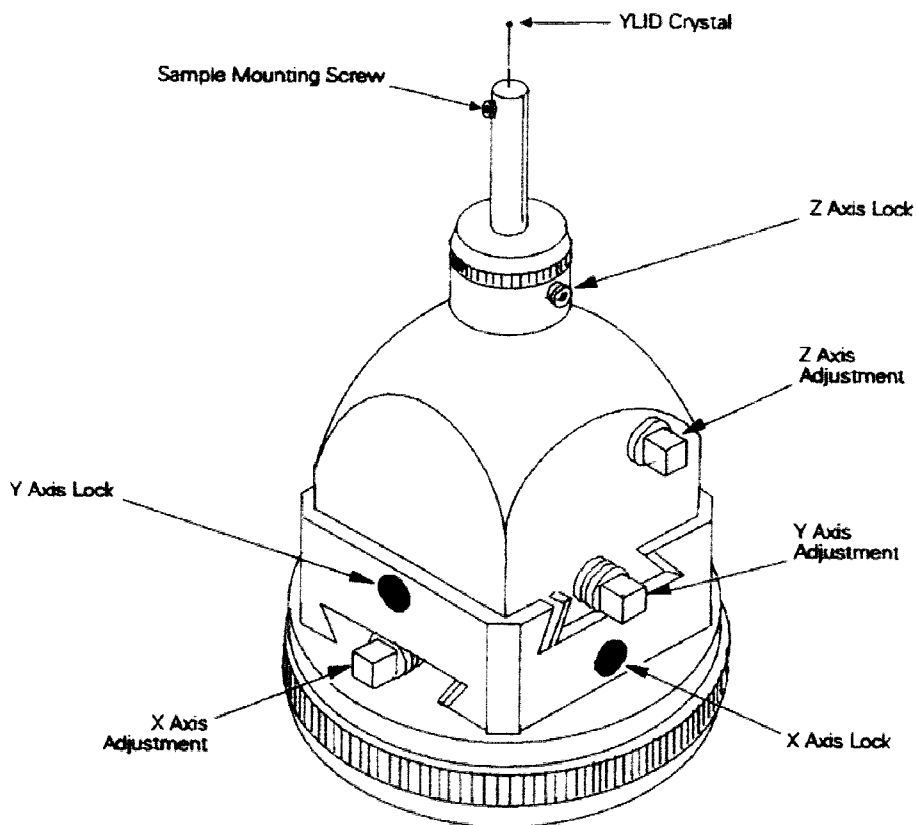

Figure 1.6 Goniometer head in detail.⁷

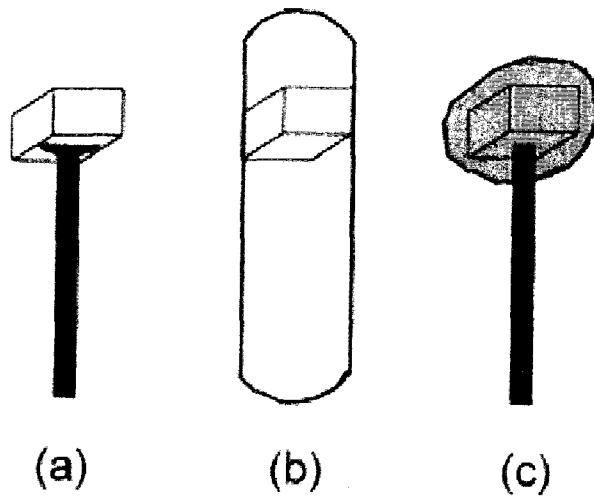

Figure 1.7 Crystal mounting methods: (a) glued to a fine glass fiber; (b) enclosed in a capillary tube; (c) coated with an inert oil.⁸

the scattering of the X-ray beam from the electron clouds present within the atoms in the mounted crystal sample. Generally, several days are required to collect a data set for a sample, using instruments equipped with serial detectors. Data collection is a multi-step process as demonstrated in Figure 1.8. The first step is the collection of a rotation photo to determine the preliminary information about the crystal, such as, is it crystalline? If diffraction spots are found on the rotation photo, these may be centered and used to obtain a rough unit cell and orientation matrix. The next series of steps is concerned with obtaining precise unit cell parameters and the cell symmetry (i.e. Bravais lattice and Laue group). The intensity data is collected next, and depending upon the crystal and its size, and type of detector used, this may take hours or even days. Data reduction follows and absorption corrections are applied to the data set; this is accomplished within a matter of minutes. The structure is then solved via the Patterson or Direct Methods and a few non-hydrogen atoms may be assigned. The Patterson method utilizes the peaks of highest electron density (e.g. from metals in the sample) to determine the structure, while the Direct Methods approach determines reflection phases from intensities when there is no other information about the crystal structure available.⁸ The Direct Methods approach is especially useful for samples with no heavy atoms, such as organic crystals. Next, the structure is refined until all atom positions are assigned. Depending on the experience of the individual, this may take minutes or hours. When the structure is complete, all non-hydrogen and hydrogen atoms have been assigned, and other parameters such as anisotropic thermal parameters, occupancy factors, and/or extinction may be refined as well.⁹ This thesis utilizes the single crystal X-ray diffraction technique to characterize

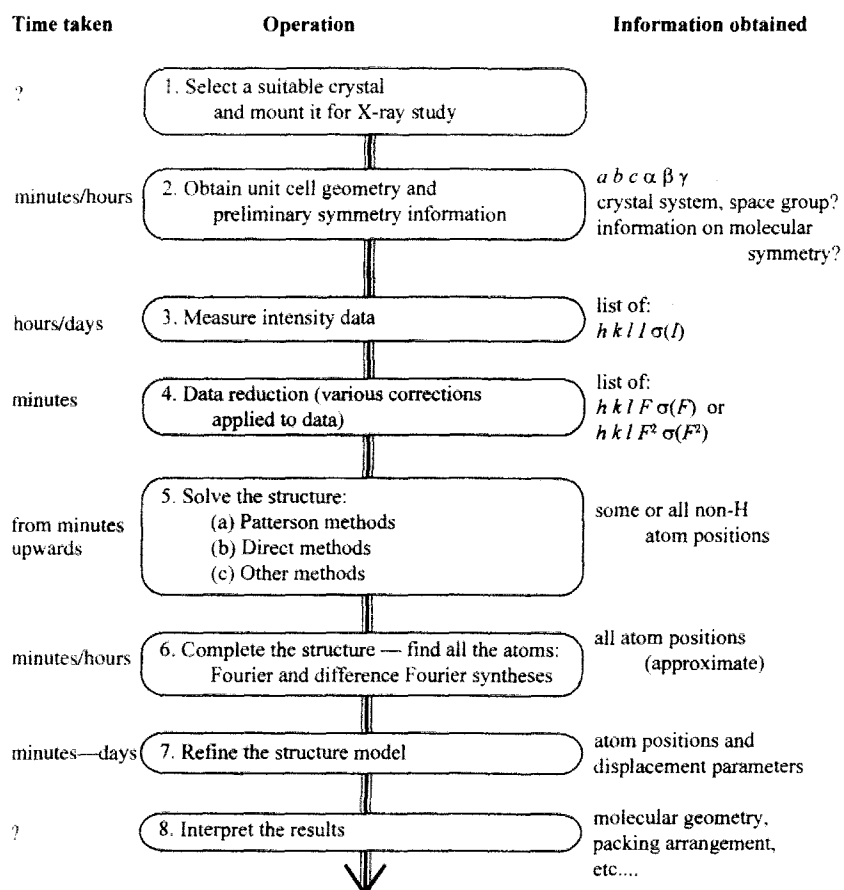

Figure 1.8 A flowchart for the steps involved in a crystal structure determination.⁸

one inorganic crystal and three organic crystals, all of which will be discussed in Chapters V and VI.

CHAPTER II

BACKGROUND OF INORGANIC NITRIDE-FLUORIDES

Introduction to Main Group Nitride-Fluoride Compounds

Inorganic nitride-fluorides have been a relatively unexplored area of solid state chemistry. While tens of thousands of inorganic oxides have been studied, only about forty nitride-fluoride compounds have been reported in the past thirty years. The major characterization technique used in these studies was powder X-ray diffraction. No quantitative structural information based on single crystal analysis has ever been reported on any of these nitride-fluoride compounds previous to this thesis.

The nitride-fluoride compounds of interest in this thesis have ideal compositions that may be derived from oxide compounds by replacing two O^{2-} groups of the oxide formula with an NF^{4-} group. One of the earliest relevant studies was published by Andersson,¹⁰ pertaining to his work on magnesium nitride-fluorides. Andersson prepared his samples by reacting magnesium powder with MgF_2 in a nitrogen gas atmosphere. His work yielded three different phases having two compositions: Mg_3NF_3 , and L- Mg_2NF (low temperature form) and H- Mg_2NF (high temperature form). The L- Mg_2NF and H- Mg_2NF forms were prepared at reaction temperatures of $900^\circ C$ and $1350^\circ C$ respectively. The compositions were deduced by both density measurements and structure determinations. Andersson reportedly found single crystals in some of the final product crucibles, although he noted that they were much too small and delicate for single crystal

X-ray studies to be performed with them. Consequently, structural characterizations were performed via powder X-ray diffraction, where Andersson was able to use powder diffraction to determine the structure of his samples largely through a comparison process with known powder patterns for MgO. Thus, Mg_3NF_3 was found to have an analogous structure to the MgO cubic structure, except that 1/4 of the magnesium sites are reportedly empty, in an ordered fashion. The structure of L- Mg_2NF , when compared to MgO, displayed similar anion positions, but ordering of nitrogen and fluorine atoms resulted in doubling along one of the dimensions of the cubic MgO structure. Thus, the L- Mg_2NF sample was determined to have a tetragonal structure, which was described as intermediate between the sodium chloride (with sodium six-coordinated) and zinc blende (with zinc four-coordinated) structures. In this structure, magnesium is basically coordinated to three nitrogen and two fluorine atoms, with a sixth long bond to fluorine. The H- Mg_2NF sample was found to be isostructural to MgO at temperatures between 1250°C and 1350°C.

Following the reported synthesis of magnesium nitride-fluoride compounds by Andersson,¹⁰ another group reported the synthesis of calcium, strontium and barium nitride-fluorides. Erlich, Linz and Siefert¹¹ conducted this synthesis by using a 3 to 1 mole ratio of the metal to metal-fluoride for the Sr_2NF and Ba_2NF syntheses, and a 4 to 1 ratio for Ca_2NF syntheses. The reaction mixtures were annealed in an inert argon environment at a temperature of 1000°C for 24 hours and then reacted in nitrogen gas for 5 hours at 450°C. Following this treatment, the calcium, strontium, and barium reaction mixtures were sintered in a nitrogen gas flow for 24 hours at 1000°C, 950°C, 700°C

respectively. The Ca_2NF that was found was a light yellow color, although colors of the other two phases were not reported. The products were reportedly characterized using Debye-Scherrer powder X-ray diffraction. The resulting Debye Scherrer patterns suggested the presence of both the MF_2 and M_2NF phases (where M is a symbol for the appropriate metal) in representative lines. From qualitatively comparing the powder patterns of their nitride-fluoride compounds to the corresponding oxides, Erlich, Linz and Siefert concluded that the nitride-fluoride compounds were indeed structural analogs of the corresponding rocksalt-type oxides. Subsequent preliminary studies under the direction of Dr. Timothy Wager, Department of Chemistry, Youngstown State University, Youngstown, Ohio have indicated, however, that this does not appear to be the case for the calcium and strontium nitride-fluoride compounds. Guler¹² prepared Ca_2NF , using the synthesis method as reported by Erlich, Linz and Siefert. A yellow product was obtained, however powder diffraction indicated that the substance did not have the cubic structure as previously reported, but instead appeared to have a tetragonal cell. Potkonicky¹³ synthesized Sr_2NF , and after a thorough analysis of powder data, he suggested that the structure was a combination of the rocksalt and zinc blende structure, as previously reported by $\text{L-Mg}_2\text{NF}$ by Andersson.

Transition Metal Nitride-Fluoride Compounds

In addition to the main group compounds discussed above, some transition metal nitride-fluorides have also been reported, but for the most part, structure characterizations were not performed on these and their structures remain undetermined. In 1971,

Marchand and Lang¹⁴ reported their syntheses of five phases of zinc nitride-fluoride compounds obtained by combining Zn_3N_2 and ZnF_2 in nickel crucibles. These five phases were the following: $\alpha\text{-Zn}_2\text{NF}$, $\beta\text{-Zn}_2\text{NF}$, $\alpha\text{-Zn}_9\text{N}_4\text{F}_6$, $\beta\text{-Zn}_9\text{N}_4\text{F}_6$, and $\text{Zn}_7\text{N}_4\text{F}_2$. Debye Scherrer patterns were used to examine the five phases, however only two of the structural lattices were reported. The $\alpha\text{-Zn}_2\text{NF}$ was found to have an orthorhombic unit cell, and the $\beta\text{-Zn}_2\text{NF}$ compound was found to be tetragonal.

Another group of transition nitride-fluoride compounds that have been referenced in the International Centre for Diffraction Data, *ICDD*, database are those of uranium,¹⁵ thorium¹⁶ and technetium.¹⁷ Though reported, these three compounds were not further characterized by the diffraction data at all, and no specific information about their lattice structure or materials-related characteristics have been reported. Withers, Schmid and Thompson¹⁸ provided some insight into the zirconium nitride-fluoride and uranium nitride-fluoride with a composite modulation approach to structure and space-group symmetries. This has been successful through the analysis of Transmission Electron Microscopy (TEM) and powder X-ray diffraction. Yet again, single crystals were not found or mentioned in the article, and like the above three examples are also in need of future exploration.

More recently, Wustefeld et al.¹⁹ have reported their study of the preparation and structural characterization of titanium nitride-fluoride. A powder sample of titanium nitride-fluoride was prepared by ammonolysis of activated $(\text{NH}_4)_2\text{TiF}_6$, and characterized by Rietveld analysis. The compound was found to be isostructural with the anatase form of TiO_2 , having a body centered tetragonal cell with $a = 3.785 \text{ \AA}$ and $c = 9.514 \text{ \AA}$. This is

probably the most comprehensive structure analysis reported for an inorganic nitride-fluoride compound to date.

Though powder diffraction was used as the main source of characterization of inorganic nitride-fluorides over the past thirty years, single crystal X-ray analysis is still widely recognized as the best method available for elucidating the structure of crystalline solids. Therefore, successful preparation and analysis of single crystals from the aforementioned synthesized compounds would yield significant new structural information in the area of inorganic nitride-fluoride chemistry.

CHAPTER III

STATEMENT OF THE PROBLEM

As mentioned previously, amazingly few inorganic nitride-fluoride compounds have been reported in the literature, and fewer still have been structurally characterized. Of those studies which did include structural characterization, most of them were done using qualitative powder X-ray diffraction. No single crystal X-ray studies on any inorganic nitride-fluoride compounds have been previously reported. Thus, the major goal of this thesis project is to prepare single crystalline samples of M_2NF compounds, and perform structure analyses via single crystal X-ray diffraction.

The nitride-fluoride compounds targeted for study are analogs of the rocksalt type oxide MO , where $M = Ca$ and Ba . The nitride-fluoride compositions are derived from the oxides simply by replacing two O^{2-} ions with NF^{4-} , giving Ca_2NF and Ba_2NF . The reason these compounds have been targeted for study is because they have previously been prepared in powder form,¹¹ so that they are known to exist. Thus, failure to prepare single crystalline samples of these compounds cannot be attributed to the possibility that they do not exist. Inorganic nitride-fluoride compounds tend to be very air sensitive, so that all synthesis work will need to be performed in an inert atmosphere. Once single crystal samples have been successfully prepared, an optimal technique for protecting them from air during X-ray characterization must be devised. The previous study¹¹ qualitatively

proposed that Ca_2NF and Ba_2NF have the rocksalt structure like their oxide analogs; this work will verify quantitatively whether or not this is the case.

In order to gain experience in crystallographic collaboration, the structures of three single crystals, α -oxy- β -substituted- β -amino esters, will be selected and analyzed. These crystals will be provided by James C. Adrian Jr., Assistant Professor of Chemistry, Science and Engineering Center, Union College, Schenectady, New York. High Performance Liquid Chromatography (HPLC) and Nuclear Magnetic Resonance (NMR) have already suggested a likely structure for these samples, which are all enantiomers. The purpose of the present study is to verify the expected structures, and determine which of these stereoisomers are in the anti or syn form, since this is useful information pertaining to the pharmacological properties of these compounds.

CHAPTER IV

METHODS AND MATERIALS

Introduction

Most of the work presented in this thesis is concerned with the synthesis, sample preparation and single crystal X-ray analysis of Ca_2NF . Synthesis attempts for Ba_2NF were also performed and will be presented. This chapter will discuss the techniques utilized in this work in the ensuing sections with subheadings of Nitride-Fluoride Syntheses, Single Crystal Preparation Methods of Nitride-Fluorides, Powder Sample Preparation and Data Collection of Nitride-Fluorides, Collection of Single Crystal X-ray Data and Single Crystal X-ray Data Interpretation of Ca_2NF .

Nitride-Fluoride Syntheses

A variety of reaction conditions and attempts were performed to achieve a successful synthesis of Ca_2NF , while only two syntheses were conducted for the Ba_2NF compound. For all of the syntheses that were conducted, the reactants were weighed, mixed, placed in a nickel crucible and then into a silica tube inside of a plastic glove bag. This bag was kept filled with argon or nitrogen gas in order to ensure a controlled inert environment, since nitride-fluorides are highly air sensitive.

There were nine Ca_2NF syntheses performed overall, usually following the chemical formula $3\text{Ca}_{(s)} + \text{CaF}_{(s)} \rightarrow 2\text{Ca}_2\text{NF}_{(s)}$ in nitrogen gas, $\text{N}_{2(g)}$. Prior to each

reaction, the glove bag was purged of air by flushing with argon for at least ten minutes, then it was sealed and filled again with argon. The bag had one inlet tube, which was connected to a valve switchable between argon and nitrogen tanks. Another tube was leading out of the bag into a beaker full of vegetable oil. The oil served as a filter for excess gas to “bubble” into if that bag was too full. The glove bag was sealed with a simple plastic closure device that was included with the bag, and the plastic tubes were secured with electrical tape and then covered again with parafilm to prevent leakage. Also, an analytical balance, Mettler model PM460, was placed inside the glove bag for weighing the reagents and an opening was cut for the cord to be placed through. This opening was sealed with electrical tape and then covered with parafilm.

For the first Ca_2NF synthesis performed, the reactants were combined in a mole ratio of $4\text{Ca}:1\text{CaF}_2$, following the procedure of Erlich,¹¹ et al. After this initial synthesis, the mole ratio was slightly altered. Syntheses two through nine were conducted with a ratio of $3\text{Ca}:1\text{CaF}_2$. Generally, the calcium metal was first weighed and placed into a 5 mL nickel crucible, and then based upon that amount the correct stoichiometric mass of CaF_2 was weighed out. This was then added to the crucible also. The calcium metal that was purchased was specifically selected because it was finely ground, so that there was no need to grind up the metal with a mortar and pestle. Usually, the CaF_2 powder was placed on top of the calcium metal in the crucible, sometimes it was slightly mixed. Thorough mixing prior to the reaction occurred when the reactants were melted at 1000°C under argon.

Once the mixture in the crucible was covered with a nickel crucible cover, it was placed within a metal boat, also made of nickel. This just stabilized the crucible so that it would not tip over when placed into the silica reaction tube. The crucible and cover were slightly bent to allow the nitrogen gas to enter the container. Inside the glove bag, the boat was gently pushed with a glass rod with a hook on the end into a silica tube, which was then capped with a Pyrex cover. These silica tubes are able to withstand temperatures as high as 1600°C (note that the Pyrex cap end of the tube was not heated). Previous to sealing the glove bag, the tube and cap were coated with a thin layer of vacuum grease to create a secure closure. The Pyrex cap had one outlet and one inlet port where tygon tubes were connected, allowing for dynamic inert gas flow. To avoid any leaks at the silica tube/Pyrex cap junction, the cap was secured to the tube using copper wire. It was very important to prevent any air from leaking into the reaction tube, since this leads to an oxide, rather than a nitride-fluoride synthesis.

Programmable tube furnaces were used for all of the syntheses performed in this project. Syntheses one through four used a Lindburgh Heviduty Tube Furnace, while a Thermolyne 59300 High Temperature Tube Furnace was used for syntheses five through nine. For each synthesis, the silica reaction tube was inserted so that the crucible would be placed in the center of the furnace to provide optimal heating. The synthesis was divided into six steps that were programmed into the tube furnace directly. For each step, three parameters must be specified: the desired temperature level (L#, where # = step number), the heating/cooling rate, or ramp rate (R#), to program the desired temperature level, and the dwell time (D#), which is the desired time to remain at the specified level.

Argon was used as the inert gas for the first half of the reaction, and after Step 3 and just before Step 4, the inert gas was switched from argon to nitrogen by simply closing the inlet into the tube from the Argon gas tank and opening the one leading from the nitrogen gas tank. A typical program for the Ca/CaF₂ synthesis was the following for all nine syntheses (examples for minor changes will be specified in the next chapter):

Step 1: R1: Step; L1: 28°C; D1: 0.0 hours

Step 2: R2: 60°C/hour; L2: 1000°C; D2: 1.0 hour

Step 3: R3: 60°C/hour; L3: 200°C; D3: 4.0 hours

Convert to N₂ gas at this point

Step 4: R4: 60°C/hour; L4: 1000°C; D4: 8.0 hours

Step 5: R5: 15°C/hour; L5: 200°C; D5: 0.0 hours

Step 6: R6: 80°C/hour; L6: 28°C; D6: End of program

Note that the 'Step Function' setting for ramp rate indicates that the furnace is to heat/cool as quickly as possible, as would be the case for a non programmable furnace. The first portion of the synthesis, i.e. up until the change in gas environment from argon to nitrogen, took approximately 35.53 hours total. The rest of the synthesis took 76.81 hours, or 76 hours and 49 minutes to end. The entire program took nearly 111.34 hours, i.e. 111 hours and 20 minutes. It is also important to note in Step 5 that the slow cooling rate is imperative to form single crystals from the melt.

When performing the Ba₂NF syntheses, the same methods were utilized, except that a slightly shorter time in synthesis was programmed. This is because the highest

temperature setting required is only 900°C, instead of 1000°C for the Ca₂NF synthesis.

The Ba/BaF₂ synthesis was performed with the following program:

Step 1: R1: Step function; L1: 28°C; D1: 0.0 hours

Step 2: R2: 60°C/hour; L2: 900°C; D2: 1.0 hour

Step 3: R3: 60°C/hour; L3: 200°C; D3: 2.0 hours

Convert to N₂ gas at this point

Step 4: R4: 60°C/hour; L4: 900°C; D4: 15.0 hours

Step 5: R5: 15°C/hour; L5: 200°C; D5: 0.0 hours

Step 6: R6: 80°C/hour; L6: 28°C, D6: End of program

The first portion of the synthesis took 29.20 hours, or 29 hours and 12 minutes before the gas was switched from argon gas to nitrogen gas. After this it took 75.49 minutes to end, with the total time running approximately 104.69 hours, or 104 hours and 29 minutes.

Again, the same slow cooling method was utilized in Step 5, in order to help grow single crystals during the synthesis.

After each synthesis was complete for both of the aforementioned compounds, the silica reaction tube was allowed to cool thoroughly and was placed into the glove bag. The bag was then flushed of air and refilled again with argon gas. It was then sealed and argon gas was left on with a small, steady flow. The nitrogen gas leading to the quartz tube was turned off and the Pyrex cap removed. A long glass rod with a metal hook attached was used to pull out the boat. A pair of pliers was usually needed to remove the crucible cap from the crucible. The crucible was then placed into a small plastic container, covered with a cap, taped with electrical tape and then covered again with

Parafilm. This was then placed into a larger plastic container, taped, wrapped in Parafilm and was finally labeled according to the compound, synthesis number and date.

Single Crystal Preparation Methods of Nitride-Fluorides

In order to prepare a single crystalline sample for X-ray analysis, another glove bag was set up to secure an inert environment of argon gas for both the Ca_2NF and Ba_2NF . A variety of materials were needed to be placed in the glove bag to aid in the crystal mounting process. Due to the small size of samples to be mounted, it was necessary to place a stereo-microscope partially inside the glove bag, as depicted in Figure 4.1. Portions were cut out of the plastic glove bag to allow for the microscope, light, power supply and cord to fit properly inside and the bag was sealed with electrical tape and Parafilm. Samples were placed on glass slides, and a variety of scalpels, large and small, were used to move the sample around on the slide. Other items inside the glove bag were glass capillaries (glued into brass pins) upon which the crystals were to be mounted, amorphous glue, paper to mix the glue on, and a thin scupula to mix it with. The glass capillaries were prepared by simply pulling glass pipettes over an open flame (i.e. in air) and then cutting off the length desired. Another type of capillaries used were those purchased with sizes 0.1 mm, 0.2 mm, 0.3 mm, 0.4 mm, and 0.5 mm diameters, which were made of either glass or silica. These were utilized by either dropping the crystal into the capillary or by covering the sample mounted with glue on a pulled capillary in the brass pin.

Following the completion of the Ca_2NF syntheses, a sample was opened under

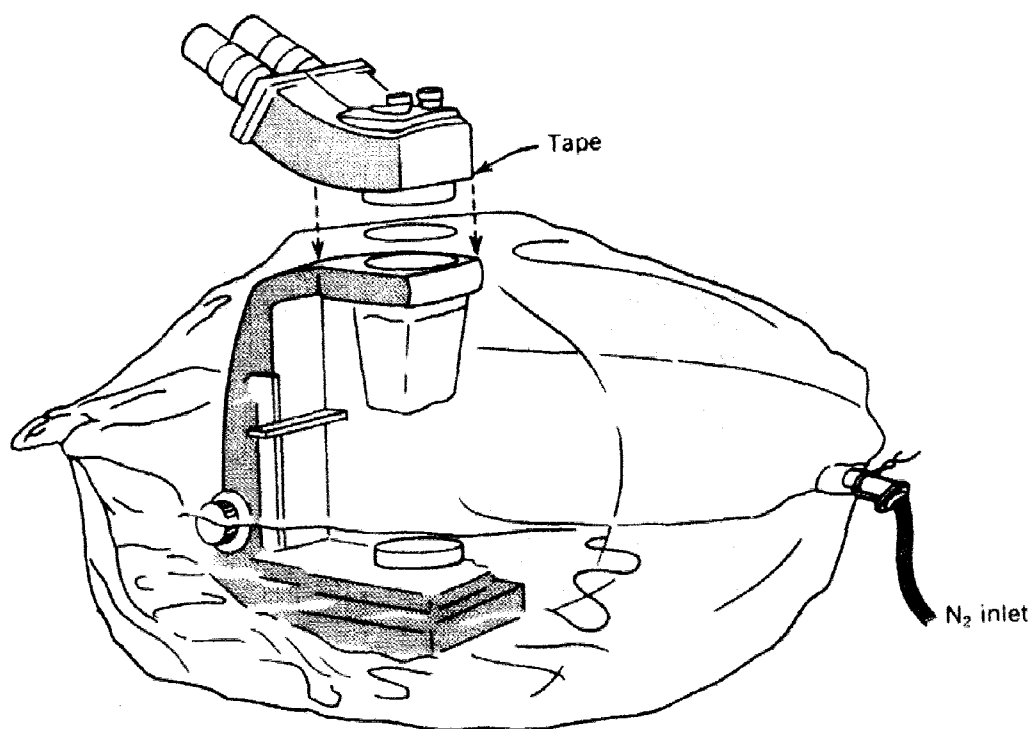

Figure 4.1 Glove bag fitted around a binocular microscope. A hole large enough to fit the eyepiece of the microscope is cut in the top of the glove bag. The glove bag is then fastened to the microscope using electrical tape and purged of atmospheric gases.²⁰

argon in the glove bag and the most yellow portion (i.e. desired product) of the sample was scraped from the crucible and placed on weigh paper. A small portion was left on a glass slide and the remaining sample was put into a clean vial. The vial was placed directly under the gas inlet tube to ensure that it was full of argon gas before it was sealed with electrical tape and parafilm. Crystal selection for X-ray analysis was based upon a few factors to try to ensure that the sample was indeed a single crystal and not twinned or polycrystalline. This included looking specifically for uniform yellow color throughout the crystal with similar dimensions on all four sides of it. (As it turns out, it was quite difficult to select ideal single crystalline samples of Ca_2NF , due to the small sizes of the crystals formed and the resulting difficulty in seeing many details). Also, the crystal selected should not have been dirty with black or gray specs on it and should have no indication of blue, green or clear, colorless portions. And finally, due to the fact that this sample was extremely air (or moisture) sensitive, there was only a limited time available to search for the perfect crystal because of inevitable diffusion of air into the bag. When air found its way into the bag through one of the many openings, the sample turned into a distinctly white powder, which was probably $\text{Ca}(\text{OH})_2$. The probable reaction is: $2\text{Ca}_2\text{NF} + 6\text{H}_2\text{O} \rightarrow 3\text{Ca}(\text{OH})_2 + 2\text{NH}_3 + \text{CaF}_2$. To keep the bag as dry as possible a container of P_2O_5 was kept open inside the bag during sample preparation.

Crystal Mounting Method 1

As it was mentioned in the previous chapter, much effort in this project was focused on finding a way to successfully mount such an air sensitive sample long enough

to conduct an X-ray data collection. The first of these techniques consisted of a slight modification to the traditional capillary/amorphous glue method. Non-air sensitive crystals are usually mounted by touching the tip of a thin capillary glued into a brass pin to the edge of the crystal. This method was slightly altered by placing a larger portion of glue to the tip of the capillary and immersing the crystal in that pool of glue. Moving around the crystal on the glass slide, the crystal became thoroughly covered in the glue and was then picked up off the slide. It was then left to dry inside the glove bag. If there was a tiny portion of the crystal that was not covered in glue, then the crystal's surface became exposed to air, enabling it to turn white. If too much glue was used to mount it to the tip of capillary, then it may have been too thick to even detect the crystal. There is also the possibility that the glue could have reacted with the crystal in certain cases, since some crystals encapsulated in glue seemed to decompose.

Crystal Mounting Method 2

The second method attempted was utilizing glass capillary tubes of sizes 0.1 mm to 0.5 mm to cover the crystal, thus sealing it off from air and protecting it in an inert environment. Depending upon the size of the selected crystal, an appropriately-sized capillary was removed from its packaging with a small pair of tweezers. Under the view of the stereo-microscope, the large top of the capillary was placed close to the selected crystal. A small scalpel was used to push the crystal into the capillary. Once it was placed inside the capillary, the tweezers were used to pick up the capillary to force the crystal deeper into the thin glass tube. Several methods were used to try to cut the capillary,

when the crystal was in its proper place. A scalpel was used to cut the capillary under the microscope, but this harsh movement was often too intense for the crystal, shattering it into many pieces. Clay was also used to plug the top of the capillary, to seal it off so that it may have been completely removed from the glove bag. Once it was outside of the glove bag a pair of tweezers was heated to “cut” the capillary down in size, but the glass was not sealed by the heat. The movement from the tweezers cutting the glass caused the crystal to shatter again. Also, a match was used to try to melt the glass closed at the appropriate location, but the heat damaged the crystal. If the crystal was intact after all of these methods, the capillary was inverted and inserted into a brass pin with either glue or clay. Overall, the crystals were proven to be not only air/moisture sensitive, but also quite susceptible to thermal and mechanical damage.

Crystal Mounting Method 3

Another attempt at mounting these air-sensitive crystals involved wrapping them in a protective layer of aluminum foil. The foil was cut into very small pieces before the glove bag was filled, and a pair of plastic tweezers was used to avoid any ripping or tearing of the foil. Once a crystal was selected, the scalpel was used to pick it up off of the glass slide, and it was then deposited onto the piece of foil. Tweezers were used to gently fold up the foil around the sample and the small ball-like foil was simply glued to the top of a capillary tube. A problem with this technique was that the process of folding the foil around the sample often caused the sample to shatter, and if the foil were folded

more loosely to prevent shattering, the crystal may not have been securely positioned allowing it to roll around inside the foil.

Crystal Mounting Method 4

The next technique attempted again involved enshrouding the crystal inside a capillary tube, but this time in a way that prevented mechanical damage to the crystal upon breaking and sealing the tube. The crystals were first mounted on thin capillaries in standard fashion, and then a 0.5 mm glass capillary was cut and under the microscope was gently placed over the mounted crystal and pushed toward the brass pin. At the brass pin, more glue was dabbed onto the capillary to seal it and to secure it into place. Alternately, the thin capillary upon which the crystal was mounted was secured with clay instead of glue in the brass pin. This allowed for the 0.5 mm capillary over it to simply be pushed into the clay to avoid any air from entering the small glass tube. More glue was added after the sealed sample was removed from the glove bag to try to thickly coat it to improve its chances of surviving long enough in air for data collection. Samples prepared using this method also decomposed before X-ray data could be collected.

Crystal Mounting Method 5

For this trial, a series of glass capillaries of different sizes were pre-cut and inserted into a brass pin full of clay. The top portion of the capillary was open and was used in the glove bag to “pull” in the crystal. With a large portion of glue surrounding the crystal on the glass slide, the open end of the capillary was pushed onto the crystal. If the crystal would not move into the capillary easily, a scalpel was used to aid in its

movement. Once the crystal was encapsulated in glue and embedded just inside the tip of the capillary, it was dipped into another portion of glue to secure it from air.

Unfortunately, this method did not succeed in shielding samples either. The crystals were found to have turned white overnight, verifying that perhaps the glue was reacting with the crystal as suggested from previous observations.

Crystal Mounting Method 6

The method which was finally successful combined many aspects of the techniques described above along with a few new innovations. A very long glass capillary was pulled from the glass pipettes as described earlier and placed in clay inside a brass pin. Inside the glove bag, a small dab of petroleum jelly was used to secure the selected single crystal to the thin capillary. Then, under the view of the microscope, a 0.2 mm silica capillary was fitted over the crystal and the long, capillary was snipped from the brass pin. The large end of the 0.2 mm capillary was temporarily capped with clay and was then removed from the glove bag. In air, the capillary containing the crystal was trimmed to a proper length for X-ray analysis by first immersing the tube inside a large portion of petroleum jelly, which was placed on a glass slide. The open end was covered in petroleum jelly after this trimming and was then plugged with clay. If the other end had still too much length it was shortened in a similar manner. The sample actually used for the single crystal X-ray structure analysis described in Chapter VI was only trimmed on the small end, while the large funnel end of the capillary was plugged with clay and inserted perfectly into the goniometer head without using a brass pin. No interaction

between the crystal and the petroleum jelly was observed, and the sample remained intact for several weeks, enabling the collection of a complete single crystal X-ray data set. It should be noted that using silica rather than glass capillary tubes seemed to be crucial to the success of the method. Each time glass capillaries were used, the sample decomposed, possibly due to the presence of moisture and/or ions in the glass.

Powder Sample Preparation and Data Collection of Nitride-Fluorides

Powder X-ray diffraction was used occasionally during this project mainly to verify that the multi-phase reaction products contained the desired sample. Powder sample preparation is quite simple as opposed to the previously discussed method of single crystal selection and mounting methods. A glass capillary, size 0.2 or 0.3 mm, was utilized to “pack” a powder sample, which was again performed under an inert atmosphere inside a glove bag.

The yellow colored Ca_2NF sample was scraped out of the reaction crucible directly into the mortar itself. Large black impurities that may have been from the nickel crucible were quickly picked out by the human eye or under the microscope. However, this had to be performed as fast as possible due to the fact that the sample only had a distinct amount of time before it reacted. The sample was then ground into a very fine powder with the mortar and pestle and loaded into the capillary tube. As the sample was scooped into the glass capillary, it was “packed” tightly by tapping it gently on a surface or with a finger. Only 1 cm of length of a capillary is needed to complete the sample. It was then cut and inverted into a brass pin with clay.

Data collection and analysis was performed using Bruker's X1000 multi-wire area detector (see Figure 1.5, Chapter I, pg. 19), coupled with the General Area Detector Diffractometer Software (GADDS) Package. Final analysis (e.g. background subtraction, peak assignments, etc.) were done using the DIFFRACT-AT package.

Collection of Single Crystal X-ray Data

Initial collection of Ca_2NF and Ba_2NF single crystal samples were performed on a Siemens (now Bruker) model P4 X-ray diffractometer. Rotation photographs were taken for a number of samples by loading the film cassette into the detector mount and exposing the film to the X-ray generator for anywhere from 10 minutes to 3 hours. After exposure, all of the samples demonstrated very few weak spots, if any at all. Only one sample, a Ca_2NF single crystal, remained yellow long enough to be analyzed further than a rotation photo.

Due to the small size of this crystal, it was taken to the Department of Chemistry, Kent State University, Kent, Ohio to be analyzed with a CCD, charged coupled device system. The CCD detector is ideal for data collection of small, air sensitive crystals such as Ca_2NF , since it is very fast and sensitive. For example, a complete data set for our sample was collected overnight, whereas it would probably have taken a week or longer with the P4 serial detector.

Single Crystal X-ray Data Interpretation of Ca₂NF

All data sets for this thesis project were analyzed using the Bruker SHELXTL package, version 5.05 for Windows NT, on a Gateway 2000 PC-3100XL computer.

The structure was solved using direct methods and refined by the full-matrix least-squares on F² technique. The refinement parameters included correction for secondary extinction, and anisotropic thermal parameters on all atoms. The extinctions that were refined in later cycles and the weighting scheme used was that suggested by SHELXTL-XL. Occupancy factors were refined on all atoms as well. Molecular graphics and tabular data were generated with SHELXTL-XP and SHELXTL-XCIF.

CHAPTER V

EXPERIMENTAL RESULTS

Introduction

The results and details of each Ca₂NF and Ba₂NF synthesis performed will be described in this chapter. In addition, structural analysis of Ca₂NF from single crystal X-ray diffraction data will be thoroughly discussed. The overall reactions, as well as the number of trials, for each of the two nitride-fluoride syntheses studied in this thesis are summarized below:

Reaction 1: $3\text{Ca}_{(s)} + \text{CaF}_{2(s)} \rightarrow 2\text{Ca}_2\text{NF}_{(s)}$ in nitrogen gas, N_{2(g)}

Trials Performed: 9

Reaction 2: $3\text{Ba}_{(s)} + \text{BaF}_{2(s)} \rightarrow 2\text{Ba}_2\text{NF}_{(s)}$ in nitrogen gas, N_{2(g)}

Trials Performed: 2

Syntheses of Ca₂NF

The overall reaction for synthesis of Ca₂NF listed above was discussed in detail in Chapter IV, in the Nitride-Fluoride Syntheses sections. For most of the nine trials completed, the final product mixture consisted mainly of unreacted CaF₂ powder and Ca₂NF crystals, as indicated in the powder diffraction pattern shown in Figure 5.1. Sometimes nickel (from the crucible) was found as well. Each of the nine trials will now

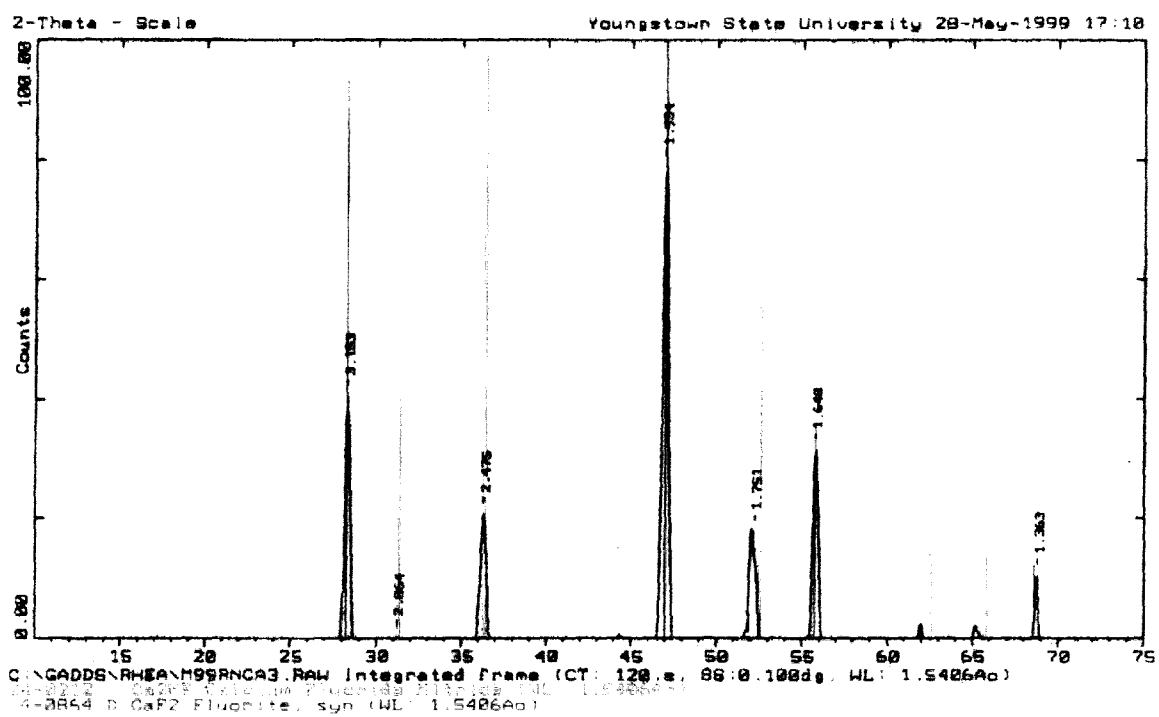

Figure 5.1 X-ray diffraction pattern for Ca_2NF synthesis product.

be described according to the masses of the reagents used, mole-to-mole ratios, and synthesis results.

Trial 1

This first synthesis used calcium metal pellets that were very large and could not be crushed with the mortar and pestle. Thus, three pellets were weighed to a mass of 0.486 g, corresponding to 0.012 moles of calcium. The grams of CaF_2 needed was calculated to be 0.237 g based on the mole ratio of $4\text{Ca}:1\text{CaF}_2$ used for this trial. As the calcium pellets were too difficult to crush with the mortar and pestle, the reactants were simply placed together in the crucible without mixing.

The synthesis was first attempted with a slight difference in Step 5 of the furnace program as reported in Chapter IV, page 37. Step 5 for this trial utilized a cooling rate of $20^\circ\text{C}/\text{hour}$ instead of $15^\circ\text{C}/\text{hour}$ as used for later trials, to promote crystal growth. Though this rate was slightly faster for the first synthesis, yellow crystals were found and were mounted using the Single Crystal Mounting Method 1, described in the last chapter, pg 41. Thus, the crystals were just mounted on a thin capillary and encapsulated in amorphous glue. All of the crystals that were mounted eventually decomposed due to extreme air sensitivity. This was detected by the crystals turning from yellow to pale yellow to white over a short period of time ranging from an hour to a day or so. From this first trial, there was one crystal that was mounted and continued to appear yellow in color long enough for a hemisphere search to be taken. The sample was too small (0.02 mm in the largest dimension) for further analysis at Youngstown State University, and so it was

sent to the Department of Chemistry, University of Toledo, where it was inspected via a single crystal X-ray diffractometer equipped with a CCD. Despite its small size, the sample was found to be polycrystalline and it gave poor data, such that it could not be further characterized. In fact, it was not even possible to verify that the crystal was the desired Ca_2NF phase.

Trial 2

The next trial that was performed used a slight variation of Reaction 1 (see above) by changing the mole-to-mole ratio from $4\text{Ca}:1\text{CaF}_2$ to $3\text{Ca}:1\text{CaF}_2$. This is the exact stoichiometric ratio needed to give the desired product: $3\text{Ca} + \text{CaF}_2 + \text{N}_2 \rightarrow 2\text{Ca}_2\text{NF}$. Thus it was predicted that a complete reaction should yield only the desired product with no impurities. However, a complete reaction was never observed; the final product always contained unreacted CaF_2 . Again, calcium pellets were used for this trial, and so the pellets and the CaF_2 were simply added together into the crucible without any mixing in the mortar and pestle. The mass of three calcium pellets was 0.580 g, and this was used to determine the mass of CaF_2 needed. This amount was 0.348 g CaF_2 . The rest of the synthesis was performed exactly the same as that of Trial 1.

Yellow single crystals were found in the crucible, and a small amount of blue single crystals were found also. Samples of both colors were mounted with the same method as utilized in Trial 1, however none of the samples survived and all turned white overnight after being mounted. The blue crystals found were perhaps a nickel nitride-fluoride phase or another phase of calcium nitride-fluoride that has never been previously

reported. Binary nickel-fluoride, nitride or oxide phases were all ruled out as possibilities, since none of these have the deep blue color of the observed crystals. Powder X-ray analysis was also attempted from this synthesis, but after packing the sample, it was oxidized and turned white too.

Trial 3

The calcium metal reactant used in this synthesis and for the remaining trials was a pre-ground calcium powder, enabling pre-mixing of the reactants before synthesis, as well as an increased surface area of contact for the reactant particles during the synthesis. The nickel reaction crucible contained 1.195 g of calcium and 0.810 g of CaF_2 , in an approximate 3:1 mole ratio of Ca: CaF_2 . The standard furnace program described in Chapter IV was used, and both yellow and blue crystals were found in the crucible after the completion of the synthesis. The main crystal mounting technique used for this trial was that of dropping the crystal into a glass capillary ranging from 0.1 mm to 0.5 mm in size and then either cutting the glass, or plugging it with clay and sealing it off with a match, (i.e. Crystal Mounting Method 2 from the previous chapter, page 42).

One yellow single crystal sample did remain intact after cutting the capillary in the glove bag and inverting it into glue. After a rotation photo proved unsuccessful with only three weak sets of points on the film, hemisphere and thin shell searches were performed, yet no additional peaks were obtained. Most likely, the crystal was polycrystalline or was much too small to be analyzed via the P4 Siemens diffractometer.

Another method of single crystal preparation for this trial was that of the aluminum foil method as described in Chapter IV (Crystal Mounting Method 3, page 43). After a yellow crystal was prepared, a hemisphere search was performed, but no data was obtained from this. The sample was most likely moving inside the foil ball, and unfortunately there was no way to ensure whether or not the crystal inside the foil was stable. For this reason, this method for mounting crystals was not pursued further with samples from trials four through nine.

Trial 4

For this trial, the masses of the reagents were 0.616 g of Ca metal and 0.400 g of CaF_2 with a mole-to-mole ratio of $3\text{Ca}:1\text{CaF}_2$. In an attempt to obtain larger crystals, the cooling rate was decreased during this synthesis compared to trials one to three. Specifically, Step 5 in the furnace program (see page 37) was altered to cool at a rate of $10^\circ\text{C}/\text{hour}$ instead of $20^\circ\text{C}/\text{hour}$.

After the synthesis was complete, a leak from a crack was found in the glass tube as evidenced by a layer of white powder deposited on the inside and outside of the tube. Some yellow Ca_2NF crystals were still obtained, but they seemed to decompose more quickly than usual. Nonetheless, several yellow crystals and a blue crystal were mounted by dropping the crystals into glass capillaries ranging in sizes of 0.1 mm to 0.2 mm (i.e. see Crystal Mounting Method 2, page 42). Only two yellow crystals were analyzed on the diffractometer. For the first sample analyzed, only two peaks were found during the hemisphere search, probably due to too much crystal damage from a match singeing the

end of the glass capillary during the mounting process. Another yellow crystal revealed no points on a rotation photo after an exposure time of two hours, and a blue crystal did not provide any peaks during a hemisphere search.

Trial 5

For this trial, 0.560 g of calcium metal was mixed together with 0.346 g CaF_2 inside the crucible (approximately a 3:1 mole ratio). Step 5 of the furnace program on page 37 was slightly altered to $15^\circ\text{C}/\text{hour}$, which was slightly faster than the previously performed synthesis. During the synthesis the plastic tube supplying the argon gas to the tube furnace had slid off from pressure. This opened the system to the air and contaminated the sample. Therefore, the fifth synthesis was unsuccessful and there were no crystals mounted from this trial.

Trial 6

With the same mole ratios and program as used in Trial 5, the Ca_2NF was prepared with 0.591 g Ca metal and 0.384 g CaF_2 . After the synthesis was complete, the crucible was opened and inspected and yellow crystals were present. The crystals for X-ray analysis were selected and mounted using two different techniques, (viz. Methods 4 and 5, page 44) discussed in Chapter IV, however all of the crystals decomposed overnight. Blue/green crystals were also mounted using Method 5, but did not retain their color after preparation either.

Trial 7

Again in a 3:1 mole ratio of Ca:CaF₂, 0.641 g Ca metal and 0.416 g CaF₂ were mixed together in a crucible, and reacted using the standard furnace program described in Trial 5. After the completion of the synthesis, both yellow and blue crystals were observed in the reaction crucible. The few blue and yellow samples that were mounted utilizing the method of sample preparation as described in Trial 6 were somehow exposed to air and decomposed before X-ray data could be collected.

Trial 8

For this trial, three crucibles were placed in the furnace tube to maximize the amount of yellow Ca₂NF product. The masses of each of the reactants in each of the crucibles are listed below:

Crucible A: 0.598 g calcium metal, 0.388 g CaF₂

Crucible B: 0.592 g calcium metal, 0.384 g CaF₂

Crucible C: 0.576 g calcium metal, 0.374 g CaF₂

Each of these crucibles upon examination after the synthesis contained a large portion of yellow single crystals. Powder samples were prepared from this trial due to the fact that there was a large amount of product readily available for this method of evaluation. Two 0.3 mm glass capillaries were filled with yellow powder with the hope that the sample was pure enough to provide data that could be used for structure refinement by Rietveld analysis. As seen in the powder pattern shown in Figure 5.2, however, the sample (despite its yellow color) consisted largely of CaF₂. This could be due to the unreacted CaF₂, or more likely indicates decomposition of the Ca₂NF.

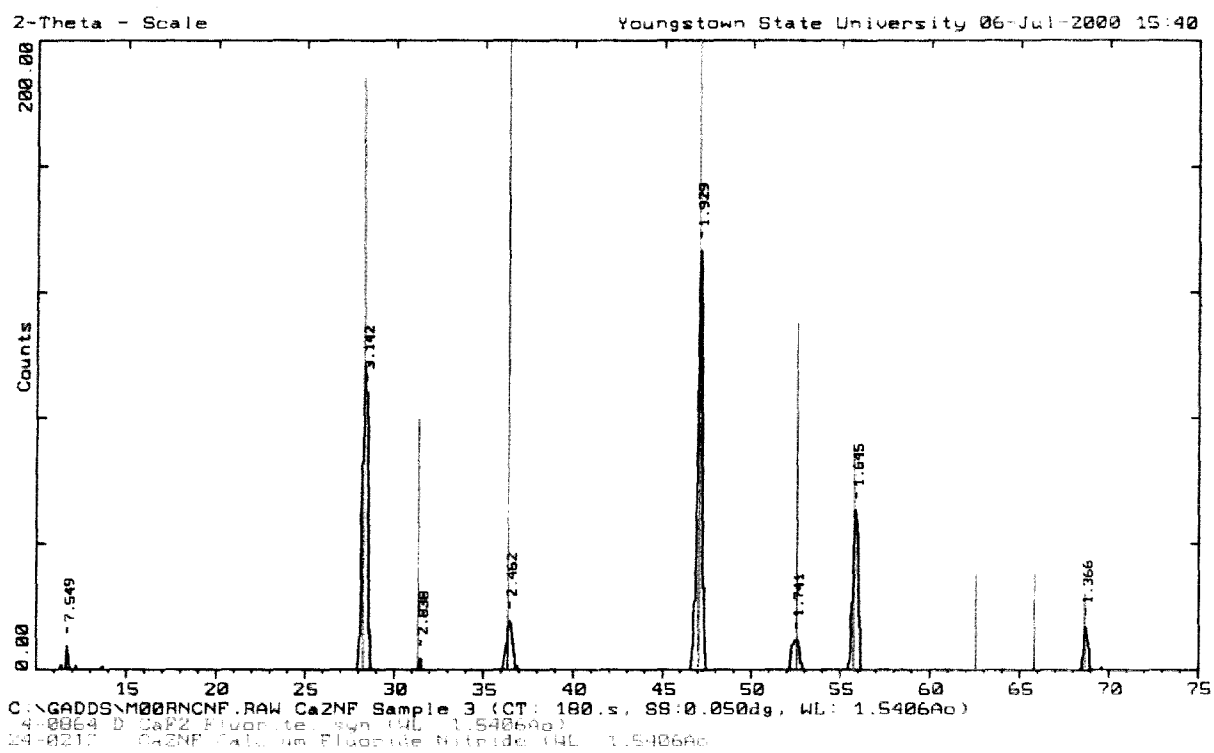

Figure 5.2 X-ray diffraction pattern for Ca_2NF synthesis product from Trial 8.

Attempts to isolate yellow particles and prepare a powder sample from these failed, mainly because the sample decomposed (in the glove bag) before a sufficient amount of the tiny particles for powder diffraction could be gathered. When left out of the glove bag overnight the samples, although packed in a capillary tube, both reacted with air and turned into a white powder, as observed previously for Ca_2NF single crystals. Single crystals were mounted also from this sample but were unsuccessful. One final triple synthesis was performed and will be describe in detail next.

Trial 9

This synthesis was the last performed and utilized a slight variation of the programs that were previously utilized.

Step 1: R1: Step function; L1: 28°C; D1: 0.0 hours

Step 2: R2: 80°C/hour; L2: 1000°C; D2: 1.0 hour

Step 3: R3: 100°C/hour; L3: 200°C; D3: 3.0 hours

Switch from Ar to N₂ gas at this point

Step 4: R4: 80°C/hour; L4: 1000°C; D4: 4.0 hours

Step 5: R5: 60°C/hour; L5: 200°C; D5: 0.0 hours

Step 6: R6: Step function; L6: 28°C; D6: End of program

Steps 2-6 were each different than the program presented in Chapter IV, page 37. This final program took 24.5 hours until the gas was changed from argon gas to nitrogen gas, with the entire synthesis taking approximately 60 hours.

The three crucibles used in the synthesis were placed in the tube furnace as in Trial 8 and the masses of the reagents (all in approximate 3:1 mole ratio of Ca:CaF₂) are listed below:

Crucible A: 0.560 g Ca metal, 0.364 g CaF₂

Crucible B: 0.555 g Ca metal, 0.360 g CaF₂

Crucible C: 0.554 g Ca metal, 0.359 g CaF₂

After the synthesis was complete, each crucible displayed a large amount of yellow crystals. A few powder samples were prepared with this yellow Ca₂NF and they were not successful in the glass capillaries and turned white soon after packing the samples. Thus, attention was once again turned to mounting single crystals.

At this point, it was apparent that the Ca₂NF samples were not stable while in contact with neither the glass capillary mounting/packing tubes, nor with the epoxy used to secure/encapsulate them. The glass capillary tubes may have had a high water content and once used inside the glove bag, this water may have aided in the decomposition of either the powder or single crystal samples that were prepared, turning the sample to a white powder substance or white crystal. In addition, the glass capillaries may also have had a sufficient cation content (e.g. Na⁺), to interact with F⁻ ions in Ca₂NF, and cause it to decompose. The epoxy was not further analyzed to determine a cause for the apparent instability of Ca₂NF when placed in contact with it. Thus, for this trial, pure silica capillary tubes (0.1 mm and 0.2 mm in diameter) were used instead of glass to avoid the formation of calcium hydroxide and to secure an inert environment. Also, petroleum jelly was used instead of epoxy to mount the crystal to the thin glass capillary to secure the

crystal. Since the glue may have been reacting with the single crystal, the petroleum jelly was more effective at holding the crystal at the proper site and keeping it yellow in its nitride-fluoride form. The sample was cut to a shorter, more effective length outside of the glove bag in a protective drop of petroleum jelly on a glass slide. The jelly was also an extremely effective shock absorber, allowing the crystal to remain in its argon environment without crumbling or breaking apart at all.

One specific sample mounted in this way remained yellow for over a week, which was long enough for the entire single crystal X-ray diffraction data collection to be performed on the sample. As previously mentioned, the sample was taken to Kent State University, Kent, Ohio, where a diffractometer equipped with a CCD detector was used for data collection. Though it was found that the sample was not single crystalline, a good unit cell and conclusive structure was obtained using about half of the data collected, as discussed shortly.

Syntheses of Ba₂NF

Two trials were attempted for the synthesis of Ba₂NF single crystals. Since the color of Ba₂NF has never been previously reported, selecting crystals for mounting was difficult relative to the case for Ca₂NF, where the expected color was known. Most often, pink crystals were selected and mounted for analysis, although clear, colorless crystals were also present and sometimes mounted. The two trials for this compound are described below.

Trial 1

The synthesis of BaF₂ was performed similarly to that for Ca₂NF with the furnace program as outlined in Chapter IV. The reactant mixture consisted of 1.660 g of barium metal powder and 0.707 g of BaF₂ in a 3:1 mole ratio of Ba:BaF₂. There were no single crystals mounted for this synthesis due to the fact that the resulting product was a gray powder with a layer of white powder substance. After observation, no single crystals were found to have been suitable for mounting.

Trial 2

This trial was performed with three different crucibles, with the first two crucibles set up for a different reaction than the third crucible. Crucibles A and B were prepared according to the following reaction: BaF₂ + Ba₃N₂ → 2Ba₂NF. Thus, this particular reaction utilized a direct synthesis method approach, as described in Chapter I. The third crucible contained reactants from the reaction: 3Ba + BaF₂ + N₂ → Ba₂NF. This triple synthesis used the following masses of reactants:

Crucible A: 0.451 g BaF₂, 1.156 g Ba₃N₂

Crucible B: 2.190 g BaF₂, 5.388 g Ba₃N₂

Crucible C: 0.757 g barium metal, 0.341 g BaF₂

The program as used in Trial 1 above was altered in Steps 2, 4 and 5. This is shown in the following program:

Step 1: R1: Step function; L1: 28°C; D1: 0.0 hours

Step 2: R2: 60°C/hour; L2: 900°C; D2: 1.0 hour

Step 3: R3: 60°C/hour; L3: 200°C; D3: 2.0 hours

Switched from Ar to N₂ gas at this point

Step 4: R4: 60°C/hour; L4: 900°C; D4: 15.0 hours

Step 5: R5: 15°C/hour; L5: 200°C; D5: 0.0 hours

Step 6: R6: 80°C/hour; L6: 28°C, D6: End of program

After inspection of the three crucibles, variations of black, white and gray color and powder/crystalline consistency were found in the crucibles. Crucible A had a thick layer of white on the surface with no other color showing. Crucible B displayed mostly white powder on the surface with small flakes of dark gray and black. And finally, crucible C had black and gray pieces with white powder-like specs on the surface and throughout the sample. Pink single crystals were also found in this crucible, but not in the other two crucibles. Several samples were mounted using Crystal Mounting Method 4, page 44, however, none of the lightly colored pink crystals that were mounted were protected enough from the glass cover to remain pink for more than a few hours.

Single Crystal X-ray Analysis of Ca₂NF

X-ray data were collected on a Bruker SMART 1k CCD Single Crystal Diffractometer System equipped with a fine focus, 3.0 kW sealed tube X-ray source (MoK α radiation, $\lambda = 0.71073 \text{ \AA}$) operating at 50 kV and 40 mA. Approximately 1.0 hemispheres of intensity data were collected in 1800 frames using ω scans (width of 0.30° and exposure time of 10 s per frame). Following data collection, initial attempts to reduce the cell indicated the possible presence of twinning in the sample. Bruker's GEMINI

program was then used in an attempt to assign orientation matrices to the twins, however the program could assign only one orientation matrix, using reflections thresholded from 450 of the total 1800 frames collected. As will be discussed in Chapter VI, it was later hypothesized that the sample is actually polycrystalline rather than twinned, with one larger predominant crystallite, and one or more smaller ones. In order to continue the structure analysis, this orientation matrix obtained from GEMINI based on part of the data was used in SMART to determine the higher symmetry cell (i.e. Bravais lattice), and to refine the unit cell parameters. The resulting refined cell was then used to integrate all data in SAINT, which used 384 reflections to achieve the final parameters that were used in the ensuing structural refinement. Prior to structure solution and refinement, an empirical absorption correction was performed on the data files written by SAINT using SADABS (written by George Sheldrick, University of Göttingen, 1996), which also simultaneously corrected for other effects, such as absorption by the glass capillary. Refinement data, including the cell parameters, are summarized in Table 5.1.

Structure Solution and Refinement

As the unit cell parameters indicated a tetragonal structure, it was immediately realized that the Ca_2NF sample prepared here is not isostructural with CaO (cubic rocksalt-type), as reported previously by Erlich.¹¹ The parameters are however similar to those for $\text{L-Mg}_2\text{NF}$ reported by Andersson,¹⁰ which are $a = 4.186$ and $c = 10.042 \text{ \AA}$. Also, XPREP for the Ca_2NF sample suggested a space group of $I4_1/\text{amd}$, which is the space group suggested by Andersson for Mg_2NF . Thus, it is apparent that the Ca_2NF prepared in

Table 5.1**Crystal Data Summary and Refinement Results for Ca₂NF**

Structural Formula	Ca ₂ NF
Formula Weight	113.17
Color	Yellow
Crystal Size (mm)	0.09 x 0.16 x 0.24
Space Group	I41/amd
a (Å)	4.9018(9)
b (Å)	4.9018(9)
c (Å)	10.516(3)
β (°)	101.246(13)
V (Å ³)	252.67(9)
Z	4
ρ _{calc} (Mg/m ³)	2.975
λ(CuKα) (Å)	1.54178
μ (mm ⁻¹)	4.197
θ Range for Data Collection (°)	4.59 to 28.24
Limiting Indices	-5 ≤ h ≤ 6, -6 ≤ k ≤ 6, -12 ≤ l ≤ 13
No. of Reflections Collected	695
No. of Independent Reflections	101 (R _{int} = 0.0894)
No. of Parameters	12
Refinement Method	Full-matrix least-squares on F ²
Final R Indices [I>2σ(I)]	R ₁ (F) ^a = 0.0316, wR ₂ (F ²) ^b = 0.0585
Final R Indices (All Data)	R ₁ (F) ^a = 0.0426, wR ₂ (F ²) ^b = 0.0630
Goodness-of-Fit on F ²	1.178
Largest Diff. Peak and Hole	0.604 and -0.422 eÅ ⁻³

^aR₁(F) = $\frac{\sum ||F_o| - |F_c||}{\sum |F_o|}$ with F_o > 4.0σ(F).
^bwR₂(F²) = $[\frac{\sum [w(F_o^2 - F_c^2)^2]}{\sum [w(F_o^2)^2]}]^{1/2}$ with F_o > 4.0σ(F), and w⁻¹ = σ²(F_o)² + (W·P)² + T·P, where P = (Max(F_o², 0) + 2F_c²)/3, W = 0.0272, and T = 0.00.

the project is isostructural with Andersson's L-Mg₂NF compound, and also with the Sr₂NF powder analyzed by Potkonicky.¹³

The structure was determined using Direct Methods and the three atomic positions expected (i.e. one calcium, one nitrogen, and one fluorine) by comparison to the L-Mg₂NF-type structure could be assigned immediately. Following the initial structure solution, the refinement converged after six cycles, as summarized in Table 5.2.

After the sixth refinement, the final structure was achieved by observing successful convergence of all atomic positions, displacement factors and occupancies. In general, acceptable convergence of the aforementioned parameters are at or below a shift of 0.1. In this refinement, the final shift was 0.0 for convergence, suggesting that all of the parameters were consistent and convergence was achieved.

The final atomic coordinates, occupancy factors and anisotropic and equivalent isotropic displacement parameters are listed in Table 5.3. From the occupancy factors, the composition was found to be Ca_{2.00}N_{1.09}F_{1.00}, in good agreement with the ideal composition of Ca₂NF. The displacement parameters listed in Table 5.3 are typical for inorganic solids.

Despite the fact that this structure determination is based on less than half of the total data collected, the data/parameter ratio of 8.4 (see Table 5.1) indicates that there was sufficient data to achieve a conclusive refinement. The R values obtained for the refinement were fairly low, and are typical for inorganic structures refined from a complete data set. This indicated that intensity contributions from other crystallites presumably present did not introduce significant error. The structure refinement is also

Table 5.2**Refinements for Ca₂NF**

<u>Refinement #</u>	<u>Merging R Value</u>	<u>Description of Refinement</u>
1	0.0391	Assigned all atoms (Ca1, N1, F1)
2	0.0312	Refined anisotropic displacement parameters for all three atom positions
3	0.0312	Refined extinction
4	0.0312	ACTA entered to save all required data in crystallographic information file
5	0.0312	Refined occupancy factors for all three atom positions
6	0.0316	Weight changed to refine any additional crystallographic parameters

Table 5.3

**Positional, Occupational, and Anisotropic^a and Equivalent
Isotropic^b Displacement Parameters ($\text{\AA}^2 \times 10^4$) From Ca₂NF Final Refinement**

Atom	Ca(1)	F(1)	N(1)
Site	8e	4a	4b
Occupancy Factors	0.24988	0.13630	0.12453
X	1/2	0	1/2
Y	3/4	3/4	1/4
Z	0.032(1)	0.125	0.125
U ₁₁	12(1)	14(2)	16(2)
U ₂₂	10(1)	14(2)	16(2)
U ₃₃	12(1)	40(4)	12(4)
U ₁₂	0	0	0
U ₁₃	0	0	0
U ₂₃	0	0	0
U _(eq)	11(1)	22(2)	15(2)

^aThe anisotropic thermal parameter is expressed as $\exp[-2\pi^2(h^2a^{*2}U_{11} + k^2b^{*2}U_{22} + l^2c^{*2}U_{33} + 2hka^*b^*U_{12} + 2hla^*c^*U_{13} + 2klb^*c^*U_{23})]$.

^bU_(eq) is defined as one third of the trace of the U_{ij} orthogonalized tensor.

acceptable based upon the previously reported L-Mg₂NF structure, i.e. it makes “chemical sense.” Based on these factors, the overall refinement is deemed to be quite successful. It should be noted that this is apparently the first single crystal structure refinement of an inorganic nitride-fluoride compound ever reported.

CHAPTER VI

DISCUSSION

Introduction

The main focus of this chapter concerns the crystal chemistry of the Ca_2NF structure described in Chapter V. In addition, the partial polycrystalline nature of the sample used in the structure analysis will be discussed. The chapter will conclude with a discussion of possible future directions for this work as well as related research.

Polycrystallinity of the Ca_2NF Sample

As mentioned in the last chapter, the single crystal structure refinement of the successfully mounted Ca_2NF sample was based on only a partial data set. This is because the data set in its entirety could not be indexed using a common orientation matrix, and GEMINI could not find a twin law relating the indexed data to the rest of the data set. Attempts to index the rest of the data set by first deleting the successfully indexed data also failed. This led to the hypothesis that the Ca_2NF sample was not actually single crystalline, but rather polycrystalline, consisting of one large crystal (from which the structure was successfully obtained) and several smaller ones. Since the crystal was very small (which was generally the case for the hundreds of crystals observed), the presence of the small crystallites could have easily escaped detection during mounting. It is also quite possible that the crystal fractured while being inserted in the capillary tube.

To test the hypothesis of a polycrystalline sample, the 450 frames of data used for the structure refinement, containing both indexed and unindexed reflections, were analyzed as powder diffraction data. The reasoning here is that analysis of powder diffraction data does not require knowledge of the specific orientations of the crystallites, and does not even require a single-phase sample. To accomplish this analysis, the 450 frames of data were unwarped on the system at Kent State University (i.e. where the data was collected) and then imported into the GADDS system (i.e. for powder analysis) on-site at YSU. Before integrating the data in the GADDS system, it was first necessary to calibrate GADDS for analysis of data from a CCD detector, since GADDS is normally configured for the multi-wire detector available on site. The calibration was performed by collecting corundum powder data on the Kent State University CCD system, unwarping the data, and then importing it into the GADDS system for adjustment of the x and y center and detector distance parameters. Following the calibration, all 450 frames of Ca_2NF single crystal data obtained from the Kent State University CCD system were integrated (from 3.0 to 175.1° in χ) in GADDS, and merged into a single diffraction pattern. The resulting diffraction pattern, after background subtraction, is shown in Figure 6.1 and spans a 2θ range of 13 to 56° .

After the diffraction pattern was obtained, the "powder" data was indexed using the TREOR program on Bruker's WIN-INDEX package (version 1.5), and cell parameters were refined using WIN-METRIC (version 2.1). The final cell parameters obtained from the powder pattern analysis were: $a = 4.88259(321) \text{ \AA}$ and $c = 10.4674(1468) \text{ \AA}$. These compare fairly closely to the parameters used for the single crystal structure refinement,

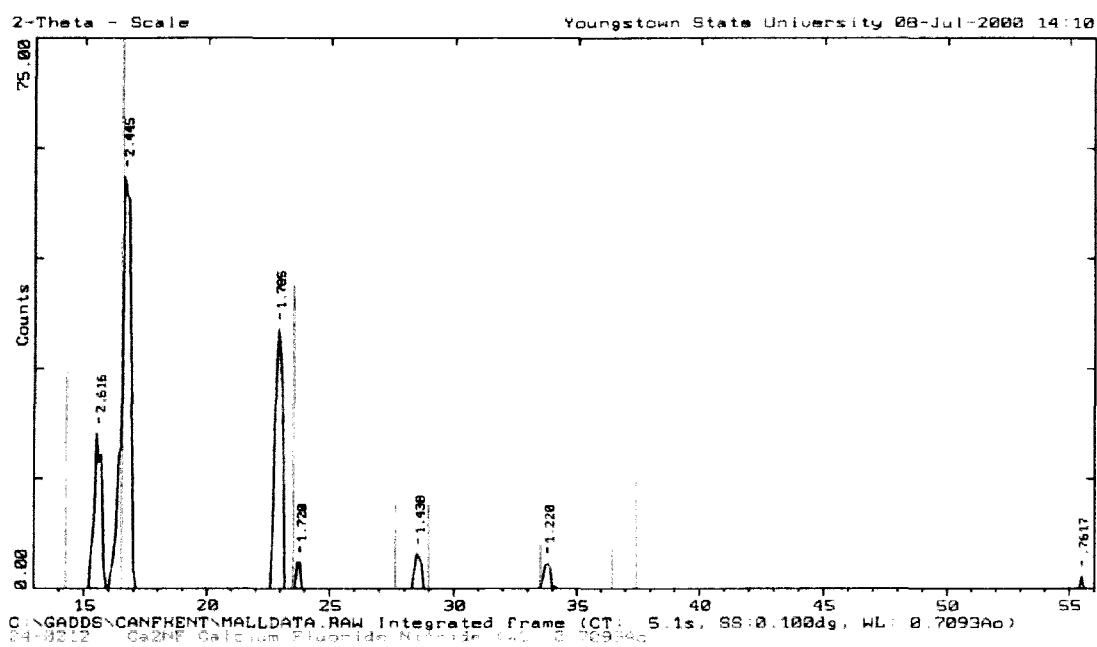

Figure 6.1 Equivalent powder X-ray diffraction pattern for Ca_2NF obtained after merging 450 frames of single crystal data in GADDS.

viz. $a = 4.9018(9) \text{ \AA}$ and $c = 10.516(3) \text{ \AA}$. A closer match cannot be expected based on the fact that so few reflections are present on the powder pattern. This in turn is likely due to the fact that GADDS could not integrate many of the isolated weak reflection points that were present, since GADDS is designed to integrate powder rings and not spots. It should be noted here that partial powder rings were frequently observed during the GADDS integration, suggesting that the Ca_2NF sample was indeed powder-like. Table 6.1 summarizes the powder analysis data. The fact that all the reflections could be indexed using the same cell parameters indicates that the Ca_2NF sample was a single phase material, and did not decompose during the data collection. We are not aware of any other successful "single crystal" structure analysis of a polycrystalline sample.

Single Crystal Structure Analysis of Ca_2NF

Based on the crystallographic information presented in Chapter V, it was concluded that the Ca_2NF compound reported here is not isostructural with that reported by Erlich,¹¹ et al. as having the rocksalt type structure. This is clearly illustrated by the powder diffraction pattern in Figure 6.1, which compares the present experimental data to Erlich et al.'s data stored in the database. The cubic cell edge for Ca_2NF reported in the Erlich paper is 4.937 \AA , which is somewhat larger than the a and c cell edges for the present sample. Possible explanations for the discrepancy are that the cubic cell parameters are based on relatively few powder reflections and/or poor data, or that a phase different from the present one was actually synthesized. For example, Erlich

Table 6.1**Comparison of Equivalent Powder d-Spacings from Ca₂NF Single Crystal Data to Calculated d-Spacings**

<u>(hkl)</u>	<u>d_(obs)</u>	<u>d*_(calc)</u>	<u> d_{obs}-d_{calc} </u>
(004)	2.6165	2.6168	0.0003
(200)	2.4446	2.4413	0.0033
(204)	1.7853	1.7851	0.0002
(220)	1.7199	1.7263	0.0064
(224)	1.4380	1.4410	0.0030
(440)	1.2202	1.2206	0.0004
(540)	0.7617	0.7625	0.0008

*based on cell parameters obtained from Bruker's WIN-METRIC package, ver 2.1:
a=4.88259 and c = 10.4674 Å

et al. could have actually synthesized a Ca_3NF_3 phase, isostructural with Andersson's¹⁰ cubic Mg_3NF_3 compound.

The reason that Ca_2NF does not have the rocksalt structure (at least at ambient pressure) is likely due to the fact that calcium would be overbonded in octahedral coordination with three N^{3-} ions and three F^- ions. Likewise, one would expect calcium in tetrahedral coordination (as in the ZnS structure) to two N^{3-} ions and two F^- ions to be underbonded. This was discussed in detail for the case of Sr_2NF by Potkonicky.¹³ The optimal structure is the one originally proposed by Andersson¹⁰ for L- Mg_2NF , in which magnesium is basically five-coordinated to three N^{3-} ions and two F^- ions, with a sixth longer bond to a F^- ion. The single crystal analysis completed in this study unambiguously assigns a L- Mg_2NF -type structure to Ca_2NF , and the resulting structure plot is shown in Figure 6.2.

Bond-Valence Sum Method and Analysis Results

To verify the overall structure of Ca_2NF , the empirical bond-valence sum analysis is performed. This method involves calculating the individual bond valences with respect to a specific bonded pair of atoms, such as Ca-N, and then summing the total valences around an atom of interest, like calcium. If the bond-valence sum is equal to the ideal oxidation state of the specified atom (again, calcium for this case) then the crystallographic structure is considered acceptable. As described by Brese and O'Keeffe,²¹ the bond valence, v_{ij} , is between two atoms i and j , and the sum of all of the valences are given by the following:

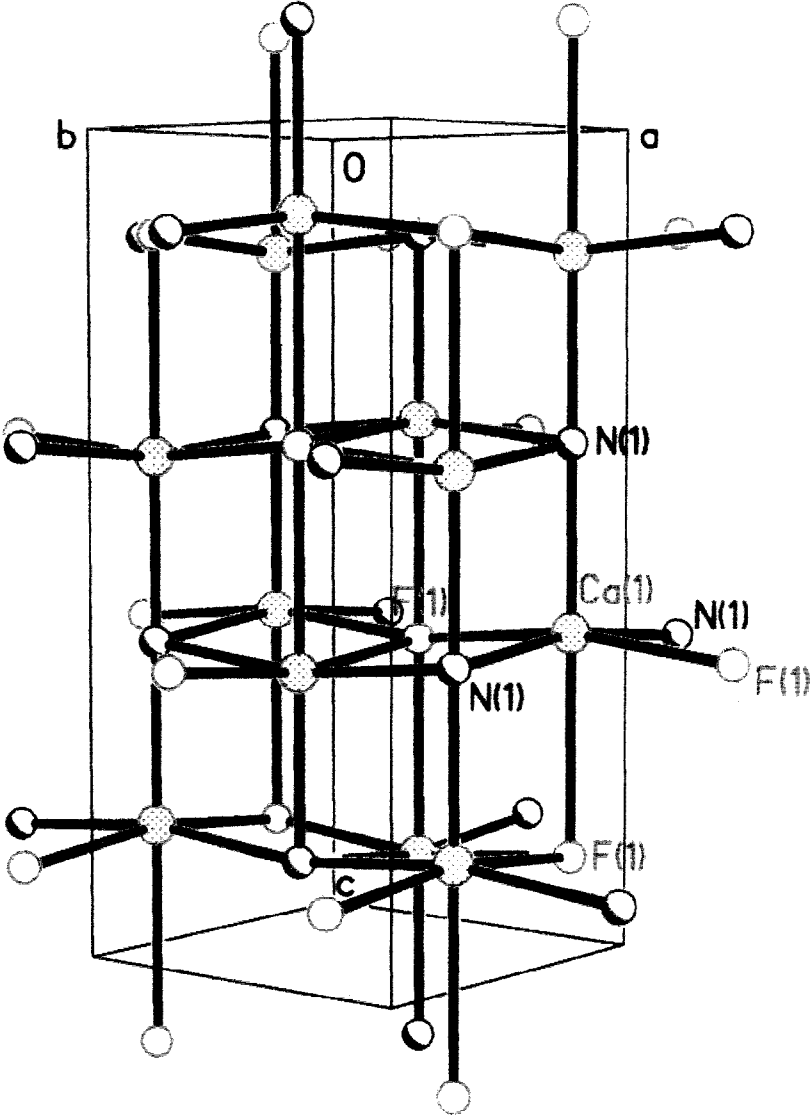

Figure 6.2 Ball and Stick Plot for Ca_2NF .

$$\sum_j v_{ij} = V_i,$$

where v_{ij} is equal to the equation given below:

$$v_{ij} = \exp [(R_{ij} - d_{ij})/b].$$

In the above expression, b is referred to as a universal constant of 0.37 Å. R_{ij} is a unitless empirical parameter that represents the bonds between pairs of atoms in a structure, i.e. the bond valence parameter. And finally, d_{ij} is the experimental bond length. The R_{ij} values were obtained for Ca-N and Ca-F from the paper by Brese and O'Keeffe: for Ca-N, $R_{ij} = 2.14$ and for Ca-F, $R_{ij} = 1.824$. The bond valence sum results for Ca_2NF are summarized in Table 6.2.

Using the calcium atom as the central atom for the above calculations, it would be expected that the calculated valence sum should be close to 2.0, which is the ideal valence for the calcium atom. However, the results in Table 6.2 indicate that the bond valence sum of 1.771 obtained here is lower than 2.0 by about 11.5%. According to Brese and O'Keeffe,²¹ some error (from 2 to 14% or higher) in the bond valence sum calculation is expected, depending on the quality of the structural data used to derive the empirical parameters used in the equation given above. Another point worth making regarding the Ca-N and Ca-F parameters used in this calculation is that these were derived mainly from nitride and fluoride compounds, respectively. It is likely that few polycompounds (i.e. compounds containing two types of anions, such as fluorine and oxygen), and certainly no nitride-fluoride structures, were used to derive them. Thus, subtle crystal chemical factors, such as N-F nonbonded interactions that may be present in Ca_2NF , would not be

Table 6.2**Bond Valence Sum Results for Ca₂NF**

<u>Bond</u>	<u>Bond Distance</u>	<u>Bond Valence</u>
Ca-N1	2.4000 Å	0.495
Ca-N2	2.4616 Å	0.419
Ca-N3	2.4616 Å	0.419
Ca-F1	2.4616 Å	0.187
Ca-F2	2.4616 Å	0.187
Ca-F3	2.8579 Å	0.064
<hr/>		
$V_i(\text{Ca}) = \sum v_{ij}$		1.771

inherent in the empirical database parameters used in the calculation. Based on this discussion, it can be concluded that the bond valence sum results obtained here are compatible with the proposed structure.

Future Research Related to Nitride-Fluoride Analogs

The most obvious area for future work is to apply the synthesis and X-ray sample mounting techniques developed in this thesis for Ca_2NF to other nitride-fluoride analogs of binary oxides. Examples for possible single crystal preparation and analysis include Sr_2NF , Ba_2NF , Mg_2NF , TiNF , Ni_2NF , $\text{Y}_2(\text{NF})_{1.5}$, and Cu_2NF . Although rigorous structural analysis based on powder X-ray diffraction has been published for two of the compounds listed (viz. Mg_2NF and TiNF), no quantitative single crystal studies have been reported for any of them.

While single crystal X-ray diffraction is widely recognized as the best method available for elucidating crystal structures, the technique provides only an average structure over many unit cells. This is sufficient for the majority of samples analyzed, which are well ordered. For compounds with superlattice ordering present, such as might be the case in nitride-fluorides, other techniques are required to characterize the nature of any ordering present. In the case of nitride-fluoride compounds, the method of choice for determining whether or not there is ordering of nitrogen and fluorine atoms in the lattice is neutron powder diffraction. This is because the scattering factors for nitrogen and fluorine are quite different for neutron diffraction, whereas they are very similar in X-ray diffraction, making it difficult to differentiate between the two atoms by this method.

Therefore, it would be quite worthwhile to complement single crystal X-ray diffraction studies of the nitride-fluorides prepared with powder neutron diffraction.

Another possibility for future work involves preparation of nitride-fluoride analogs of ternary oxides such as perovskite, CaTiO_3 . These would be prepared by first making nitride-fluoride precursors, and then reacting them using standard ceramic methods. For example, a perovskite analog could be made according to the following reaction: $\frac{1}{2} \text{Ca}_2\text{NF} + \text{TiNF} \rightarrow \text{CaTi}(\text{NF})_{1.5}$. Successful preparation of this product would be significant, since no ternary nitride-fluoride analogs have yet been reported. Also, perovskites in general have become widely studied in recent years due to their relationship to high temperature superconducting oxides. A related goal for the long term would be to attempt preparation of more complex nitride-fluoride compounds such as $\text{YBa}_2\text{Cu}_3(\text{NF})_{3.25}$, which is an analog of the so-called 1-2-3 high temperature superconducting oxide, $\text{YBa}_2\text{Cu}_3\text{O}_{6.5}$. The successful preparation of this phase would be significant in terms of comparison of its properties to those of the oxide material.

As so few inorganic nitride-fluoride compounds have been prepared and studied to date, possibilities for research in this field are essentially unlimited.

CHAPTER VII

SINGLE CRYSTAL ANALYSIS OF α -OXY- β -SUBSTITUTED- β -AMINO ESTERS

Introduction

This chapter describes the results of single crystal X-ray diffraction studies of three organic samples provided by James C. Adrian Jr., Assistant Professor of Chemistry, Science and Engineering Center, Union College, Schenectady, New York. Before describing the X-ray diffraction analysis, a brief background related to the samples is given below.

Background of Organic Structure and Synthesis

With respect to β -amino acids, they are found less than α -amino acids, yet they do contribute significantly to the field of pharmacology.²² The difference between α and β -amino acids is the location of the amino group in relation to the carboxylic acid group. α -amino acids have an amino and a carboxylic acid group both bonded to a central carbon atom, i.e. the α -carbon. β -amino acids have an amino group attached to a carbon atom that is located two carbons away (β -carbon) from the carboxylic acid attachment site. β -amino acids are known to serve as precursors or synthetic intermediates, in the preparation of the class known as β -lactam antibiotics.²³ It has also been discovered that

the peptides of the β -amino acids have the ability to construct folding patterns that are close in structure to that for α -amino acid peptides.^{24,25} Due to these factors, β -amino acids are an intriguing category related to pharmacology, of which single step methods for the stereoselective preparations of α -oxy- β -substituted β -amino acids will be explored.^{26,27}

Synthetically, the phenylisoserine derivatives are of great interest to organic chemists, because of the fact that their β -amino ester side chain is related to that of Taxol. The interest in this synthesis stems from a stereoselectivity that could occur in one step. To prepare this there are two methods that are utilized. The first is that of a direct coupling of the C₂-C₃ bonds. This differs from the second method which uses a functional transforming of the C₂-C₃ bonds. Another direct coupling method is the use of chlorotitanium enolates added to aldimines, an overlooked type of single step synthesis.

Two different research groups; Mukai, Kim and Hanaoka and Annunziata,²⁸ et al. performed and published separate work in this subject in 1992. They both reported that α,β -dihydroxy thioesters were synthesized in high yields after an aldol reaction occurred from chlorotitanium enolates and O-protected aryl thioglycolates. Both research groups found that the Aldol reactions that occurred had produced the anti isomer. Later, Cozzi,²⁹ et al. proved that the stereoselectivity of the anti versus syn reaction was related to the protecting group utilized. This was found to have been dependent upon the size of the O-protecting group, i.e. a small benzyl group produced an anti isomer, while a sterically bulky (TBDMS) group created a syn isomer. The research that was conducted by James C. Adrian and analyzed via X-ray diffraction methods in this section of the thesis

demonstrates that via an addition of enolates of methyl methoxyacetate to aldimines, an α -oxy- β -substituted- β -amino ester results with a higher yield for the anti isomer relative to the syn isomer. The reaction scheme is shown in Figure 7.1

Imine substitution of the β -amino ester was the method of synthesis utilized by James C. Adrian to produce the anti isomer. Enolization of methyl methoxyacetate occurred with TiCl_4 and diisopropylethylamine (DIPEA) at -80°C in CH_2Cl_2 . The violate enolate was placed into 0.5 molar equivalents of the imine into CH_2Cl_2 at -80°C again. Significant β -amino esters resulted. HPLC was used to determine the anti to syn ratio of the product. 200-MHz NMR was another method used for determining which diastereomer was produced. The major product of *para*-chlorophenyl, which was the ester methyl 3-(2-methoxyphenyl)amino-2-methoxy-3-(4-chloro)phenylpropionate (**1**), was found to have been the anti isomer. **1** was grown in a 95% ethanol solvent. The method of determining this was via single crystal X-ray diffraction, as performed in this study. It was also found in the same method that the minor product of phenyl was the ester methyl 3-(2-methoxyphenyl)amino-2-methoxy-3-phenylpropanoate (**2**, **3**) was found to have been the syn isomer. **2** and **3** have the same relative stereochemistry, but their solvents were varied. **2** was crystallized in a 95% ethanol solution, while **3** was crystallized in isopropyl alcohol. To explicitly explain the HPLC and NMR results, as well as the working hypothesis for why the anti is the more abundant isomer as aforementioned is beyond the intentions of this thesis, but see the paper "Chlorotitanium Enolate Addition to Aldimines: A Stereoselective Route to α -Oxy- β -Substituted- β -

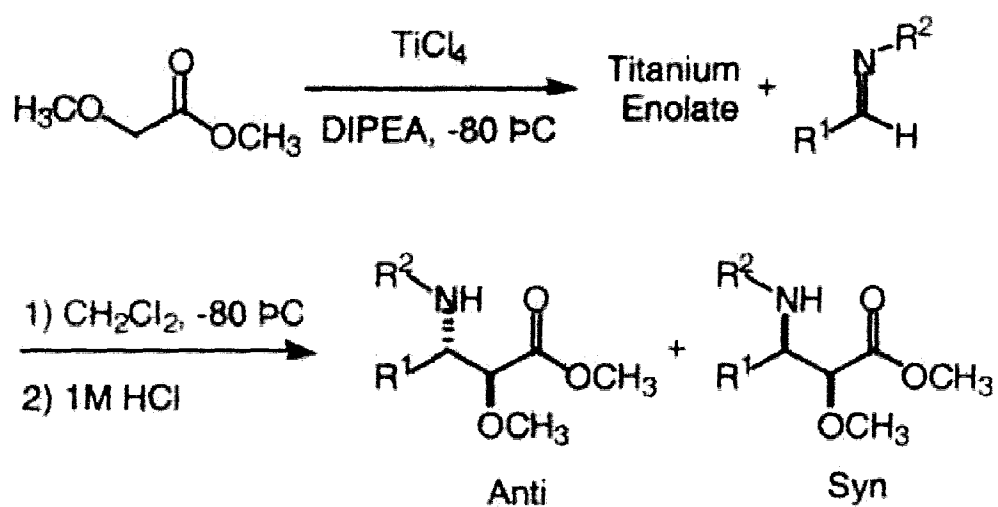

Figure 7.1 The reaction pathway for the α -oxy- β -substituted- β -amino ester.

Amino Esters,” by Adrian,³⁰ et al. However, the determination of structure of **1**, **2** and **3** via X-ray diffraction methods will be discussed next.

X-Ray Diffraction Analysis of Organic Compounds

Three crystals were found and selected via a stereo-microscope and were then mounted onto a thin piece of glass fiber with clear epoxy glue. The crystal was then centered optically into the X-ray beam of a Bruker P4 automated diffractometer, equipped with a normal focus, 2.4 Kw copper sealed tube. Rotation photographs and peak profiles of representative reflections were used to evaluate crystal quality. The data collection results and solution parameters are summarized in Tables 7.1, 7.2 and 7.3.

Data was collected via Bruker’s XSCANS software package. The preliminary unit cell was found from centering the reflections chosen from the rotation photograph previously taken. Axial photographs, a fractional search, and a thin shell search then followed. These aided in the centering of 100 reflections for finding the final unit cell parameters of **1**, **2** and **3**. Bravais and Laue symmetry determinations were then performed. Three of the strong and orthogonal reflections from the thin shell were chosen as check reflections as standards for the analysis and were recollected after each 97 data reflections.

The structure solution was determined via the SHELXTL package for Windows NT from Bruker on a Gateway 2000 Pentium and/or Pentium Pro computer. Data was corrected for Lorentz and polarization effects and also for absorption using the empirical Psi-scan data. The refinements were carried out on F^2 for all data. Structure solution

Table 7.1**Crystal Data Summary and Refinement Results for 1**

Structural Formula	C ₁₇ H ₁₉ NO
Formula Weight	253.33
Color	Colorless
Crystal Size (mm)	0.12 x 0.36 x 0.14
Space Group	P2 ₁ /c
a (Å)	10.7610(3)
b (Å)	16.0943(4)
c (Å)	8.9848(4)
β (°)	100.378(3)
V (Å ³)	1530.63(9)
Z	4
ρ _{calc} (Mg/m ³)	1.099
λ(CuKα) (Å)	1.54178
μ (mm ⁻¹)	0.527
θ Range for Data Collection (°)	4.18 to 56.75
Limiting Indices	-11 ≤ h ≤ 11, -17 ≤ k ≤ 17, -9 ≤ l ≤ 9
No. of Reflections Collected	4228
No. of Independent Reflections	2008 (R _{int} = 0.0461)
No. of Parameters	267
Refinement Method	Full-matrix least-squares on F ²
Final R Indices [I > 2σ(I)]	R ₁ (F) ^a = 0.0377, wR ₂ (F ²) ^b = 0.1048
Final R Indices (All Data)	R ₁ (F) ^a = 0.0470, wR ₂ (F ²) ^b = 0.1198
Goodness-of-Fit on F ²	0.992
Extinction Coefficient	0.0080(9)
Largest Diff. Peak and Hole	0.156 and -0.147 eÅ ⁻³

$$^a R_1(F) = \frac{\sum ||F_o| - |F_c||}{\sum |F_o|} \text{ with } F_o > 4.0\sigma(F).$$

$$^b wR_2(F^2) = \frac{[\sum [w(F_o^2 - F_c^2)^2] / \sum [w(F_o^2)^2]]^{1/2}}{\sigma^2(F_o^2) + (W \cdot P)^2 + T \cdot P}, \text{ where } P = (\text{Max}(F_o^2, 0) + 2F_c^2) / 3, W = 0.0718, \text{ and } T = 0.25.$$

Table 7.2**Crystal Data Summary and Refinement Results for 2**

Structural Formula	C ₁₈ H ₂₀ ClNO ₄
Formula Weight	349.80
Color	Colorless
Crystal Size (mm)	0.48 x 0.18 x 0.10
Space Group	Pna2(1)
a (Å)	11.6544(8)
b (Å)	19.5883(13)
c (Å)	7.9495(5)
V (Å ³)	1814.8(2)
Z	4
ρ _{calc} (Mg/m ³)	1.281
λ(CuKα) (Å)	1.54178
μ (mm ⁻¹)	2.041
θ Range for Data Collection (°)	4.41 to 57.19
Limiting Indices	-12 ≤ h ≤ 12, -21 ≤ k ≤ 21, -8 ≤ l ≤ 8
No. of Reflections Collected	2497
No. of Independent Reflections	2267 (R _{int} = 0.0243)
No. of Parameters	270
Refinement Method	Full-matrix least squares on F ²
Final R Indices [I > 2σ(I)]	R ₁ (F) ^a = 0.0408, wR ₂ (F ²) ^b = 0.1098
Final R Indices (All Data)	R ₁ (F) ^a = 0.0440, wR ₂ (F ²) ^b = 0.1146
Goodness-of-Fit on F ²	1.037
Absolute Structure Parameter	-0.01(3)
Extinction Coefficient	0.0065(7)
Largest Diff. Peak and Hole	0.222 and -0.205 eÅ ⁻³

^aR₁(F) = $\sum ||F_o| - |F_c|| / \sum |F_o|$ with F_o > 4.0σ(F).

^bwR₂(F²) = $[\sum [w(F_o^2 - F_c^2)^2] / \sum [w(F_o^2)^2]]^{1/2}$ with F_o > 4.0σ(F), and w⁻¹ = σ²(F_o)² + (W·P)² + T·P, where P = (Max(F_o², 0) + 2F_c²)/3, W = 0.0753, and T = 0.34.

Table 7.3**Crystal Data Summary and Refinement Results for 3**

Structural Formula	C ₁₈ H ₂₀ CINO ₄
Formula Weight	349.80
Color	Colorless
Crystal Size (mm)	0.26 x 0.08 x 0.10
Space Group	Pna2(1)
a (Å)	11.6442(11)
b (Å)	19.598(2)
c (Å)	7.9495(5)
V (Å ³)	1813.3(3)
Z	4
ρ _{calc} (Mg/m ³)	1.281
λ(CuKα) (Å)	1.54178
μ (mm ⁻¹)	2,043
θ Range for Data Collection (°)	4.42 to 56.71
Limiting Indices	-12 ≤ h ≤ 12, -21 ≤ k ≤ 21, -8 ≤ l ≤ 8
No. of Reflections Collected	2456
No. of Independent Reflections	2249 (R _{int} = 0.0267)
No. of Parameters	270
Refinement Method	Full-matrix least squares on F ²
Final R Indices [I > 2σ(I)]	R ₁ (F) ^a = 0.0473, wR ₂ (F ²) ^b = 0.1097
Final R Indices (All Data)	R ₁ (F) ^a = 0.0850, wR ₂ (F ²) ^b = 0.1433
Goodness-of-Fit on F ²	1.003
Absolute Structure Parameter	-0.02(4)
Extinction Coefficient	0.0021(4)
Largest Diff. Peak and Hole	0.228 and -0.166 eÅ ⁻³

^aR₁(F) = Σ ||F_o - F_c|| / Σ |F_o| with F_o > 4.0σ(F).

^bwR₂(F²) = [Σ[w(F_o² - F_c²)²] / Σ[w(F_o²)]^{1/2} with F_o > 4.0σ(F), and w⁻¹ = σ²(F_o)² + (W·P)² + T·P, where P = (Max(F_o², 0) + 2F_c²)/3, W = 0.0641, and T = 0.92.

proceeded in a routine fashion for all three compounds utilizing the SHELXS structure solution packages included in SHELXTL, version 5.05. All atomic scattering factors were taken by SHELXTL from the International Tables, Volume C. The initial solution was obtained from Direct Methods located from electron density difference maps and were refined first with isotropic displacement parameters and then with anisotropic displacement parameters. All hydrogen atoms were also located from electron density difference maps and were then refined isotropically. Extinction was refined in later refinement cycles and the weighting scheme used was that suggested by SHELXTL-XL. Molecular graphics and tabular data were generated with SHELXTL-XP and SHELXTL-XCIF. ORTEP-type structure plots for each of the three compounds are shown in Figures 7.2, 7.3 and 7.4.

Final fractional atomic coordinates for all three crystals and equivalent isotropic displacement parameters are listed in Tables 7.4, 7.5 and 7.6. Complete Tables of bond lengths and angles, hydrogen atom coordinates, tables of anisotropic displacement factors, and structure factor tables for all three samples are given in Appendices B, C and D.

Results of Single Crystal X-Ray Diffraction

The 50% ellipsoid plots shown in Figures 7.2, 7.3 and 7.4, as well as the bond distances and angles (see Appendices B, C and D) for **1**, **2** and **3** are typical for these types of compounds. Final X-ray diffraction results were found from the above plots to have proven that **1** was anti in structure, while **2** and **3** were both syn in structure. This

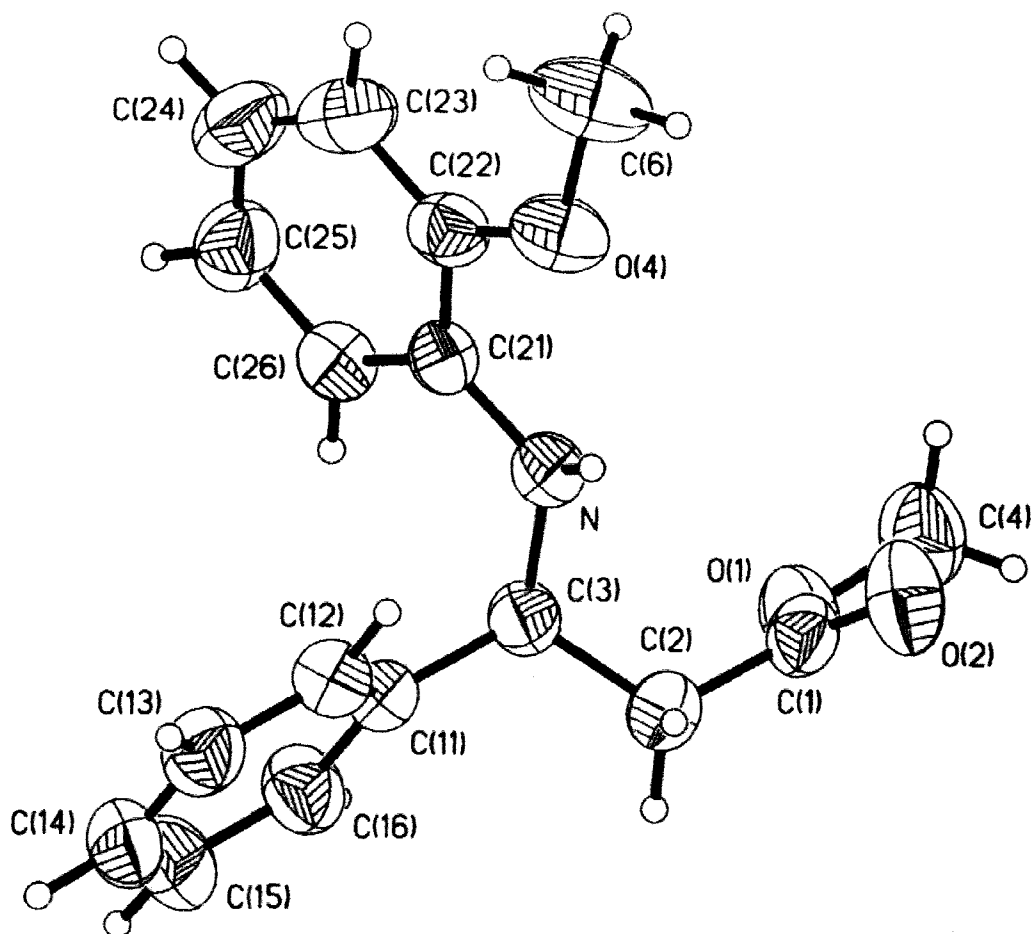

Figure 7.2 ORTEP-type plot (50% ellipsoids) for 1.

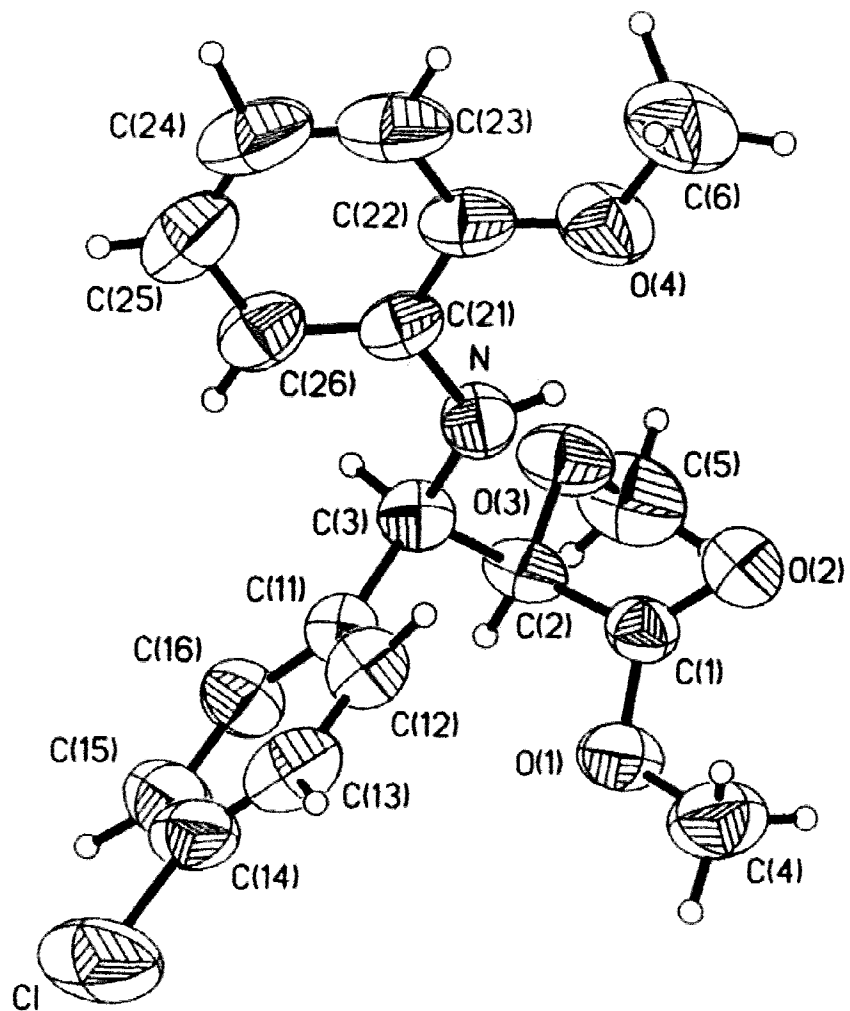

Figure 7.3 ORTEP-type plot (50% ellipsoid) for 2.

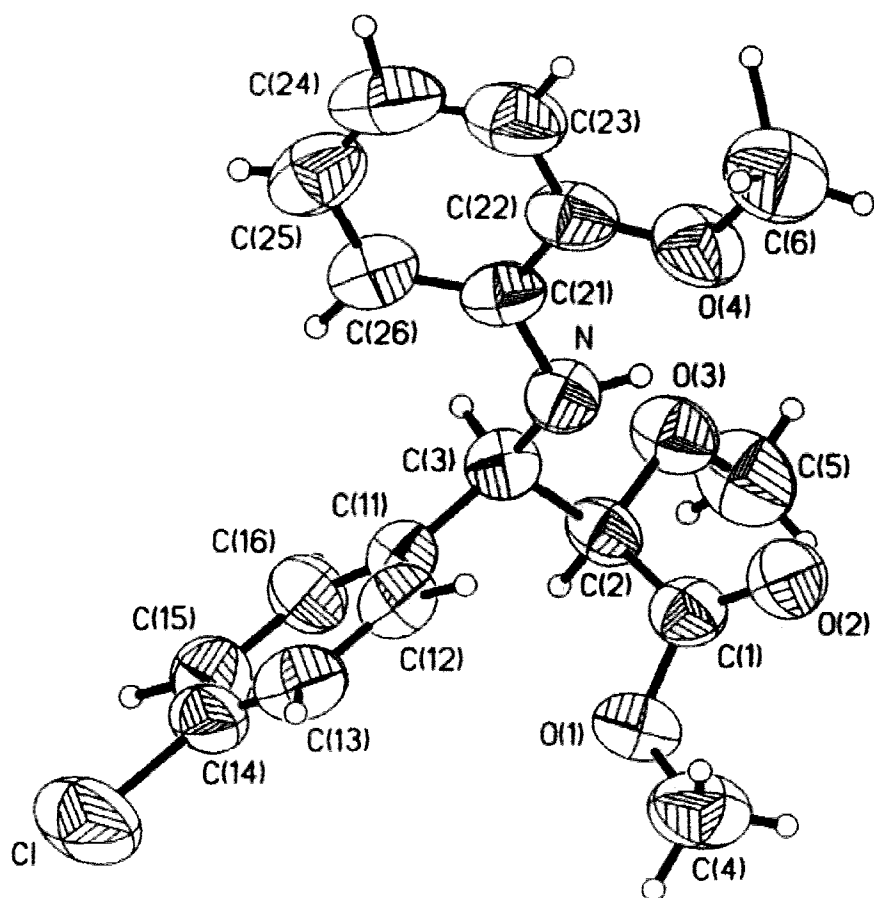

Figure 7.4 ORTEP-type plot (50% ellipsoids) for 3.

Table 7.4

Atomic coordinates [$\times 10^4$] and equivalent isotropic displacement parameters [$\text{\AA}^2 \times 10^3$] for 1. $U(\text{eq})$ is defined as one third of the trace of the orthogonalized U_{ij} tensor.

	x	y	z	$U(\text{eq})$
N	2866 (2)	5585 (1)	1186 (2)	51 (1)
O (1)	1890 (1)	4937 (1)	-2309 (2)	66 (1)
C (1)	3072 (2)	4837 (1)	-1591 (2)	52 (1)
O (2)	3967 (2)	5120 (1)	-2031 (2)	77 (1)
C (2)	3132 (2)	4331 (1)	-181 (2)	54 (1)
C (3)	2392 (2)	4745 (1)	924 (2)	48 (1)
O (4)	4161 (1)	6905 (1)	2233 (2)	66 (1)
C (4)	1679 (3)	5455 (2)	-3641 (3)	77 (1)
C (6)	4804 (3)	7674 (2)	2507 (5)	91 (1)
C (11)	2444 (2)	4225 (1)	2345 (2)	47 (1)
C (12)	3430 (2)	4298 (1)	3557 (2)	54 (1)
C (13)	3462 (2)	3813 (1)	4841 (2)	64 (1)
C (14)	2509 (2)	3254 (2)	4915 (3)	69 (1)
C (15)	1535 (3)	3172 (2)	3716 (3)	73 (1)
C (16)	1502 (2)	3654 (1)	2446 (3)	63 (1)
C (21)	2313 (2)	6131 (1)	2074 (2)	47 (1)
C (22)	2991 (2)	6844 (1)	2633 (2)	52 (1)
C (23)	2491 (2)	7406 (2)	3522 (3)	69 (1)
C (24)	1298 (3)	7276 (2)	3845 (3)	75 (1)
C (25)	606 (2)	6597 (2)	3275 (2)	68 (1)
C (26)	1111 (2)	6028 (1)	2401 (2)	56 (1)

Table 7.5

Atomic coordinates [$\times 10^4$] and equivalent isotropic displacement parameters [$\text{\AA}^2 \times 10^3$] for 2. $U(\text{eq})$ is defined as one third of the trace of the orthogonalized U_{ij} tensor.

	x	y	z	$U(\text{eq})$
Cl	6799 (1)	4299 (1)	1430 (2)	130 (1)
N	6843 (2)	1395 (1)	5989 (4)	59 (1)
O (1)	8551 (2)	1396 (1)	2068 (3)	66 (1)
C (1)	8451 (2)	1022 (1)	3449 (5)	54 (1)
O (2)	8093 (2)	446 (1)	3460 (3)	77 (1)
C (2)	8825 (3)	1410 (2)	5001 (4)	54 (1)
O (3)	9160 (2)	970 (1)	6301 (3)	69 (1)
C (3)	7820 (2)	1836 (2)	5707 (4)	53 (1)
O (4)	5370 (2)	453 (1)	6917 (4)	86 (1)
C (4)	8097 (4)	1110 (2)	521 (5)	90 (1)
C (5)	10279 (3)	702 (2)	6075 (6)	92 (1)
C (6)	4560 (5)	-72 (3)	7245 (9)	112 (2)
C (11)	7541 (2)	2440 (1)	4591 (4)	51 (1)
C (12)	8228 (3)	3010 (2)	4660 (5)	65 (1)
C (13)	8019 (4)	3580 (2)	3693 (6)	81 (1)
C (14)	7090 (4)	3581 (2)	2628 (5)	75 (1)
C (15)	6406 (4)	3023 (2)	2518 (5)	79 (1)
C (16)	6624 (3)	2451 (2)	3477 (5)	63 (1)
C (21)	5989 (2)	1582 (2)	7111 (4)	58 (1)
C (22)	5182 (3)	1086 (2)	7588 (4)	68 (1)
C (23)	4279 (3)	1254 (3)	8649 (6)	92 (1)
C (24)	4174 (4)	1918 (3)	9235 (6)	99 (2)
C (25)	4937 (4)	2401 (3)	8773 (5)	87 (1)
C (26)	5864 (3)	2241 (2)	7730 (5)	68 (1)

Table 7.6

Atomic coordinates [$\times 10^4$] and equivalent isotropic displacement parameters [$\text{\AA}^2 \times 10^3$] for 3. $U(\text{eq})$ is defined as one third of the trace of the orthogonalized U_{ij} tensor.

	x	y	z	$U(\text{eq})$
C1	-1792 (2)	-5705 (1)	-3504 (3)	136 (1)
N	-1848 (4)	-8604 (3)	-8051 (6)	64 (1)
O (1)	-3549 (3)	-8605 (2)	-4138 (5)	74 (1)
C (1)	-3456 (5)	-8983 (3)	-5530 (9)	62 (1)
C (2)	-3832 (5)	-8587 (3)	-7074 (7)	58 (2)
O (2)	-3086 (4)	-9555 (2)	-5522 (6)	84 (1)
O (3)	-4160 (3)	-9030 (2)	-8379 (5)	75 (1)
C (3)	-2820 (4)	-8164 (3)	-7771 (8)	59 (2)
O (4)	-369 (4)	-9541 (2)	-8992 (6)	88 (1)
C (4)	-3094 (6)	-8888 (4)	-2584 (9)	97 (2)
C (5)	-5281 (5)	-9300 (4)	-8154 (10)	100 (2)
C (6)	442 (9)	-10067 (6)	-9335 (15)	111 (3)
C (11)	-2539 (4)	-7562 (3)	-6647 (7)	54 (1)
C (12)	-1621 (5)	-7554 (3)	-5564 (8)	64 (2)
C (13)	-1407 (6)	-6980 (4)	-4598 (9)	80 (2)
C (14)	-2090 (7)	-6422 (4)	-4720 (9)	81 (2)
C (15)	-3019 (6)	-6418 (4)	-5760 (10)	83 (2)
C (16)	-3226 (6)	-6990 (3)	-6736 (9)	70 (2)
C (21)	-977 (4)	-8426 (3)	-9187 (7)	62 (2)
C (22)	-183 (5)	-8913 (4)	-9661 (8)	73 (2)
C (23)	710 (6)	-8750 (5)	-10715 (11)	97 (2)
C (24)	819 (9)	-8090 (6)	-11282 (10)	105 (3)
C (25)	62 (8)	-7609 (7)	-10833 (10)	94 (3)
C (26)	-865 (6)	-7764 (4)	-9800 (8)	73 (2)

information was provided to the researcher (i.e. James C. Adrian), who synthesized the compounds, and was used in his further work described elsewhere.³⁰

CHAPTER VIII

CONCLUSIONS

The focus of this thesis was mainly on the synthesis and single crystal X-ray analysis of Ca_2NF . A significant bulk of the work centered on the technical problems associated with mounting the highly air sensitive crystals for X-ray analysis. It was discovered that nitride-fluorides will react with the epoxy typically used for mounting crystals, and apparently also with ions present in glass capillary tubes. Success was achieved only when silica capillary tubes were used in place of glass, and petroleum jelly was used in place of epoxy. The mounting technique developed in this project will be central to the success of future studies involving nitride-fluoride materials.

This work apparently represents the first successful synthesis of single crystalline inorganic nitride-fluoride samples suitable for X-ray analysis. Certainly, no single crystal structures of an inorganic nitride-fluoride compound have previously been reported. The present study found through single crystal X-ray diffraction that Ca_2NF has a tetragonal structure similar to that of $\text{L-Mg}_2\text{NF}$, as opposed to the cubic CaO (i.e. rocksalt-type) structure originally proposed in the literature. The structure is intermediate between the ZnS - (with zinc 4-coordinated) and NaCl - (with sodium six-coordinated) type structures, having calcium in an essentially five-coordinated site. By implication, Sr_2NF and Ba_2NF are likely isostructural with $\text{L-Mg}_2\text{NF}$ as well.

An unusual aspect of this study was the successful structure refinement of the partially polycrystalline Ca_2NF sample. The results are an indication of the significant advantages that the more recently developed CCD systems have over conventional serial detector systems. The CCD area detector diffractometer method provided the sensitivity, data collection speed, and data analysis capabilities which were essential for the successful structure determination of the sample.

Finally, the work involving the crystal structure determinations of the three organic samples discussed in Chapter VII illustrates the significance of single crystal X-ray diffraction in elucidating problems of importance to organic chemists. Knowledge of crystal structures of molecular solids provides important clues and explanations regarding the properties of the molecules themselves in non-crystalline environments.

REFERENCES

1. Weller, Mark T. *Inorganic Materials Chemistry*; Oxford University: New York, 1994.
2. T.G. Bednorz and K.A. Muller, *Z. Phys.* **1986**, *B64*, 189.
3. M.K. Chu, J.R. Ashborn, C.J. Torng, P.H. Hor, R.C. Meng, L.Gao, Z.J. Huang, Y.Q. Wang and C.W. Chu, *Phys. Rev. Lett.* **1987**, *58*, 908.
4. Berry, Stephen R.; Rice, Stuart A.; Ross, John. *Physical Chemistry*; John Wiley & Sons: New York, 1980; p 35.
5. Laidler, Keith J.; Meiser, John H. *Physical Chemistry*; Houghton Mifflin: Boston, 1995; p 762.
6. Siemens Industrial Automation, Inc. Hi-Star Area Detector Pamphlet. Analytical Instrumentation, Madison, Wisconsin 53719-1173.
7. Siemens Energy & Automation, Inc. XSCANS VERSION 2.2 Software Tutorial/Users Guide. Analytical Instrumentation, Madison, Wisconsin 54719-1173; pg. 6-1.
8. Clegg, William. *Crystal Structure Determination*; Oxford University: New York, 1998.
9. West, Anthony R. *Basic Solid State Chemistry*. John Wiley & Sons, p 36, New York, (1984).
10. Andersson, S. "Magnesium Nitride Fluorides." *J. Solid State Chem.* **1970**, *1*, 306-309.
11. Erlich, P.; Linz, W.; Seifert, H.J. "Nitridfluoride der schweren Erdalkalimetalle." *Naturwissenschaften.* **1970**, *58*, 219-220.
12. Guler, L. B.S. Research Report, Youngstown State University, 1997.
13. Potkonicky, J. M.S. Thesis, Youngstown State University, Dec. 1997.
14. Marchand; Lang. "Zinc Fluoride Nitride." *Mater. Res. Bull.* **1971**, *6*, 845.
15. Jung; Juza. "Uranium Fluoride Nitride." *Z. Anorg. Allg. Chem.* **1973**, *399*, 148.

16. Juza; Sievers. "Thorium Fluoride Nitride." *Z. Anorg. Allg. Chem.* **1968**, 363, 258.
17. Lavarle; Steele; Smith, J. "Technetium Nitrogen Fluoride." *ZJ. Inorg. Nucl. Chem.* **1966**, 28, 260.
18. Withers; Schmid; Thomson. "A Composite Modulated Structure Approach to the Lanthanide Oxide Fluoride, Uranium Nitride Fluoride and Zirconium Nitride Fluoride Solid-Solution Fields." *Acta Crystallogr., Sect. B.* **1993**, 49, 941-951.
19. Wustefeld, Claus; Vogt, Thomas; Lochner, Ulrich; Strahle, Joachim; Fuess, Hartmut. "Synthesis of TiNF and Structure Determination by Powder Diffraction using Synchrotron Radiation." *Angewandte Chemie.* **1998**, 27, 929-930.
20. Shriver, D. F.; Drezdson, M A. *The Manipulation of Air-Sensitive Compounds*; John Wiley & Sons: New York, 1986; p 63.
21. Brese, N.E. and O'Keefe, M."Bond-Valence Parameters for Solids." *Acta Cryst.* **1991**, B47, 192-197.
22. Boge, T.C. and George, G. I. "The Medicinal Chemistry of β -Amino Acids: Paclitaxel as an Illustrative Example." *Enantioselective Synthesis of β -Amino Acids*; Juaristi, E. Ed.; Wiley-VCH, Inc.: New York, 1996; pp. 1-43.
23. Shandar, B.B.; Kirkup, M.P.; McCombie, S.W.; Clader, J.W.; Ganguly, A.K. *Tetrahedron Lett.* **1996**, 37, 613-618.
24. Seebach, D.; Overhand, M.; Kuhnle, F.N.M.; Martinoni, B.; Oberer, L.; Hommel, U.; Widmer, H. *Helv. Chim. Acta* **1996**, 79, 913-941.
25. Appela, D.H.; Christianson, L.A.; Karle, I.L.; Powel, D.R.; Gellman, S.H. *J. Am. Chem. Soc.* **1996**, 118, 13071-13072.
26. D.C.Cole *Tetrahedron* **1994**, 50, 9517-9582.
27. Juaristi, E. Ed; *Enantioselective Synthesis of β -Amino Acids*; Wiley-VCH, Inc.; New York, 1996
28. Mukai, C; Kim, I. J.; Hanaoka, M. *Tetrahedron Lett.* **1992**, 93, 1007-1010.
29. Annunziata, R.; Cinquini, M.; Cozzi, F.; Borgia, A.L. *J. Org. Chem.* **1992**, 57, 6339-6342.

30. Adrian, James C, Jr; Barkin, Julia L.; Fox, Richard J.; Chick, Jennifer E.; Hunter, Allen D.; Nicklow, Rhea A. "Chlorotitanium Enolate Addition to Aldimines: A Stereoselective Route to α -Oxy- β -Substituted- β -Amino Esters." *J. Org. Chem.*, in press.

APPENDIX A**CRYSTALLOGRAPHY DATA FOR Ca_2NF**

Table A-1**Bond lengths [Å] and angles [°] for Ca₂NF.**

Ca(1)-N(1)#1	2.4000(12)	Ca(1)-N(1)#2	2.4616(5)
Ca(1)-F(1)#3	2.4616(5)	Ca(1)-F(1)	2.4616(5)
Ca(1)-N(1)	2.4616(5)	Ca(1)-F(1)#4	2.8579(13)
Ca(1)-Ca(1)#1	3.2742(15)	Ca(1)-Ca(1)#5	3.2742(15)
Ca(1)-Ca(1)#6	3.4962(7)	Ca(1)-Ca(1)#7	3.4962(7)
Ca(1)-Ca(1)#8	3.4962(7)	Ca(1)-Ca(1)#9	3.4962(7)
F(1)-Ca(1)#8	2.4616(5)	F(1)-Ca(1)#10	2.4616(5)
F(1)-Ca(1)#7	2.4616(5)	F(1)-Ca(1)#4	2.8579(13)
F(1)-Ca(1)#11	2.8579(13)	N(1)-Ca(1)#12	2.4000(12)
N(1)-Ca(1)#1	2.4000(12)	N(1)-Ca(1)#9	2.4616(5)
N(1)-Ca(1)#13	2.4616(5)	N(1)-Ca(1)#7	2.4616(5)
N(1)#1-Ca(1)-N(1)#2	95.34(2)	N(1)#1-Ca(1)-F(1)#3	95.34(2)
N(1)#2-Ca(1)-F(1)#3	89.504(5)	N(1)#1-Ca(1)-F(1)	95.34(2)
N(1)#2-Ca(1)-F(1)	89.504(4)	F(1)#3-Ca(1)-F(1)	169.33(5)
N(1)#1-Ca(1)-N(1)	95.34(2)	N(1)#2-Ca(1)-N(1)	169.33(5)
F(1)#3-Ca(1)-N(1)	89.504(4)	F(1)-Ca(1)-N(1)	89.504(5)
N(1)#1-Ca(1)-F(1)#4	180.0	N(1)#2-Ca(1)-F(1)#4	84.66(2)
F(1)#3-Ca(1)-F(1)#4	84.66(2)	F(1)-Ca(1)-F(1)#4	84.66(2)
N(1)-Ca(1)-F(1)#4	84.66(2)	N(1)#1-Ca(1)-Ca(1)#1	48.46(3)
N(1)#2-Ca(1)-Ca(1)#1	143.80(5)	F(1)#3-Ca(1)-Ca(1)#1	93.536(14)
F(1)-Ca(1)-Ca(1)#1	93.536(14)	N(1)-Ca(1)-Ca(1)#1	46.872(11)
F(1)#4-Ca(1)-Ca(1)#1	131.54(3)	N(1)#1-Ca(1)-Ca(1)#5	48.46(3)
N(1)#2-Ca(1)-Ca(1)#5	46.872(11)	F(1)#3-Ca(1)-Ca(1)#5	93.536(14)
F(1)-Ca(1)-Ca(1)#5	93.536(14)	N(1)-Ca(1)-Ca(1)#5	143.80(5)
F(1)#4-Ca(1)-Ca(1)#5	131.54(3)	Ca(1)#1-Ca(1)-Ca(1)#5	96.93(6)
N(1)#1-Ca(1)-Ca(1)#6	97.53(3)	N(1)#2-Ca(1)-Ca(1)#6	44.752(2)
F(1)#3-Ca(1)-Ca(1)#6	44.752(2)	F(1)-Ca(1)-Ca(1)#6	133.298(15)
N(1)-Ca(1)-Ca(1)#6	133.298(15)	F(1)#4-Ca(1)-Ca(1)#6	82.47(3)
Ca(1)#1-Ca(1)-Ca(1)#6	127.70(4)	Ca(1)#5-Ca(1)-Ca(1)#6	64.030(13)
N(1)#1-Ca(1)-Ca(1)#7	97.53(3)	N(1)#2-Ca(1)-Ca(1)#7	133.298(15)
F(1)#3-Ca(1)-Ca(1)#7	133.298(15)	F(1)-Ca(1)-Ca(1)#7	44.752(2)
N(1)-Ca(1)-Ca(1)#7	44.752(2)	F(1)#4-Ca(1)-Ca(1)#7	82.47(3)
Ca(1)#1-Ca(1)-Ca(1)#7	64.030(13)	Ca(1)#5-Ca(1)-Ca(1)#7	127.70(4)
Ca(1)#6-Ca(1)-Ca(1)#7	164.95(7)	N(1)#1-Ca(1)-Ca(1)#8	97.53(3)
N(1)#2-Ca(1)-Ca(1)#8	44.752(2)	F(1)#3-Ca(1)-Ca(1)#8	133.298(15)
F(1)-Ca(1)-Ca(1)#8	44.752(2)	N(1)-Ca(1)-Ca(1)#8	133.298(15)
F(1)#4-Ca(1)-Ca(1)#8	82.47(3)	Ca(1)#1-Ca(1)-Ca(1)#8	127.70(4)
Ca(1)#5-Ca(1)-Ca(1)#8	64.030(13)	Ca(1)#6-Ca(1)-Ca(1)#8	89.017(9)
Ca(1)#7-Ca(1)-Ca(1)#8	89.017(9)	N(1)#1-Ca(1)-Ca(1)#9	97.53(3)
N(1)#2-Ca(1)-Ca(1)#9	133.298(15)	F(1)#3-Ca(1)-Ca(1)#9	44.752(2)
F(1)-Ca(1)-Ca(1)#9	133.298(15)	N(1)-Ca(1)-Ca(1)#9	44.752(2)
F(1)#4-Ca(1)-Ca(1)#9	82.47(3)	Ca(1)#1-Ca(1)-Ca(1)#9	64.030(13)
Ca(1)#5-Ca(1)-Ca(1)#9	127.70(4)	Ca(1)#6-Ca(1)-Ca(1)#9	89.017(9)
Ca(1)#7-Ca(1)-Ca(1)#9	89.017(9)	Ca(1)#8-Ca(1)-Ca(1)#9	164.95(7)
Ca(1)#8-F(1)-Ca(1)#10	90.496(5)	Ca(1)#8-F(1)-Ca(1)	90.496(5)
Ca(1)#10-F(1)-Ca(1)	169.33(5)	Ca(1)#8-F(1)-Ca(1)#7	169.33(5)
Ca(1)#10-F(1)-Ca(1)#7	90.496(5)	Ca(1)-F(1)-Ca(1)#7	90.496(5)
Ca(1)#8-F(1)-Ca(1)#4	84.66(2)	Ca(1)#10-F(1)-Ca(1)#4	95.34(2)
Ca(1)-F(1)-Ca(1)#4	95.34(2)	Ca(1)#7-F(1)-Ca(1)#4	84.66(2)
Ca(1)#8-F(1)-Ca(1)#11	95.34(2)	Ca(1)#10-F(1)-Ca(1)#11	84.66(2)
Ca(1)-F(1)-Ca(1)#11	84.66(2)	Ca(1)#7-F(1)-Ca(1)#11	95.34(2)
Ca(1)#4-F(1)-Ca(1)#11	180.0	Ca(1)#12-N(1)-Ca(1)#1	180.0
Ca(1)#12-N(1)-Ca(1)#9	84.66(2)	Ca(1)#1-N(1)-Ca(1)#9	95.34(2)
Ca(1)#12-N(1)-Ca(1)#13	95.34(2)	Ca(1)#1-N(1)-Ca(1)#13	84.66(2)

Table A-2**Observed and calculated structure factors for Ca₂NF.**

h	k	l	10Fo	10Fc	10a	h	k	l	10Fo	10Fc	10a	h	k	l	10Fo	10Fc	10a	h	k	l	10Fo	10Fc	10a						
0	2	0	1671	1545	49	0	4	2	0	3	1	4	4	4	484	474	11	0	1	7	471	464	5	0	5	9	252	260	11
2	2	0	1104	1225	11	2	4	2	9	2	9	1	5	4	34	6	17	1	2	7	406	402	4	1	1	10	46	11	24
0	4	0	948	878	42	1	5	2	362	361	7	3	5	4	0	3	1	0	3	7	323	320	8	0	2	10	0	2	1
2	4	0	755	771	22	3	5	2	322	319	6	0	6	4	406	441	16	2	3	7	323	324	2	1	3	10	44	4	11
4	4	0	564	579	8	0	6	2	53	4	19	0	1	5	390	405	7	1	4	7	292	293	4	3	3	10	0	5	1
0	6	0	558	537	29	2	6	2	29	3	28	1	2	5	337	340	3	3	4	7	259	252	3	0	4	10	30	6	30
2	6	0	518	500	17	0	1	3	382	378	9	0	3	5	287	290	6	0	5	7	298	298	10	2	4	10	0	4	1
0	1	1	93	80	3	1	2	3	308	308	4	2	3	5	251	260	2	2	5	7	240	240	4	0	1	11	364	347	9
1	2	1	46	52	3	0	3	3	267	265	8	1	4	5	245	243	5	0	0	8	528	523	11	1	2	11	313	320	3
0	3	1	30	35	8	2	3	3	216	226	3	3	4	8	211	206	3	0	2	8	447	452	3	0	3	11	305	298	7
2	3	1	28	34	10	1	4	3	185	191	3	0	5	5	204	198	9	2	2	8	389	399	7	2	3	11	271	279	3
1	4	1	62	61	7	3	4	3	186	187	4	2	8	9	193	186	4	1	3	8	0	4	1	0	0	12	51	57	50
3	4	1	43	35	12	0	5	3	148	147	8	1	6	5	175	176	12	0	4	8	334	327	10	0	2	12	35	50	34
0	5	1	43	23	15	2	5	3	187	182	4	1	1	6	312	311	4	2	4	8	300	301	4	2	2	12	44	45	26
2	5	1	42	25	13	1	6	3	129	116	8	0	2	4	19	2	19	1	5	0	0	8	1	1	3	12	0	3	1
4	5	1	0	26	1	0	0	4	1584	1416	13	1	3	6	262	262	3	0	1	9	427	415	8	0	1	13	318	304	6
1	6	1	50	40	15	0	2	4	1351	1110	19	3	3	4	221	229	9	1	2	9	376	376	4	1	2	13	287	285	6
1	1	2	695	670	16	2	2	4	869	916	17	0	4	6	0	6	1	0	3	9	342	344	6						
0	2	2	31	1	8	1	3	4	8	3	1	2	4	6	0	4	1	2	3	9	315	319	3						
1	3	2	528	511	6	0	4	4	492	487	28	1	2	4	199	205	4	1	4	9	297	299	5						
3	3	2	411	418	9	2	4	4	688	615	7	3	5	6	191	184	5	3	4	9	271	263	7						

APPENDIX B**CRYSTALLOGRAPHY DATA FOR 2**

Table B-1**Bond lengths [Å] and angles [°] for 1.**

N-C(21)	1.390(2)	N-C(3)	1.450(2)
N-H(1N)	0.85(2)	O(1)-C(1)	1.328(2)
O(1)-C(4)	1.443(3)	C(1)-O(2)	1.196(2)
C(1)-C(2)	1.497(3)	C(2)-C(3)	1.532(3)
C(2)-H(2B)	0.98(2)	C(2)-H(2A)	1.00(2)
C(3)-C(11)	1.519(2)	C(3)-H(3)	1.00(2)
O(4)-C(22)	1.374(2)	O(4)-C(6)	1.417(3)
C(4)-H(4C)	1.01(4)	C(4)-H(4B)	0.91(4)
C(4)-H(4A)	0.99(5)	C(6)-H(6C)	0.95(3)
C(6)-H(6B)	1.00(3)	C(6)-H(6A)	1.03(3)
C(11)-C(16)	1.383(3)	C(11)-C(12)	1.382(3)
C(12)-C(13)	1.388(3)	C(12)-H(12)	0.96(2)
C(13)-C(14)	1.375(3)	C(13)-H(13)	0.93(3)
C(14)-C(15)	1.367(4)	C(14)-H(14)	0.93(3)
C(15)-C(16)	1.375(3)	C(15)-H(15)	0.94(3)
C(16)-H(16)	0.96(3)	C(21)-C(26)	1.387(3)
C(21)-C(22)	1.403(3)	C(22)-C(23)	1.378(3)
C(23)-C(24)	1.382(4)	C(23)-H(23)	0.92(3)
C(24)-C(25)	1.368(4)	C(24)-H(24)	0.92(3)
C(25)-C(26)	1.381(3)	C(25)-H(25)	1.03(2)
C(26)-H(26)	0.95(2)		
C(21)-N-C(3)	120.54(16)	C(21)-N-H(1N)	115.3(14)
C(3)-N-H(1N)	114.2(14)	C(1)-O(1)-C(4)	117.83(18)
O(2)-C(1)-O(1)	123.45(19)	O(2)-C(1)-C(2)	124.90(19)
O(1)-C(1)-C(2)	111.65(17)	C(1)-C(2)-C(3)	111.36(17)
C(1)-C(2)-H(2B)	109.1(12)	C(3)-C(2)-H(2B)	108.5(12)
C(1)-C(2)-H(2A)	107.1(11)	C(3)-C(2)-H(2A)	109.8(11)
H(2B)-C(2)-H(2A)	111.0(17)	N-C(3)-C(11)	114.74(15)
N-C(3)-C(12)	107.57(16)	C(11)-C(3)-C(2)	111.17(15)
N-C(3)-H(3)	105.7(11)	C(11)-C(3)-H(3)	108.3(10)
C(2)-C(3)-H(3)	109.2(10)	C(22)-O(4)-C(6)	117.3(2)
O(1)-C(4)-H(4C)	105(2)	O(1)-C(4)-H(4B)	114(2)
H(4C)-C(4)-H(4B)	123(3)	O(1)-C(4)-H(4A)	113(2)
H(4C)-C(4)-H(4A)	108(3)	H(4B)-C(4)-H(4A)	93(3)
O(4)-C(6)-H(6C)	108.3(16)	O(4)-C(6)-H(6B)	103.7(17)
H(6C)-C(6)-H(6B)	111(2)	O(4)-C(6)-H(6A)	109.8(19)
H(6C)-C(6)-H(6A)	111(2)	H(6B)-C(6)-H(6A)	113(2)
C(16)-C(11)-C(12)	118.18(19)	C(16)-C(11)-C(3)	120.32(18)
C(12)-C(11)-C(3)	121.49(17)	C(11)-C(12)-C(13)	120.5(2)
C(11)-C(12)-H(12)	118.2(12)	C(13)-C(12)-H(12)	121.3(13)
C(14)-C(13)-C(12)	120.1(2)	C(14)-C(13)-H(13)	120.5(15)
C(12)-C(13)-H(13)	119.4(15)	C(15)-C(14)-C(13)	119.8(2)
C(15)-C(14)-H(14)	119.7(15)	C(13)-C(14)-H(14)	121.4(15)
C(14)-C(15)-C(16)	120.0(2)	C(14)-C(15)-H(15)	117.3(15)
C(16)-C(15)-H(15)	122.6(15)	C(15)-C(16)-C(11)	121.3(2)
C(15)-C(16)-H(16)	121.2(14)	C(11)-C(16)-H(16)	117.4(14)
C(26)-C(21)-N	123.88(17)	C(26)-C(21)-C(22)	117.82(18)
N-C(21)-C(22)	118.26(17)	C(23)-C(22)-O(4)	125.24(19)
C(23)-C(22)-C(21)	120.8(2)	O(4)-C(22)-C(21)	113.96(17)
C(22)-C(23)-C(24)	119.8(2)	C(22)-C(23)-H(23)	116.7(16)
C(24)-C(23)-H(23)	123.5(16)	C(25)-C(24)-C(23)	120.4(2)
C(25)-C(24)-H(24)	119.0(17)	C(23)-C(24)-H(24)	120.6(17)
C(24)-C(25)-C(26)	120.0(2)	C(24)-C(25)-H(25)	121.7(13)
C(26)-C(25)-H(25)	118.2(13)	C(25)-C(26)-C(21)	121.2(2)

Table B-2

Anisotropic displacement parameters [$\text{\AA}^2 \times 10^3$] for 1. The anisotropic displacement factor exponent takes the form: $-2\pi^2 \{ (ha^*)^2 U_{11} + \dots + 2hka^*b^*U_{12} \}$

	U11	U22	U33	U23	U13	U12
N	55 (1)	47 (1)	53 (1)	-1 (1)	18 (1)	-8 (1)
O (1)	61 (1)	82 (1)	53 (1)	11 (1)	6 (1)	-6 (1)
C (1)	57 (1)	59 (1)	43 (1)	-8 (1)	11 (1)	-7 (1)
O (2)	66 (1)	108 (1)	60 (1)	9 (1)	17 (1)	-17 (1)
C (2)	62 (1)	54 (1)	46 (1)	-3 (1)	12 (1)	0 (1)
C (3)	51 (1)	47 (1)	44 (1)	-1 (1)	10 (1)	-5 (1)
O (4)	66 (1)	49 (1)	82 (1)	1 (1)	9 (1)	-12 (1)
C (4)	84 (2)	92 (2)	54 (1)	16 (1)	6 (1)	7 (2)
C (6)	82 (2)	57 (2)	127 (3)	9 (2)	4 (2)	-17 (1)
C (11)	53 (1)	43 (1)	46 (1)	-3 (1)	15 (1)	-1 (1)
C (12)	59 (1)	50 (1)	55 (1)	1 (1)	13 (1)	-1 (1)
C (13)	73 (1)	67 (1)	50 (1)	2 (1)	9 (1)	11 (1)
C (14)	88 (2)	64 (1)	61 (1)	15 (1)	30 (1)	11 (1)
C (15)	80 (2)	70 (2)	74 (2)	9 (1)	29 (1)	-16 (1)
C (16)	64 (1)	64 (1)	61 (1)	2 (1)	14 (1)	-15 (1)
C (21)	57 (1)	45 (1)	39 (1)	5 (1)	9 (1)	2 (1)
C (22)	58 (1)	45 (1)	50 (1)	5 (1)	3 (1)	2 (1)
C (23)	84 (2)	52 (1)	64 (1)	-6 (1)	-3 (1)	9 (1)
C (24)	90 (2)	69 (2)	64 (1)	-7 (1)	12 (1)	28 (1)
C (25)	69 (2)	72 (2)	64 (1)	6 (1)	18 (1)	20 (1)
C (26)	62 (1)	52 (1)	55 (1)	6 (1)	12 (1)	2 (1)

Table B-3

**Hydrogen coordinates ($\times 10^4$) and isotropic displacement parameters ($\text{\AA}^2 \times 10^3$)
for 1.**

	x	y	z	U(eq)
H(3)	1491(19)	4804(11)	430(20)	49(5)
H(2B)	2766(19)	3785(14)	-450(20)	62(6)
H(2A)	4040(20)	4284(12)	300(20)	60(6)
H(26)	669(19)	5536(14)	2050(20)	57(5)
H(12)	4080(20)	4701(14)	3490(20)	64(6)
H(13)	4120(20)	3875(14)	5650(30)	79(7)
H(16)	800(20)	3625(15)	1610(30)	85(7)
H(25)	-270(20)	6473(14)	3540(20)	78(7)
H(15)	890(20)	2793(16)	3820(30)	86(8)
H(1N)	3670(20)	5629(12)	1270(20)	54(6)
H(14)	2520(20)	2917(16)	5760(30)	85(7)
H(6C)	4280(20)	8097(17)	1980(30)	87(8)
H(23)	2980(20)	7864(18)	3850(30)	90(8)
H(24)	950(20)	7647(18)	4430(30)	95(8)
H(4C)	730(40)	5490(20)	-3960(40)	152(14)
H(6B)	5590(30)	7592(17)	2070(30)	97(9)
H(6A)	4990(30)	7790(20)	3650(40)	125(12)
H(4B)	2200(40)	5340(20)	-4300(40)	145(14)
H(4A)	2010(40)	6030(30)	-3450(50)	167(16)

Table B-4

Continued.

h k l 10Fo 10Fc 10e				h k l 10Fo 10Fc 10e				h k l 10Fo 10Fc 10e				h k l 10Fo 10Fc 10e							
-3 15 1	7	12	7	10 2 2	8	9	8	-10 7 2	3	1	2	2 11 2	93	88	4	7 1 3	35	38	2
-2 15 1	125	124	3	-11 3 2	42	39	5	-9 7 2	94	79	3	3 11 2	79	70	3	0 1 3	49	44	2
-1 15 1	8	4	8	-10 3 2	33	37	2	-8 7 2	92	98	2	4 11 2	92	85	3	9 1 3	9	21	8
0 15 1	73	74	4	-9 3 2	27	24	2	-7 7 2	123	120	3	5 11 2	0	0	1	10 1 3	5	2	5
1 15 1	8	18	8	-8 3 2	71	69	4	-6 7 2	89	85	1	6 11 2	65	66	4	-11 2 3	44	46	6
2 15 1	58	56	2	-7 3 2	39	34	1	-5 7 2	56	53	1	7 11 2	97	93	3	-10 2 3	12	9	6
3 15 1	5	5	5	-6 3 2	126	120	1	-4 7 2	105	118	3	8 11 2	0	4	1	-9 2 3	105	106	2
4 15 1	11	12	10	-5 3 2	396	387	3	-3 7 2	43	46	1	-8 12 2	2	6	2	-8 2 3	56	56	1
5 15 1	0	8	1	-4 3 2	214	220	4	-2 7 2	277	278	8	-7 12 2	22	34	3	-7 2 3	60	54	3
-4 16 1	8	10	7	-3 3 2	279	282	3	-1 7 2	97	98	5	-6 12 2	0	14	1	-6 2 3	13	20	3
-3 16 1	43	42	4	-2 3 2	460	482	10	0 7 2	247	286	8	-5 12 2	9	10	8	-5 2 3	131	131	1
-2 16 1	64	65	5	-1 3 2	93	87	3	1 7 2	88	85	3	-4 12 2	11	23	6	-4 2 3	68	67	1
-1 16 1	7	1	6	0 3 2	790	791	31	2 7 2	42	35	2	-3 12 2	0	9	1	-3 2 3	9	9	4
0 16 1	89	91	4	1 3 2	74	80	3	3 7 2	118	117	4	-2 12 2	12	7	4	-2 2 3	223	225	3
1 16 1	91	87	3	2 3 2	467	476	14	4 7 2	58	58	4	-1 12 2	132	132	4	-1 2 3	17	17	1
2 16 1	113	107	5	3 3 2	21	17	1	5 7 2	131	129	1	0 12 2	99	94	3	0 2 3	233	252	3
3 16 1	36	38	2	4 3 2	167	169	8	6 7 2	116	113	7	1 12 2	180	173	7	1 2 3	50	51	1
4 16 1	36	34	2	5 3 2	31	34	3	7 7 2	188	184	7	2 12 2	41	37	1	2 2 3	144	144	2
-2 17 1	0	13	1	6 3 2	55	54	1	8 7 2	158	144	5	3 12 2	51	49	1	3 2 3	8	1	7
-1 17 1	41	39	6	7 3 2	41	39	1	9 7 2	5	0	6	4 12 2	16	17	5	4 2 3	146	148	2
0 17 1	42	40	5	8 3 2	56	56	2	-10 8 2	3	0	2	5 12 2	14	15	5	5 2 3	11	9	11
1 17 1	57	52	2	9 3 2	35	38	2	-9 8 2	71	68	1	6 12 2	0	0	1	6 2 3	95	98	3
2 17 1	39	39	2	10 3 2	28	29	3	-8 8 2	125	126	1	7 12 2	41	43	5	7 2 3	49	47	3
-11 0 2	43	51	2	-11 4 2	76	75	3	-7 8 2	54	53	1	-7 13 2	58	55	2	8 2 3	14	15	1
-10 0 2	85	80	3	-10 4 2	98	98	1	-6 8 2	7	1	7	-6 13 2	0	10	1	9 2 3	20	25	3
-9 0 2	74	75	1	-9 4 2	103	104	1	-5 8 2	96	99	1	-5 13 2	22	24	3	10 2 3	46	53	2
-8 0 2	94	49	3	-8 4 2	61	59	2	-4 8 2	50	46	1	-4 13 2	73	68	4	-11 3 3	38	38	4
-7 0 2	161	156	4	-7 4 2	121	113	1	-3 8 2	265	260	18	-3 13 2	34	33	3	-10 3 3	47	42	2
-6 0 2	177	170	2	-6 4 2	72	72	1	-2 8 2	220	231	4	-2 13 2	127	131	5	-9 3 3	4	7	4
-5 0 2	56	84	1	-5 4 2	158	153	2	-1 8 2	204	209	4	-1 13 2	116	110	4	-8 3 3	164	161	9
-4 0 2	128	128	1	-4 4 2	77	84	1	0 8 2	172	179	5	0 13 2	89	90	2	-7 3 3	108	103	3
-3 0 2	256	170	2	-3 4 2	183	188	6	1 8 2	38	41	1	1 13 2	60	58	2	-6 3 3	55	57	1
-2 0 2	36	37	1	-2 4 2	4	3	3	2 8 2	21	18	2	2 13 2	24	27	2	-5 3 3	146	135	2
-1 0 2	227	210	3	-1 4 2	293	301	10	3 8 2	156	150	7	3 13 2	62	61	5	-4 3 3	101	104	1
0 0 2	1516	1399	43	0 4 2	319	238	5	4 8 2	75	71	2	4 13 2	24	32	5	-3 3 3	93	91	1
1 0 2	261	282	4	1 4 2	882	861	30	5 8 2	66	63	3	5 13 2	24	28	8	-2 3 3	239	241	3
2 0 2	186	188	7	2 4 2	91	95	2	6 8 2	108	106	3	6 13 2	52	56	3	-1 3 3	419	428	6
3 0 2	790	773	37	3 4 2	124	121	7	7 8 2	7	3	6	-6 14 2	31	37	2	0 3 3	201	207	4
4 0 2	292	302	11	4 4 2	37	38	1	8 8 2	69	65	7	-5 14 2	65	67	1	1 3 3	671	667	13
5 0 2	436	420	16	5 4 2	121	120	2	9 8 2	14	18	4	-4 14 2	20	18	9	2 3 3	86	87	2
6 0 2	108	101	3	6 4 2	168	160	8	-9 9 2	183	187	1	-3 14 2	14	12	4	3 3 3	20	26	2
7 0 2	27	22	2	7 4 2	14	9	4	-8 9 2	131	135	1	-2 14 2	54	55	1	4 3 3	179	175	5
8 0 2	0	7	1	8 4 2	99	94	4	-7 9 2	44	52	1	-1 14 2	48	47	1	5 3 3	31	29	1
9 0 2	44	46	1	9 4 2	35	34	2	-6 9 2	168	163	2	0 14 2	5	5	7	6 3 3	47	42	1
10 0 2	45	48	2	10 4 2	48	43	2	-5 9 2	9	3	8	1 14 2	5	5	5	7 3 3	10	15	9
-11 1 2	25	29	9	-11 5 2	57	57	2	-4 9 2	34	42	1	2 14 2	12	11	5	8 3 3	14	7	3
-10 1 2	38	39	2	-10 5 2	14	19	5	-3 9 2	92	90	2	3 14 2	54	56	2	9 3 3	118	117	4
-9 1 2	45	46	1	-9 5 2	46	45	1	-2 9 2	67	68	1	4 14 2	16	20	4	10 3 3	56	54	1
-8 1 2	74	74	1	-8 5 2	138	138	2	-1 9 2	118	121	3	5 14 2	81	82	1	-11 4 3	8	7	7
-7 1 2	6	5	6	-7 5 2	62	58	1	0 9 2	247	247	4	6 14 2	10	14	7	-10 4 3	40	40	4
-6 1 2	90	85	1	-6 5 2	79	82	1	1 9 2	91	98	1	-5 15 2	46	53	2	-9 4 3	80	80	3
-5 1 2	344	341	4	-5 5 2	326	311	3	2 9 2	52	47	2	-4 15 2	9	1	8	-8 4 3	117	113	1
-4 1 2	52	54	1	-4 5 2	136	146	5	3 9 2	121	114	8	-3 15 2	120	111	4	-7 4 3	143	137	5
-3 1 2	87	88	1	-3 5 2	428	437	11	4 9 2	24	23	6	-2 15 2	45	48	2	-6 4 3	113	107	5
-2 1 2	542	569	6	-2 5 2	131	136	1	5 9 2	126	124	8	-1 15 2	182	172	6	-5 4 3	50	49	1
-1 1 2	417	431	5	-1 5 2	162	164	4	6 9 2	33	34	2	0 15 2	96	93	1	-4 4 3	431	429	6
0 1 2	15	11	5	0 5 2	160	168	7	7 9 2	61	63	5	1 15 2	123	115	5	-3 4 3	196	193	5
1 1 2	892	877	29	1 5 2	168	172	2	8 9 2	5	8	4	2 15 2	12	16	6	-2 4 3	362	373	5
2 1 2	328	332	7	2 5 2	10	9	3	9 9 2	87	82	5	3 15 2	11	18	7	-1 4 3	29	28	1
3 1 2	56	55	1	3 5 2	147	144	8	-9 10 2	8	13	8	4 15 2	5	0	4	0 4 3	217	213	3
4 1 2	191	192	9	4 5 2	13	14	3	-8 10 2	12	26	5	-4 16 2	12	10	5	1 4 3	495	519	7
5 1 2	117	120	3	5 5 2	0	5	1	-7 10 2	111	107	2	-3 16 2	69	67	4	2 4 3	49	43	1
6 1 2	147	143	2	6 5 2	172	179	9	-6 10 2	140	140	3	-2 16 2	17	23	4	3 4 3	310	312	6
7 1 2	61	63	4	7 5 2	39	38	4	-5 10 2	17	22	10	-1 16 2	12	6	6	4 4 3	202	208	3
8 1 2	27	26	2	8 5 2	164	165	12	-4 10 2	41	43	1	0 16 2	58	58	3	5 4 3	101	100	2
9 1 2	45	43	2	9 5 2	63	61	1	-3 10 2	39	37	1	1 16 2	91	90	6	6 4 3	58	59	1
10 1 2	0	7	1	10 5 2	49	53	2	-2 10 2	110	105	1	2 16 2	26	27	5	7 4 3	140	134	2
-11 2 2	74	73	4	-10 6 2	40	45	2	-1 10 2	9	13	9	3 16 2	4	5	4	8 4 3	19	16	3
-10 2 2	45	40	2	-9 6 2	163	161	2	0 10 2	237	238	10	-1 17 2	29	35	6	9 4 3	40	47	2
-9 2 2	122	121	2	-8 6 2	137	134	2	1 10 2	116	118	1	0 17 2	29	29	2	-11 5 3	14	16	7
-8 2 2	16	5	5	-7 6 2	157	152	2	2 10 2	208	182	4	-11 1 3	32	31	5	-10 5 3	42	49	2
-7 2 2	0	0	1	-6 6 2	122	108	1	3 10 2	38	37	1	-10 1 3	124	121	4	-9 5 3	118	110	3
-6 2 2	89	87	1	-5 6 2	156	154	3	4 10 2	51	49	1	-9 1 3	14	17	3	-8 5 3	12	3	5
-5 2 2	114	119	1	-4 6 2	267	275	5	5 10 2	101	100	4	-8 1 3	51	46	1	-7 5 3	149	147	4
-4 2 2	83	81	1	-3 6 2	233	237	5	6 10 2	11	13	5	-7 1 3	23	22	2	-6 5 3	75	73	1
-3 2 2	168	164	2	-2 6 2	105	108	6	7 10 2	0	4	1	-6 1 3	240	246	6	-5 5 3	67	71	1

Table B-4

Continued.

h k l 10Fo 10Fc 10s					h k l 10Fo 10Fc 10s					h k l 10Fo 10Fc 10s					h k l 10Fo 10Fc 10s														
1	15	4	0	2	1	0	5	5	89	85	5	4	10	5	89	84	4	0	2	6	0	1	1	6	7	6	13	18	5
2	15	4	0	1	0	1	8	5	18	24	3	5	10	5	55	55	2	1	2	6	69	75	2	-8	8	6	11	2	11
-10	1	5	106	105	6	2	5	5	396	385	16	6	10	5	69	71	4	2	2	6	112	114	1	-7	8	6	35	31	2
-9	1	5	38	43	3	3	5	5	19	21	2	-7	11	5	31	37	3	3	2	6	153	148	2	-6	8	6	156	156	1
-8	1	5	16	17	5	4	5	5	307	308	6	-6	11	5	74	73	1	4	2	6	220	213	3	-5	8	6	26	38	1
-7	1	5	80	78	1	5	5	5	62	59	3	-5	11	5	151	152	4	5	2	6	108	113	1	-4	8	6	153	160	3
-6	1	5	81	75	1	6	5	5	180	99	6	-4	11	5	73	68	4	6	2	6	87	97	1	-3	8	6	32	33	2
-5	1	5	190	192	2	7	5	5	0	1	1	-3	11	5	19	20	2	7	2	6	38	40	2	-2	8	6	35	34	2
-4	1	5	205	289	3	8	5	5	70	70	1	-2	11	5	95	93	2	-9	3	6	8	7	0	-1	8	6	39	46	1
-3	1	5	147	147	1	-10	6	5	30	32	2	-1	11	5	0	3	1	-8	3	6	79	74	2	0	8	6	30	28	2
-2	1	5	96	103	1	-8	6	5	62	43	1	0	11	5	62	61	1	-7	3	6	34	32	1	1	8	6	115	105	1
-1	1	5	49	46	1	-8	6	5	99	99	1	1	11	5	98	92	4	-6	3	6	17	21	7	2	8	6	67	58	1
0	1	5	252	242	3	-7	6	5	103	103	1	2	11	5	91	82	2	-5	3	6	91	93	2	3	8	6	234	226	1
1	1	5	107	101	4	-6	6	5	78	74	3	3	11	5	42	41	2	-4	3	6	209	205	2	4	8	6	26	25	3
2	1	5	66	64	1	-5	6	5	47	42	3	4	11	5	77	76	1	-3	3	6	30	27	2	5	8	6	55	56	2
3	1	5	74	90	2	-4	6	5	0	0	1	5	11	5	49	50	2	-2	3	6	67	68	2	6	8	6	11	13	5
4	1	5	110	108	2	-3	6	5	144	140	6	-6	12	5	77	78	3	-1	3	6	64	65	1	-7	9	6	8	10	7
5	1	5	99	91	4	-2	6	5	83	65	1	-5	12	5	74	76	3	0	3	6	148	148	1	-6	9	6	14	23	0
6	1	5	84	84	3	-1	6	5	61	61	2	-4	12	5	11	6	5	1	3	6	30	30	2	-5	9	6	5	20	6
7	1	5	87	83	2	0	6	5	78	76	1	-3	12	5	54	54	1	2	3	6	119	120	3	-4	9	6	88	85	1
8	1	5	34	42	2	1	6	5	74	70	2	-2	12	5	86	81	1	3	3	6	13	14	8	-3	9	6	16	12	16
-10	2	5	13	17	6	2	6	5	64	69	1	-1	12	5	98	92	2	4	3	6	104	101	1	-2	9	6	104	104	3
-9	2	5	0	3	1	3	6	5	98	101	1	0	12	5	120	121	5	5	3	6	50	49	1	-1	9	6	90	92	1
-8	2	5	40	40	1	4	6	5	211	204	9	1	12	5	148	149	4	6	3	6	23	24	3	0	9	6	23	18	2
-7	2	5	151	152	7	5	6	5	93	91	1	2	12	5	62	60	4	7	3	6	50	54	3	1	9	6	139	135	1
-6	2	5	51	53	1	6	6	5	111	111	6	3	12	5	110	111	1	-9	4	6	11	16	10	2	9	6	58	56	1
-5	2	5	49	49	3	7	6	5	26	24	7	4	12	5	9	11	8	-8	4	6	7	15	7	3	9	6	3	0	3
-4	2	5	11	8	3	-9	7	5	28	32	4	-9	13	5	13	19	2	-7	4	6	164	159	6	4	9	6	34	41	2
-3	2	5	9	12	5	-8	7	5	33	32	2	-6	13	5	25	29	2	-6	4	6	90	97	1	5	9	6	10	16	8
-2	2	5	28	24	1	-7	7	5	109	106	1	-3	13	5	8	6	7	-5	4	6	101	101	1	-7	10	6	0	0	1
-1	2	5	114	118	2	-6	7	5	103	104	1	-2	13	5	32	29	2	-4	4	6	79	82	2	-6	10	6	0	4	1
0	2	5	69	65	1	-5	7	5	51	54	2	-1	13	5	119	128	8	-3	4	6	10	14	6	-5	10	6	11	22	8
1	2	5	0	5	1	-4	7	5	132	130	2	0	13	5	45	43	2	-2	4	6	27	26	2	-4	10	6	28	27	4
2	2	5	17	20	2	-3	7	5	41	40	1	1	13	5	84	82	4	-1	4	6	95	95	1	-3	10	6	0	2	1
3	2	5	0	19	1	-2	7	5	106	104	4	2	13	5	67	66	2	0	4	6	37	37	2	-2	10	6	30	26	1
4	2	5	198	194	6	-1	7	5	24	21	3	3	13	5	98	99	5	1	4	6	111	111	3	-1	10	6	0	0	1
5	2	5	9	6	7	0	7	5	42	41	1	-4	14	5	44	44	2	2	4	6	0	8	1	0	10	6	92	93	2
6	2	5	84	88	2	1	7	5	102	108	3	-3	14	5	22	20	3	3	4	6	0	8	1	1	10	6	73	78	1
7	2	5	50	47	2	2	7	5	73	68	1	-2	14	5	10	14	9	4	4	6	143	139	4	2	10	6	0	6	1
8	2	5	72	76	3	3	7	5	0	10	1	-1	14	5	7	13	6	5	4	6	33	35	2	3	10	6	0	5	1
-10	3	5	18	23	5	4	7	5	95	91	3	0	14	5	96	89	6	6	4	6	32	31	2	4	10	6	9	5	1
-9	3	5	23	20	3	5	7	5	111	111	6	1	14	5	86	83	1	7	4	6	51	54	2	-6	11	6	49	56	3
-8	3	5	71	71	1	6	7	5	85	83	5	2	14	5	36	38	4	-9	5	6	13	27	13	-5	11	6	11	15	6
-7	3	5	95	47	1	7	7	5	11	11	6	-10	0	6	61	62	2	-8	5	6	13	22	4	-4	11	6	65	64	2
-6	3	5	25	25	2	-9	8	5	14	24	9	-9	0	6	85	86	3	-7	5	6	139	130	1	-3	11	6	60	58	3
-5	3	5	75	74	1	-8	8	5	30	29	2	-8	0	6	180	148	3	-6	5	6	34	35	2	-2	11	6	33	31	2
-4	3	5	38	37	1	-7	8	5	37	38	2	-7	0	6	157	150	2	-5	5	6	131	134	1	-1	11	6	9	8	8
-3	3	5	185	184	2	-6	8	5	41	41	2	-6	0	6	36	34	2	-4	5	6	76	79	1	0	11	6	81	80	1
-2	3	5	90	93	1	-5	8	5	0	13	1	-5	0	6	45	45	3	-3	5	6	66	67	1	1	11	6	0	10	1
-1	3	5	179	182	3	-4	8	5	93	97	3	-4	0	6	116	107	2	-2	5	6	73	64	1	2	11	6	65	65	2
0	3	5	133	134	3	-3	8	5	3	3	3	-3	0	6	375	369	13	-1	5	6	15	21	4	3	11	6	34	38	4
1	3	5	84	75	3	-2	8	5	58	54	2	-2	0	6	163	159	2	0	5	6	101	96	2	4	11	6	0	0	1
2	3	5	90	91	6	-1	8	5	57	58	5	-1	0	6	111	112	1	1	5	6	126	131	1	-5	12	6	50	52	2
3	3	5	87	85	2	0	8	5	33	30	2	0	8	6	51	52	1	2	5	6	42	43	1	-4	12	6	31	31	2
4	3	5	113	112	5	1	8	5	10	14	5	1	8	6	36	36	1	3	5	6	166	160	7	-3	12	6	5	6	5
5	3	5	28	26	2	2	8	5	86	83	1	2	8	6	83	85	1	4	5	6	60	59	1	-2	12	6	7	11	7
6	3	5	62	59	3	3	8	5	141	143	2	3	8	6	194	194	8	5	5	6	41	42	2	-1	12	6	33	31	2
7	3	5	26	22	2	4	8	5	27	23	2	4	8	6	24	22	2	6	5	6	29	30	3	0	12	6	31	35	2
8	3	5	38	37	3	5	8	5	74	77	2	5	8	6	73	73	1	7	5	6	58	61	1	1	12	6	8	4	8
-10	4	5	13	2	8	6	8	5	12	14	8	6	8	6	94	94	2	-8	6	6	102	105	1	2	12	6	7	3	7
-9	4	5	8	10	7	7	8	5	20	24	5	7	8	6	34	33	2	-7	6	6	80	73	1	3	12	6	32	30	2
-8	4	5	22	17	7	-8	9	5	13	11	4	-																	

Table B-4

Continued.

h	k	l	10Fo	10Fc	10s	h	k	l	10Fo	10Fc	10s	h	k	l	10Fo	10Fc	10s	h	k	l	10Fo	10Fc	10s	h	k	l	10Fo	10Fc	10s	
-2	2	7	41	37	1	5	5	7	77	74	1	-2	10	7	33	33	4	-5	3	8	3	0	3	-1	8	8	44	50	2	
-1	2	7	26	24	2	-7	6	7	9	10	9	-1	10	7	53	61	2	-4	3	8	0	2	1	0	8	8	84	80	2	
0	2	7	17	5	4	-6	6	7	15	9	3	0	10	7	9	7	9	-3	3	8	40	47	4	1	8	8	33	34	2	
1	2	7	48	87	2	-5	6	7	84	89	3	1	10	7	102	107	1	-2	3	8	108	106	2	2	8	8	85	83	2	
2	2	7	55	54	1	-4	6	7	0	7	1	2	10	7	11	22	7	-1	3	8	7	11	7	-4	8	8	26	26	4	
3	2	7	92	88	2	-3	6	7	114	112	1	3	10	7	85	53	1	0	3	8	93	90	2	-3	8	8	27	31	3	
4	2	7	94	89	1	-2	6	7	34	38	4	-4	11	7	0	11	1	1	3	8	127	125	1	-2	8	8	9	23	8	
5	2	7	3	1	3	-1	6	7	24	26	2	-3	11	7	0	4	1	2	3	8	16	14	9	-1	9	8	28	26	3	
6	2	7	12	7	3	0	6	7	34	31	2	-2	11	7	37	37	2	3	3	8	72	70	8	0	9	8	6	1	6	
-8	3	7	38	45	4	1	6	7	0	8	1	-1	11	7	9	13	8	4	3	8	0	2	1	1	9	8	0	5	1	
-7	3	7	83	78	1	2	6	7	47	41	2	0	11	7	41	34	7	-6	4	8	60	59	2	-5	1	9	4	0	4	
-6	3	7	71	67	3	3	6	7	59	60	2	1	11	7	0	14	1	-5	4	8	22	22	4	-4	1	9	50	50	2	
-5	3	7	217	212	5	4	6	7	11	12	7	-2	12	7	69	69	2	-4	4	8	5	11	5	-3	1	9	49	48	2	
-4	3	7	86	85	1	5	6	7	38	39	2	-1	12	7	14	13	8	-3	4	8	8	11	8	-2	1	9	95	93	1	
-3	3	7	91	90	1	-6	7	7	7	0	6	-7	0	8	127	128	2	-2	4	8	41	32	2	-1	1	9	9	15	8	
-2	3	7	107	104	1	-5	7	7	0	1	1	-6	0	8	132	130	2	-1	4	8	92	84	1	0	1	9	94	96	1	
-1	3	7	4	4	4	-4	7	7	33	34	1	-5	0	8	199	197	5	0	4	8	19	20	4	1	1	9	9	14	8	
0	3	7	46	39	2	-3	7	7	28	29	3	-4	0	8	142	140	2	1	4	8	19	18	12	2	1	8	0	4	1	
1	3	7	5	8	4	-2	7	7	41	38	2	-3	0	8	58	55	1	2	4	8	36	34	2	-5	2	9	90	84	2	
2	3	7	107	109	2	-1	7	7	87	89	1	-2	0	8	98	99	1	3	4	8	90	88	1	-4	2	9	0	5	1	
3	3	7	13	11	5	0	7	7	33	28	1	-1	8	8	158	154	4	4	4	8	85	84	4	-3	2	9	12	20	6	
4	3	7	94	92	1	1	7	7	64	67	1	0	0	8	264	264	1	-5	5	8	9	4	9	-2	2	9	20	24	6	
5	3	7	7	18	6	2	7	7	10	4	9	1	0	8	195	195	1	-4	5	8	9	16	9	-1	2	9	50	51	3	
6	3	7	11	12	5	3	7	7	15	17	5	2	0	8	210	207	1	-3	5	8	31	28	2	0	2	9	48	47	2	
-7	4	7	41	42	3	4	7	7	49	44	2	1	8	8	104	108	3	-2	5	8	104	103	1	1	2	9	24	24	2	
-6	4	7	88	88	1	5	7	7	13	24	4	4	8	8	50	52	2	-1	5	8	73	68	1	2	2	9	14	23	4	
-5	4	7	56	55	1	-6	8	7	10	16	10	-7	1	8	15	19	6	0	5	8	85	86	1	-4	3	9	14	17	6	
-4	4	7	75	73	1	-5	8	7	92	95	1	-6	1	8	133	136	2	1	5	8	58	57	2	-1	3	9	30	35	2	
-3	4	7	0	0	1	-4	8	7	33	35	3	-5	1	8	43	42	6	2	5	8	40	42	2	-2	3	9	119	118	1	
-2	4	7	15	11	4	-3	8	7	20	27	4	-4	1	8	43	37	1	3	5	8	5	11	5	-1	3	9	92	94	1	
-1	4	7	7	15	6	-2	8	7	18	32	5	-3	1	8	11	12	7	-5	6	8	15	25	8	0	3	9	46	43	2	
0	4	7	40	39	1	-1	8	7	31	42	3	-2	1	8	44	43	1	-4	6	8	17	22	4	1	3	9	71	75	1	
1	4	7	69	65	1	0	8	7	54	58	2	-1	1	8	21	22	3	-3	6	8	94	98	1	2	2	9	14	15	7	
2	4	7	149	140	2	1	8	7	99	95	3	0	1	8	14	13	7	-2	6	8	40	43	2	-4	4	9	41	39	3	
3	4	7	55	82	3	2	8	7	43	48	2	1	1	8	36	37	3	-1	6	8	94	96	2	-3	4	9	0	4	1	
4	4	7	39	37	2	3	8	7	51	51	2	2	1	8	49	46	2	0	6	8	64	60	1	-2	4	9	4	3	4	
5	4	7	25	31	3	4	8	7	68	63	1	3	1	8	32	38	2	1	6	8	47	53	2	-1	4	9	28	27	3	
6	4	7	14	19	4	-6	9	7	8	9	4	4	1	8	19	15	3	2	6	8	10	4	7	0	4	9	0	14	1	
-7	5	7	52	52	2	-5	9	7	22	15	3	-6	2	8	108	111	6	3	6	8	0	3	1	1	4	9	6	7	6	
-8	5	7	31	38	3	-4	9	7	0	6	1	-5	2	8	10	17	9	-5	7	8	6	18	6	-4	5	9	50	51	2	
-5	5	7	96	92	1	-3	9	7	96	97	2	-4	2	8	138	135	3	-4	7	8	40	44	2	-3	5	9	19	24	5	
-4	5	7	19	17	3	-2	9	7	31	30	2	-3	2	8	107	103	1	-3	7	8	48	49	3	-2	5	9	40	43	3	
-3	5	7	68	70	2	-1	9	7	49	57	3	-2	2	8	14	6	9	-2	7	8	44	52	2	-1	5	9	33	35	3	
-2	5	7	73	70	1	0	9	7	67	64	1	-1	2	8	18	12	6	-1	7	8	6	0	5	0	5	9	43	49	3	
-1	5	7	8	3	8	1	9	7	13	29	10	8	2	8	10	6	9	0	7	8	78	83	5	-3	6	9	29	29	4	
0	5	7	48	45	2	2	9	7	103	103	1	1	2	8	63	41	2	1	7	8	14	20	5	-2	6	9	38	32	2	
1	5	7	24	15	2	3	9	7	67	68	1	2	2	8	65	68	3	2	7	8	131	134	4	-1	6	9	5	5	4	
2	5	7	139	132	3	-9	10	7	0	2	1	3	2	8	52	53	2	-4	8	8	71	81	2	0	6	9	64	68	2	
3	5	7	69	72	1	-4	10	7	70	73	2	4	2	8	183	182	1	-5	8	8	0	21	1							
4	5	7	49	51	1	-3	10	7	51	55	2	-4	3	8	68	65	2	-2	8	8	54	58	1							

APPENDIX C**CRYSTALLOGRAPHY DATA FOR 2**

Table C-1**Bond lengths [Å] and angles [°] for 2.**

C1-C(14)	1.731(4)	N-C(21)	1.386(4)
N-C(3)	1.446(4)	N-H(1N)	0.82(3)
O(1)-C(1)	1.325(4)	O(1)-C(4)	1.451(5)
C(1)-O(2)	1.203(4)	C(1)-C(2)	1.514(5)
C(2)-O(3)	1.400(4)	C(2)-C(3)	1.545(4)
C(2)-H(2)	0.92(3)	O(3)-C(5)	1.417(4)
C(3)-C(11)	1.514(4)	C(3)-H(3)	1.03(3)
O(4)-C(22)	1.368(4)	O(4)-C(6)	1.421(5)
C(4)-H(4A)	0.9600	C(4)-H(4B)	0.9600
C(4)-H(4C)	0.9600	C(5)-H(5A)	0.9600
C(5)-H(5B)	0.9600	C(5)-H(5C)	0.9600
C(6)-H(6A)	1.04(9)	C(6)-H(6C)	0.99(5)
C(6)-H(6B)	1.16(10)	C(11)-C(12)	1.375(5)
C(11)-C(16)	1.388(4)	C(12)-C(13)	1.377(5)
C(12)-H(12)	0.90(4)	C(13)-C(14)	1.375(6)
C(13)-H(13)	1.07(4)	C(14)-C(15)	1.356(6)
C(15)-C(16)	1.380(6)	C(15)-H(15)	0.94(5)
C(16)-H(16)	0.91(3)	C(21)-C(26)	1.391(5)
C(21)-C(22)	1.404(5)	C(22)-C(23)	1.389(6)
C(23)-C(24)	1.385(7)	C(23)-H(23A)	0.9300
C(24)-C(25)	1.350(7)	C(24)-H(24)	1.11(4)
C(25)-C(26)	1.396(6)	C(25)-H(25)	0.90(4)
C(26)-H(26)	0.95(4)		
C(21)-N-C(3)	120.5(3)	C(21)-N-H(1N)	114(2)
C(3)-N-H(1N)	113(2)	C(1)-O(1)-C(4)	117.2(3)
O(2)-C(1)-O(1)	123.7(3)	O(2)-C(1)-C(2)	124.4(3)
O(1)-C(1)-C(2)	111.9(2)	O(3)-C(2)-C(1)	111.9(3)
O(3)-C(2)-C(3)	106.0(2)	C(1)-C(2)-C(3)	110.4(2)
O(3)-C(2)-H(2)	109.7(17)	C(1)-C(2)-H(2)	110.5(18)
C(3)-C(2)-H(2)	108.1(17)	C(2)-O(3)-C(5)	113.0(3)
N-C(3)-C(11)	112.9(2)	N-C(3)-C(2)	109.3(2)
C(11)-C(3)-C(2)	111.9(2)	N-C(3)-H(3)	109.8(15)
C(11)-C(3)-H(3)	109.1(15)	C(2)-C(3)-H(3)	103.5(15)
C(22)-O(4)-C(6)	118.6(4)	O(1)-C(4)-H(4A)	109.5
O(1)-C(4)-H(4B)	109.5	H(4A)-C(4)-H(4B)	109.5
O(1)-C(4)-H(4C)	109.5	H(4A)-C(4)-H(4C)	109.5
H(4B)-C(4)-H(4C)	109.5	O(3)-C(5)-H(5A)	109.5
O(3)-C(5)-H(5B)	109.5	H(5A)-C(5)-H(5B)	109.5
O(3)-C(5)-H(5C)	109.5	H(5A)-C(5)-H(5C)	109.5
H(5B)-C(5)-H(5C)	109.5	O(4)-C(6)-H(6A)	108(4)
O(4)-C(6)-H(6C)	107(3)	H(6A)-C(6)-H(6C)	116(6)
O(4)-C(6)-H(6B)	106(4)	H(6A)-C(6)-H(6B)	115(7)
H(6C)-C(6)-H(6B)	105(5)	C(12)-C(11)-C(16)	117.5(3)
C(12)-C(11)-C(3)	119.1(3)	C(16)-C(11)-C(3)	123.4(3)
C(11)-C(12)-C(13)	122.2(4)	C(11)-C(12)-H(12)	119(2)
C(13)-C(12)-H(12)	119(2)	C(14)-C(13)-C(12)	119.0(4)
C(14)-C(13)-H(13)	121(2)	C(12)-C(13)-H(13)	120(2)
C(15)-C(14)-C(13)	120.1(3)	C(15)-C(14)-C1	120.3(3)
C(13)-C(14)-C1	119.6(3)	C(14)-C(15)-C(16)	120.8(4)
C(14)-C(15)-H(15)	118(2)	C(16)-C(15)-H(15)	121(2)
C(15)-C(16)-C(11)	120.4(4)	C(15)-C(16)-H(16)	122.6(19)
C(11)-C(16)-H(16)	116(2)	N-C(21)-C(26)	123.2(3)
N-C(21)-C(22)	118.2(3)	C(26)-C(21)-C(22)	118.5(3)
O(4)-C(22)-C(21)	114.5(3)	O(4)-C(22)-C(23)	125.0(3)

Table C-1**Continued.**

C(21) -C(22) -C(23)	120.5(4)	C(24) -C(23) -C(22)	119.6(4)
C(24) -C(23) -H(23A)	120.2	C(22) -C(23) -H(23A)	120.2
C(25) -C(24) -C(23)	120.5(4)	C(25) -C(24) -H(24)	129(2)
C(23) -C(24) -H(24)	111(2)	C(24) -C(25) -C(26)	121.0(5)
C(24) -C(25) -H(25)	124(3)	C(26) -C(25) -H(25)	115(3)
C(25) -C(26) -C(21)	119.9(4)	C(25) -C(26) -H(26)	121(2)
C(21) -C(26) -H(26)	119(2)		

Table C-2

Anisotropic displacement parameters [$\text{\AA}^2 \times 10^3$] for 2. The anisotropic displacement factor exponent takes the form: $-2\pi^2 [(ha^*)^2U_{11} + \dots + 2hka^*b^*U_{12}]$

	U11	U22	U33	U23	U13	U12
C1	139 (1)	123 (1)	127 (1)	67 (1)	39 (1)	61 (1)
H	49 (1)	56 (2)	72 (2)	-2 (1)	13 (1)	-4 (1)
O(1)	73 (1)	69 (1)	56 (1)	13 (1)	1 (1)	-11 (1)
C(1)	51 (2)	51 (2)	59 (2)	8 (2)	12 (2)	1 (1)
O(2)	99 (2)	61 (1)	73 (2)	3 (1)	8 (2)	-8 (1)
C(2)	44 (2)	59 (2)	60 (2)	20 (2)	3 (1)	-2 (1)
O(3)	56 (1)	80 (1)	71 (1)	29 (1)	0 (1)	8 (1)
C(3)	43 (1)	61 (2)	54 (2)	3 (2)	-2 (1)	-3 (1)
O(4)	65 (1)	84 (2)	108 (2)	12 (2)	23 (1)	-18 (1)
C(4)	105 (3)	104 (3)	59 (2)	6 (2)	-1 (2)	-20 (2)
C(5)	62 (2)	103 (3)	111 (3)	36 (3)	-5 (2)	24 (2)
C(6)	92 (3)	114 (4)	130 (5)	18 (3)	18 (3)	-42 (3)
C(11)	44 (1)	55 (2)	54 (2)	1 (1)	-1 (1)	1 (1)
C(12)	64 (2)	63 (2)	69 (2)	10 (2)	-7 (2)	-4 (2)
C(13)	85 (3)	67 (2)	90 (3)	15 (2)	11 (3)	1 (2)
C(14)	84 (3)	73 (2)	68 (2)	20 (2)	21 (2)	24 (2)
C(15)	68 (2)	110 (3)	58 (2)	5 (2)	-3 (2)	36 (2)
C(16)	51 (2)	75 (2)	63 (2)	-2 (2)	-4 (2)	6 (2)
C(21)	47 (2)	78 (2)	47 (2)	4 (2)	4 (2)	6 (1)
C(22)	51 (2)	91 (2)	62 (2)	17 (2)	10 (2)	3 (2)
C(23)	68 (2)	127 (4)	80 (3)	37 (3)	24 (2)	9 (2)
C(24)	87 (3)	145 (5)	66 (2)	18 (3)	28 (2)	33 (3)
C(25)	87 (3)	115 (3)	59 (2)	-9 (3)	1 (2)	35 (3)
C(26)	62 (2)	87 (2)	54 (2)	-1 (2)	-2 (2)	11 (2)

Table C-3

Hydrogen coordinates ($\times 10^4$) and isotropic displacement parameters ($\text{\AA}^2 \times 10^3$)
for 2.

	x	y	z	U(eq)
H(1N)	7010(20)	987(15)	6010(40)	43(8)
H(2)	9420(20)	1703(14)	4750(40)	43(7)
H(3)	8130(20)	2011(14)	6840(40)	49(7)
H(4A)	8220	1425	-386	134
H(4B)	7290	1027	647	134
H(4C)	8482	688	277	134
H(5A)	10464	406	6999	138
H(5B)	10822	1070	6030	138
H(5C)	10309	448	5043	138
H(6A)	4840(70)	-520(40)	6650(130)	200(30)
H(6C)	3790(40)	100(20)	6890(70)	97(14)
H(12)	8860(30)	3005(18)	5320(50)	71(11)
H(13)	8540(40)	4030(20)	3850(60)	98(13)
H(15)	5830(40)	3020(19)	1680(60)	94(12)
H(16)	6130(20)	2096(14)	3550(40)	42(7)
H(23A)	3748	924	8964	110
H(24)	3410(30)	1970(20)	10070(60)	89(12)
H(25)	4920(40)	2830(20)	9140(60)	93(14)
H(26)	6420(30)	2577(17)	7450(40)	62(9)
H(6B)	4490(60)	-120(40)	8700(130)	180(30)

Table C-4

Observed and calculated structure factors for 2.

h	k	l	10Fo	10Fc	10a	h	k	l	10Fo	10Fc	10a	h	k	l	10Fo	10Fc	10a	h	k	l	10Fo	10Fc	10a						
0	0	-8	144	137	1	0	2	-4	25	31	4	2	3	-5	154	155	2	2	15	-5	41	41	3	0	0	-4	104	104	2
2	0	-8	89	87	2	1	3	-6	62	63	2	3	3	-8	50	53	2	3	15	-5	19	21	5	9	0	-4	29	25	3
1	1	-8	28	23	2	2	3	-6	155	149	2	4	3	-8	104	110	2	1	16	-5	10	27	6	1	9	-4	114	112	2
2	1	-8	43	43	2	3	3	-6	102	106	2	5	3	-8	21	20	4	0	0	-4	291	321	6	2	9	-4	50	51	2
3	1	-8	0	10	1	4	3	-6	210	204	2	6	3	-8	148	161	3	2	0	-4	266	272	6	3	9	-4	124	130	2
0	2	-8	24	26	4	5	3	-6	123	123	2	7	3	-8	80	95	1	4	0	-4	47	48	2	4	9	-4	141	154	2
1	2	-8	103	104	2	6	3	-6	39	39	2	8	3	-8	45	40	2	6	0	-4	174	184	3	5	9	-4	119	125	2
2	2	-8	65	67	2	7	3	-6	46	52	2	9	3	-8	15	29	6	8	0	-4	199	193	3	6	9	-4	155	152	2
3	2	-8	44	44	2	0	4	-6	84	69	2	1	4	-5	132	130	2	10	0	-4	51	54	2	7	9	-4	43	40	2
1	3	-8	9	2	7	1	4	-6	23	20	4	2	4	-5	100	109	2	1	1	-4	274	283	6	8	9	-4	23	20	3
2	3	-8	47	43	2	2	4	-6	127	120	2	3	4	-5	237	232	4	2	1	-4	146	167	3	0	10	-4	143	145	2
0	4	-8	42	45	2	2	4	-6	58	58	2	4	4	-5	144	140	2	3	1	-4	70	66	1	1	10	-4	102	102	2
1	4	-8	26	32	4	4	4	-6	189	112	2	5	4	-5	39	37	2	4	1	-4	242	235	5	2	10	-4	42	46	2
2	4	-8	18	27	7	8	4	-6	23	24	4	6	4	-5	36	41	3	5	1	-4	88	89	2	3	10	-4	67	79	2
1	5	-8	15	7	5	6	4	-6	109	104	2	7	4	-5	9	18	8	6	2	-4	62	63	2	4	10	-4	125	131	2
0	6	-8	61	58	2	7	4	-6	75	78	2	8	4	-5	32	25	2	7	1	-4	30	36	2	5	10	-4	91	85	2
2	0	-7	206	205	2	1	5	-5	79	79	2	9	4	-5	40	39	2	8	1	-4	129	133	3	6	10	-4	182	175	2
4	0	-7	80	79	1	2	5	-4	107	111	2	0	5	-5	183	194	4	9	1	-4	84	49	1	7	10	-4	88	85	1
6	0	-7	39	38	4	3	5	-4	82	82	1	1	5	-5	109	109	3	10	1	-4	32	33	2	8	10	-4	77	76	2
0	1	-7	163	161	2	4	5	-4	81	80	1	2	5	-5	145	158	2	11	1	-4	321	331	8	9	11	-4	186	188	4
1	1	-7	149	148	2	5	5	-6	69	78	1	3	5	-5	29	36	2	1	2	-4	200	196	3	2	11	-4	157	162	2
2	1	-7	34	38	6	6	5	-6	43	43	2	4	5	-5	149	151	2	2	2	-4	235	240	5	3	11	-4	184	207	3
3	1	-7	30	33	3	7	5	-6	74	89	2	5	5	-5	104	104	2	3	2	-4	288	281	5	4	11	-4	43	41	2
4	1	-7	111	107	2	0	6	-6	218	211	3	6	5	-5	173	180	3	4	2	-4	172	163	3	5	11	-4	41	34	2
5	1	-7	69	71	2	1	6	-6	43	35	2	7	5	-5	9	17	9	5	2	-4	37	48	2	6	11	-4	25	21	3
6	1	-7	8	22	7	2	6	-6	105	108	2	8	5	-5	127	130	2	6	2	-4	33	34	2	7	11	-4	17	15	6
1	2	-7	100	98	1	3	6	-6	26	22	3	1	6	-5	182	184	1	7	2	-4	109	114	2	8	12	-4	98	106	1
2	2	-7	66	63	1	4	6	-6	40	52	2	2	6	-5	184	186	4	8	2	-4	36	44	2	9	12	-4	156	173	3
3	2	-7	54	55	1	5	6	-6	48	43	2	3	6	-5	184	189	2	9	2	-4	185	180	2	2	12	-4	36	40	3
4	2	-7	72	76	2	6	6	-6	87	98	2	4	6	-5	79	74	1	10	2	-4	8	11	6	3	12	-4	86	94	2
5	2	-7	99	98	2	1	7	-6	42	42	3	5	6	-5	269	270	3	1	3	-4	213	223	4	4	12	-4	67	75	2
6	2	-7	30	36	3	2	7	-6	70	80	3	6	6	-5	184	183	2	2	3	-4	225	221	3	5	12	-4	38	41	2
0	3	-7	35	33	2	3	7	-6	41	34	2	7	6	-5	40	51	2	3	3	-4	264	273	5	6	12	-4	88	91	2
1	3	-7	73	72	1	4	7	-6	64	59	1	0	6	-5	25	32	3	4	3	-4	132	128	2	7	12	-4	23	22	3
2	3	-7	16	15	5	5	7	-6	62	63	1	0	7	-5	184	149	2	5	2	-4	110	110	2	2	13	-4	39	39	2
3	3	-7	88	83	1	6	7	-6	33	34	3	1	7	-5	19	21	4	6	3	-4	103	115	2	3	13	-4	77	84	2
4	3	-7	26	30	4	0	8	-6	97	94	2	2	7	-5	131	129	2	7	3	-4	91	93	1	4	13	-4	87	93	1
5	3	-7	27	33	4	1	8	-6	13	9	6	3	7	-5	86	80	1	8	3	-4	27	24	3	5	13	-4	8	6	7
1	4	-7	90	81	1	2	8	-6	51	45	2	4	7	-5	123	121	2	9	3	-4	70	73	1	6	13	-4	107	113	2
2	4	-7	174	173	2	3	8	-6	111	104	1	5	7	-5	29	24	3	10	3	-4	60	64	2	7	13	-4	34	36	3
3	4	-7	64	68	1	4	8	-6	106	106	2	0	8	-4	170	177	2	0	4	-4	215	209	3	8	14	-4	85	82	1
4	4	-7	49	43	2	5	8	-6	98	88	2	7	7	-5	83	99	1	1	4	-4	131	140	2	9	14	-4	108	104	2
5	4	-7	31	31	3	1	9	-6	47	53	2	8	7	-5	40	45	3	2	4	-4	123	125	2	2	14	-4	78	74	1
6	4	-7	94	81	1	2	9	-6	47	53	2	1	8	-5	97	95	2	3	4	-4	177	189	3	3	14	-4	64	68	1
1	5	-7	134	133	2	3	9	-6	91	84	1	2	8	-5	55	56	2	4	4	-4	216	219	5	4	14	-4	111	108	2
2	5	-7	40	47	2	4	9	-6	11	19	11	3	8	-5	84	98	1	5	4	-4	158	177	3	5	14	-4	33	34	3
3	5	-7	14	18	9	5	9	-6	6	6	6	4	8	-5	78	78	1	6	4	-4	126	139	2	6	14	-4	101	95	2
4	5	-7	31	39	4	0	10	-6	185	173	2	5	8	-5	34	37	3	7	4	-4	165	168	3	7	14	-4	74	74	1
5	5	-7	25	25	4	1	10	-6	82	87	1	6	8	-5	37	33	2	8	4	-4	129	136	2	2	15	-4	71	70	1
1	6	-7	105	105	2	2	10	-6	89	70	1	7	8	-5	41	37	3	9	4	-4	85	84	1	3	15	-4	98	94	2
2	6	-7	35	34	2	3	10	-6	39	28	2	0	9	-5	64	43	2	10	4	-4	47	49	2	4	15	-4	79	82	2
3	6	-7	96	93	2	4	10	-6	74	70	2	1	9	-5	62	64	2	1	5	-4	208	198	3	5	15	-4	87	81	2
4	6	-7	47	45	2	1	11	-6	62	47	2	2	9	-5	114	114	2	2	5	-4	151	146	3	0	16	-4	51	50	2
0	7	-7	128	129	2	2	11	-6	66	68	2	3	9	-5	126	119	2	3	5	-4	0	3	1	1	16	-4	72	73	2
1	7	-7	29	32	4	3	11	-6	96	104	2	4	9	-5	120	122	3	4	5	-4	127	130	2	2	16	-4	49	37	2
2	7	-7	36	34	3	4	11	-6	48	52	3	5	9	-5	74	78	1	5	5	-4	13	12	9	3	16	-4	40	42	3
3	7	-7	57	57	2	0	12	-6	56	70	2	6	9	-5	141	143	2	6	5	-4	126	133	2	4	16	-4	30	32	3
4	7	-7	51	54	2	1	12	-6	28	30	4	7	9	-5	48	49	2	7	5	-4	134	135	2	1	17	-4	26	28	4
1	8	-7	95	81	2	2	12	-6	35	38	3	1	10	-5	65	63	2	8	5	-4	91	90	1	2	17	-4	144	144	2
2	8	-7	45	26	2	3	12	-6	43	50	3	2	10	-5	8	25	7	9	5	-4	22	22	4	3	17	-4	43	43	2
3	8	-7	47	43	2	1	13	-6	48	58																			

Table C-4

Continued.

h	k	l	10Po	10Pc	10a	h	k	l	10Po	10Pc	10a	h	k	l	10Po	10Pc	10a	h	k	l	10Po	10Pc	10a	h	k	l	10Po	10Pc	10a
10	2	-3	50	50	1	2	11	-3	124	122	2	2	3	-2	700	714	6	1	11	-2	127	115	2	2	2	-1	244	237	5
11	2	-3	49	48	2	3	11	-3	94	82	1	3	1	-2	131	134	2	1	2	-1	75	77	2	1	2	-1	953	907	6
0	3	-3	330	329	6	4	11	-3	49	50	2	4	1	-2	535	525	6	3	11	-2	132	131	2	4	2	-1	172	172	3
1	3	-3	212	214	4	5	11	-3	197	197	3	5	1	-2	129	121	3	4	11	-2	78	74	1	5	2	-1	552	518	6
2	3	-3	104	108	2	6	11	-3	109	99	2	6	3	-2	273	274	5	5	11	-2	163	159	3	6	2	-1	126	109	3
3	3	-3	334	330	6	7	11	-3	115	107	2	7	3	-2	150	149	3	6	11	-2	103	105	1	7	2	-1	150	153	3
4	3	-3	234	231	4	8	11	-3	15	13	5	8	3	-2	194	193	4	7	11	-2	83	82	1	8	2	-1	151	151	2
5	3	-3	180	138	3	9	11	-3	27	29	3	9	3	-2	169	166	3	8	11	-2	87	83	1	9	2	-1	131	126	2
6	3	-3	289	241	5	1	12	-3	210	204	4	10	3	-2	79	81	1	9	11	-2	0	6	1	10	2	-1	120	119	3
7	3	-3	118	116	2	2	12	-3	155	146	2	11	3	-2	57	53	2	11	2	-2	167	170	3	11	2	-1	70	70	2
8	3	-3	32	31	3	3	12	-3	258	245	4	0	4	-2	706	674	7	1	12	-2	111	109	2	12	2	-1	0	15	1
9	3	-3	63	60	2	4	12	-3	190	195	3	1	4	-2	804	779	7	2	12	-2	47	48	2	0	3	-1	247	260	4
10	3	-3	23	23	4	5	12	-3	89	87	1	2	4	-2	204	201	4	3	12	-2	62	55	2	1	3	-1	532	540	6
11	3	-3	46	45	2	6	12	-3	54	53	1	3	4	-2	200	200	6	4	12	-2	131	133	2	2	3	-1	1127	1110	6
1	4	-3	89	85	1	7	12	-3	20	22	2	4	4	-2	199	185	4	5	12	-2	97	93	2	3	3	-1	367	377	6
2	4	-3	72	67	1	8	12	-3	46	43	2	5	4	-2	246	230	6	6	12	-2	53	52	2	4	3	-1	122	124	2
3	4	-3	545	532	6	9	12	-3	182	177	4	6	4	-2	132	125	2	7	12	-2	39	34	2	5	3	-1	167	160	3
4	4	-3	244	240	4	1	13	-3	127	132	2	7	4	-2	248	231	4	8	12	-2	73	79	2	6	3	-1	217	216	3
5	4	-3	190	195	3	2	13	-3	53	54	2	8	4	-2	189	185	2	9	12	-2	60	55	2	7	3	-1	159	161	3
6	4	-3	146	136	2	3	13	-3	43	42	2	9	4	-2	184	149	3	1	13	-2	118	124	2	8	3	-1	63	62	1
7	4	-3	37	40	2	4	13	-3	198	193	3	10	4	-2	69	45	2	2	13	-2	149	135	2	9	3	-1	114	113	2
8	4	-3	116	112	2	5	13	-3	90	91	1	11	4	-2	55	52	2	3	13	-2	113	119	2	10	3	-1	96	92	1
9	4	-3	50	47	2	6	13	-3	65	62	1	1	5	-2	311	311	7	4	13	-2	92	88	1	11	3	-1	72	71	2
10	4	-3	64	62	2	7	13	-3	89	78	2	2	5	-2	90	88	2	5	13	-2	149	146	3	12	3	-1	26	31	3
11	4	-3	15	16	6	8	13	-3	54	46	2	3	5	-2	112	113	2	6	13	-2	169	158	2	1	4	-1	128	123	2
0	5	-3	471	452	6	1	14	-3	41	36	2	4	5	-2	139	144	2	7	13	-2	94	84	1	2	4	-1	350	354	6
1	5	-3	235	225	4	2	14	-3	57	51	2	5	5	-2	116	113	2	8	13	-2	55	53	2	3	4	-1	287	293	6
2	5	-3	439	422	6	3	14	-3	48	48	2	6	5	-2	184	187	3	9	14	-2	283	262	4	4	4	-1	301	317	6
3	5	-3	264	260	6	4	14	-3	20	31	5	7	5	-3	138	126	2	1	14	-2	45	44	2	5	4	-1	540	539	6
4	5	-3	319	217	4	5	14	-3	95	98	1	8	5	-2	178	168	3	2	14	-2	155	140	3	6	4	-1	179	183	3
5	5	-3	158	148	3	6	14	-3	107	103	2	9	5	-2	53	52	2	3	14	-2	24	30	3	7	4	-1	64	63	1
6	5	-3	81	78	2	7	14	-3	71	73	2	10	5	-3	107	110	2	4	14	-2	67	72	1	8	4	-1	232	222	4
7	5	-3	111	105	2	8	14	-3	56	55	2	11	5	-2	44	40	2	5	14	-2	50	51	2	9	4	-1	83	81	1
8	5	-3	100	98	3	9	14	-3	102	100	2	0	6	-2	98	103	2	6	14	-2	172	168	2	10	4	-1	72	70	2
9	5	-3	97	93	1	1	15	-3	15	14	7	1	6	-2	586	610	7	7	14	-2	50	46	2	11	4	-1	45	49	2
10	5	-3	86	84	2	2	15	-3	110	101	1	2	6	-2	121	121	2	8	14	-2	10	13	9	12	4	-1	18	25	5
1	6	-3	88	84	1	4	15	-3	82	78	1	3	6	-2	109	90	2	1	15	-2	103	105	2	0	5	-1	126	132	2
2	6	-3	486	388	6	5	15	-3	34	36	3	4	6	-2	84	55	1	2	15	-2	36	34	2	1	5	-1	100	97	2
3	6	-3	214	217	4	6	15	-3	69	69	2	5	6	-2	183	157	3	3	15	-2	133	129	3	2	5	-1	452	464	6
4	6	-3	113	117	2	1	16	-3	47	68	1	6	6	-2	89	73	2	4	15	-2	104	106	1	3	5	-1	195	195	3
5	6	-3	13	15	11	2	16	-3	58	63	2	7	6	-2	113	104	2	5	15	-2	94	86	1	4	5	-1	177	181	3
6	6	-3	88	88	2	3	16	-3	127	125	2	8	6	-2	136	119	2	6	15	-2	56	55	2	5	5	-1	277	285	5
7	6	-3	77	78	1	4	16	-3	52	52	2	9	6	-3	282	193	2	7	15	-2	0	13	1	6	5	-1	119	114	2
8	6	-3	98	93	2	5	16	-3	16	17	5	10	6	-2	75	71	1	8	16	-2	63	70	2	7	5	-1	98	93	1
9	6	-3	76	69	1	6	17	-3	199	195	2	11	6	-2	33	28	3	1	16	-2	106	99	1	8	5	-1	131	123	2
10	6	-3	82	75	2	1	17	-3	81	75	2	1	7	-2	301	309	7	2	16	-2	89	82	1	9	5	-1	64	67	1
1	7	-3	293	242	4	2	17	-3	88	84	2	2	7	-2	324	315	6	3	16	-2	89	88	1	10	5	-1	141	134	2
2	7	-3	440	456	5	3	17	-3	26	24	4	3	7	-2	87	198	3	4	16	-2	39	41	2	11	5	-1	75	65	2
3	7	-3	234	287	4	4	17	-3	52	47	2	4	7	-2	84	81	2	5	16	-2	44	46	2	1	6	-1	63	65	2
4	7	-3	126	134	3	5	17	-3	43	42	2	5	7	-2	124	129	2	6	16	-2	82	82	2	2	6	-1	284	262	4
5	7	-3	156	144	3	6	17	-3	31	46	4	6	7	-2	109	99	2	3	17	-2	69	46	2	3	6	-1	108	101	2
6	7	-3	209	196	4	7	17	-3	89	86	2	7	7	-3	48	39	2	4	17	-2	9	17	8	4	6	-1	215	216	4
7	7	-3	101	92	2	8	17	-3	109	102	1	8	7	-2	27	21	3	5	17	-2	21	23	3	5	6	-1	227	243	5
8	7	-3	132	120	2	9	17	-3	85	81	2	9	7	-2	89	44	2	6	17	-2	69	70	2	6	6	-1	150	146	3
9	7	-3	119	101	2	1	18	-3	91	87	2	10	7	-2	58	51	2	7	17	-2	80	76	2	7	6	-1	166	142	2
10	7	-3	79	75	1	2	18	-3	16	16	7	11	7	-2	66	66	2	8	17	-2	24	24	4	8	6	-1	46	45	2
1	8	-3	26	22	4	0	18	-3	775	799	6	0	8	-2	462	462	6	9	18	-2	37	33	2	9	6	-1	30	26	2
2	8	-3	389	314	6	1	18	-3	448	484	4	1	8	-2	283	192	3	1	18	-2	64	61	2	10	6	-1	142	141	2
3	8	-3	221	233	3	2	18	-3	252	158	3	2	8	-2	133	130	3	2	18	-2	11	13	10	11	6	-1	16	15	6
4	8	-3	177	178	3	3</																							

Table C-4

Continued.

h k l 10Po 10Po 10s				h k l 10Po 10Po 10s				h k l 10Po 10Po 10s				h k l 10Po 10Po 10s				h k l 10Po 10Po 10s			
6 9 -1	76	75	1	3 20 -1	6	5	6	6 7 0	45	44	1	6 15 0	46	52	1	8 4 1	220	218	4
7 9 -1	114	112	2	0 21 -1	23	31	3	7 7 0	144	135	5	7 15 0	60	69	1	9 4 1	86	89	1
8 9 -1	0	15	1	2 0 0	363	308	3	8 7 0	13	13	4	8 15 0	60	65	1	10 4 1	72	72	1
9 9 -1	70	72	1	4 0 0	330	329	4	9 7 0	76	78	1	9 15 0	76	71	2	11 4 1	53	51	2
10 9 -1	11	20	11	6 0 0	393	413	7	10 7 0	5	4	5	0 14 0	104	85	1	12 4 1	20	25	4
1 10 -1	169	157	3	8 0 0	247	252	3	11 7 0	58	55	1	1 16 0	193	196	1	0 5 1	118	124	2
2 10 -1	343	336	6	10 0 0	69	66	1	12 7 0	5	17	5	2 16 0	118	106	1	1 5 1	76	75	1
3 10 -1	101	95	2	12 0 0	69	64	1	0 8 0	150	155	2	3 16 0	30	35	3	2 5 1	448	471	6
4 10 -1	171	169	3	1 1 0	74	76	1	1 8 0	208	192	2	4 16 0	123	116	1	3 5 1	181	195	3
5 10 -1	45	49	1	2 1 0	175	208	3	2 8 0	43	61	1	5 16 0	28	25	2	4 5 1	173	182	3
6 10 -1	22	17	2	3 1 0	1233	1205	5	3 8 0	149	172	2	6 16 0	41	43	3	5 5 1	277	371	5
7 10 -1	75	76	1	4 1 0	71	72	1	4 8 0	40	49	1	7 16 0	82	90	1	6 5 1	178	104	2
8 10 -1	162	97	1	5 1 0	201	214	2	5 8 0	170	183	2	8 16 0	0	3	1	7 5 1	99	97	2
9 10 -1	48	46	1	6 1 0	0	5	1	6 8 0	75	83	1	1 17 0	68	64	4	8 5 1	129	125	2
10 10 -1	41	45	2	7 1 0	61	55	1	7 8 0	122	134	3	2 17 0	44	46	1	9 5 1	65	66	1
0 11 -1	138	135	2	8 1 0	134	132	1	8 8 0	108	109	1	3 17 0	49	43	1	10 5 1	128	131	2
1 11 -1	30	29	2	9 1 0	3	0	3	9 8 0	90	90	1	4 17 0	110	129	4	11 5 1	63	62	2
2 11 -1	138	130	3	10 1 0	0	4	1	10 8 0	40	47	1	5 17 0	112	107	4	12 5 1	61	62	2
3 11 -1	28	34	2	11 1 0	10	7	5	11 8 0	44	45	3	6 17 0	30	31	2	1 6 1	66	63	1
4 11 -1	85	84	1	12 1 0	71	70	1	1 9 0	185	190	2	7 17 0	78	79	1	2 6 1	254	265	4
5 11 -1	165	158	2	0 2 0	349	350	3	2 9 0	24	27	1	0 18 0	114	131	5	3 6 1	110	112	2
6 11 -1	110	115	1	1 2 0	422	421	5	3 9 0	66	72	1	1 18 0	63	60	1	4 6 1	232	232	5
7 11 -1	68	60	1	2 2 0	399	426	3	4 9 0	101	101	1	2 18 0	112	116	2	5 6 1	240	254	5
8 11 -1	125	122	2	3 2 0	316	329	4	5 9 0	296	293	3	3 18 0	77	85	3	6 6 1	144	145	3
9 11 -1	49	46	2	4 2 0	201	237	6	6 9 0	162	166	2	4 18 0	58	56	1	7 6 1	159	160	3
10 11 -1	30	23	3	5 2 0	70	76	1	7 9 0	70	71	1	5 18 0	18	23	3	8 6 1	41	43	2
1 12 -1	185	183	2	6 2 0	172	178	2	8 9 0	95	95	1	6 18 0	41	44	3	9 6 1	31	26	2
2 12 -1	183	200	3	7 2 0	95	94	1	9 9 0	10	2	5	1 19 0	15	23	4	10 6 1	139	141	2
3 12 -1	194	195	4	8 2 0	188	190	6	10 9 0	67	70	1	2 19 0	94	94	4	11 6 1	0	17	8
4 12 -1	99	99	2	9 2 0	45	41	1	11 9 0	25	23	2	3 19 0	32	26	4	12 6 1	10	23	10
5 12 -1	84	77	1	10 2 0	5	11	5	0 10 0	340	320	4	4 19 0	32	26	2	0 7 1	242	235	4
6 12 -1	93	80	1	11 2 0	86	46	2	1 10 0	365	374	4	5 19 0	15	17	4	1 7 1	264	271	4
7 12 -1	153	139	2	12 2 0	84	85	2	2 10 0	281	265	15	6 20 0	137	140	2	2 7 1	155	145	3
8 12 -1	87	89	1	1 3 0	4	9	3	3 10 0	91	93	2	1 20 0	71	69	1	3 7 1	362	347	6
9 12 -1	34	40	2	2 3 0	440	496	4	4 10 0	195	187	2	2 20 0	36	41	3	4 7 1	183	167	3
0 13 -1	172	169	3	3 3 0	181	104	1	5 10 0	174	181	2	3 20 0	11	19	5	5 7 1	99	105	2
1 13 -1	150	145	3	4 3 0	36	38	1	6 10 0	161	162	2	4 20 0	13	13	5	6 7 1	178	172	3
2 13 -1	124	133	2	5 3 0	114	118	1	7 10 0	179	176	2	1 21 0	8	9	7	7 7 1	45	46	1
3 13 -1	44	48	3	6 3 0	490	526	4	8 10 0	6	12	8	2 21 0	5	1	4	8 7 1	65	63	1
4 13 -1	26	34	2	7 3 0	178	175	3	9 10 0	34	38	1	3 21 0	275	279	6	9 7 1	42	47	2
5 13 -1	144	145	3	8 3 0	181	182	2	10 10 0	63	59	4	4 21 0	437	449	7	10 7 1	111	114	2
6 13 -1	113	110	2	9 3 0	30	31	2	11 10 0	19	18	3	5 21 0	59	56	1	11 7 1	67	70	2
7 13 -1	40	39	2	10 3 0	120	126	1	1 11 0	170	168	4	6 21 0	192	207	3	1 8 1	136	141	2
8 13 -1	7	12	6	11 3 0	220	216	1	2 11 0	365	369	3	10 21 0	73	74	1	2 8 1	329	328	6
9 13 -1	131	126	1	12 3 0	84	84	2	3 11 0	62	62	1	12 21 0	81	83	1	3 8 1	110	206	4
1 14 -1	86	85	2	0 4 0	927	917	15	4 11 0	218	228	5	2 1 1	1399	1292	8	4 8 1	544	548	4
2 14 -1	25	31	3	1 4 0	26	31	2	5 11 0	7	3	7	3 1 1	262	260	4	5 8 1	69	69	1
3 14 -1	27	20	2	2 4 0	395	423	11	6 11 0	80	90	1	4 1 1	277	276	4	6 8 1	189	182	4
4 14 -1	39	40	2	3 4 0	203	120	3	7 11 0	50	47	1	5 1 1	132	126	2	7 8 1	130	141	3
5 14 -1	75	71	1	4 4 0	478	505	6	8 11 0	6	19	6	6 1 1	427	406	3	8 8 1	8	12	8
6 14 -1	82	77	1	5 4 0	81	82	2	9 11 0	89	88	1	7 1 1	156	159	1	9 8 1	8	13	7
7 14 -1	33	30	2	6 4 0	88	97	1	10 11 0	120	122	2	8 1 1	13	15	6	10 8 1	88	93	2
8 14 -1	40	43	2	7 4 0	101	104	4	0 12 0	123	114	1	9 1 1	138	133	2	11 8 1	14	15	5
0 15 -1	55	59	2	8 4 0	93	98	1	1 12 0	61	60	1	10 1 1	189	151	2	0 9 1	269	275	4
1 15 -1	128	125	2	9 4 0	15	20	7	2 12 0	16	20	2	11 1 1	61	67	2	1 9 1	275	275	6
2 15 -1	111	107	3	10 4 0	101	109	1	3 12 0	180	182	5	12 1 1	33	26	2	2 9 1	283	280	6
3 15 -1	181	170	3	11 4 0	19	29	3	4 12 0	4	21	4	1 2 1	1041	1037	6	3 9 1	124	136	2
4 15 -1	69	60	1	12 4 0	18	27	7	5 12 0	147	145	1	2 2 1	212	219	3	4 9 1	122	127	2
5 15 -1	112	111	2	1 5 0	828	817	17	6 12 0	32	30	2	3 2 1	929	907	6	5 9 1	42	42	1
6 15 -1	49	52	1	2 5 0	711	752	11	7 12 0	156	150	4	4 2 1	140	149	3	6 9 1	70	77	1
7 15 -1	81	81	2	3 5 0	355	380	11	8 12 0	63	62	1	5 2 1	504	500	6	7 9 1	108	113	2
8 15 -1	29	29	4	4 5 0	105	103	1	9 12 0	38	35	2	6 2 1	121	111	2	8 9 1	9	17	9
1 16 -1	59	66	2	5 5 0	225	206	3	10 12 0	36	37	1	7 2 1	153	154	3	9 9 1	70	67	1
2 16 -1	115	127	2	6 5 0	56	53	1	1 13 0	43	50	2	8 2 1	153	153	2	10 9 1	24	20	4
3 16 -1	159	166	3	7 5 0	32	20	1	2 13 0	22	17	3	9 2 1	130	123	2	11 9 1	45	45	2
4 16 -1	74	72	1	8 5 0	186	171	11	3 13 0	80	75	2	10 2 1	128	119	2	1 10 1	153	149	3
5 16 -1	111	112	2	9 5 0	162	143	2	4 13 0	7	9	6	11 2 1	64	60	2	2 10 1	341	338	5
6 16 -1	88	84	2	10 5 0	47	49	2	5 13 0	10	13	5	12 2 1	14	16	4	3 10 1	108	104	2
7 16 -1	14	14	8	11 5 0	66	67	1	6 13 0	122	121	4	0 3 1	278	290	6	4 10 1	177	173	3
8 16 -1	114	115	2	12 5 0	27	20	2	7 13 0	62	65	1	1 3 1	525	537	6	5 10 1	57	57	1
1 17 -1	49	50	2	0 6 0	507	515	6	8 13 0	83	80	5	2 3 1	1113	1104	6	6 10 1	20	21	3
2 17 -1	76	80	1	1 6 0	383	425	8	9 13 0	51	48	4	3 3 1	354	372	6	7 10 1	71	76	1
3 17 -1	87	81	1	2 6 0	84	88	1	10 13 0	17	14	4	4 3 1	126	130	2	8 10 1	93	92	1
4 17 -1	52	54	1	3 6 0	231	241	5	0 14 0	67	69	1	5 3 1	187	160	3	9 10 1	44	48	2
5 17 -1	31	33	3	4 6 0	147	154	2	1 14 0											

Table C-4

Continued.

h	k	l	10Po	10Pe	10s	h	k	l	10Po	10Pe	10s	h	k	l	10Po	10Pe	10s	h	k	l	10Po	10Pe	10s	h	k	l	10Po	10Pe	10s
2	11	1	190	191	3	11	1	2	36	39	2	2	9	2	131	121	2	4	10	2	40	40	2	2	7	3	247	239	4
3	12	1	180	193	3	12	1	2	60	62	2	3	9	2	111	112	2	5	10	2	13	12	7	3	7	3	121	130	2
4	12	1	104	106	2	0	2	2	1044	1036	6	4	9	2	173	169	3	6	10	2	39	41	2	4	7	3	149	142	2
5	12	1	76	71	1	1	2	1	420	438	6	5	9	2	152	158	2	1	19	2	49	50	2	5	7	3	201	202	4
6	12	1	90	80	2	2	2	2	340	357	6	6	9	2	147	150	2	2	19	2	0	0	1	6	7	3	93	80	2
7	12	1	184	160	2	3	2	2	464	497	7	7	9	2	48	49	1	3	19	2	63	55	3	7	7	3	138	137	2
8	12	1	86	93	1	4	2	2	411	404	6	8	9	2	167	171	2	4	19	2	31	34	2	8	7	3	105	100	1
9	12	1	30	37	3	5	2	2	222	221	4	9	9	2	26	23	2	5	19	2	17	24	4	9	7	3	73	71	1
10	12	1	40	41	3	6	2	2	80	84	2	10	9	2	44	50	2	0	20	2	67	63	2	10	7	3	24	19	3
0	13	1	174	167	2	7	2	2	114	120	2	11	9	2	36	47	2	1	20	2	52	47	2	11	7	3	23	22	3
1	13	1	146	140	2	8	2	2	59	59	3	0	10	2	200	221	4	2	20	2	93	63	2	1	0	3	320	310	6
2	13	1	126	113	2	9	2	2	174	173	3	1	10	2	176	177	3	3	20	2	16	11	5	2	0	3	230	234	4
3	13	1	47	49	2	10	2	2	42	46	2	2	10	2	191	194	3	2	0	3	230	290	4	3	0	3	177	170	3
4	13	1	31	31	3	11	2	2	58	37	2	3	10	2	65	71	1	4	0	3	604	615	6	4	0	3	242	234	5
5	13	1	149	145	3	12	2	2	53	53	2	6	10	2	64	64	1	6	0	3	212	212	3	5	0	3	116	114	2
6	13	1	109	113	2	1	3	2	499	490	6	5	10	2	27	30	2	8	0	3	125	114	2	6	0	3	143	143	2
7	13	1	27	31	2	2	3	2	663	699	6	6	10	2	107	104	2	10	0	3	110	114	2	7	0	3	53	26	9
8	13	1	7	7	6	3	3	2	127	133	2	7	10	2	194	199	3	0	1	3	199	214	3	8	0	3	119	117	2
9	13	1	120	120	1	4	3	2	510	514	6	8	10	2	124	126	2	1	1	3	511	540	4	9	0	3	11	21	10
1	14	1	85	83	1	5	3	2	135	135	2	9	10	2	0	0	1	2	1	3	70	82	1	10	0	3	37	33	2
2	14	1	26	26	3	6	3	2	369	278	5	10	10	2	52	51	2	3	1	3	95	99	2	0	9	3	66	50	1
3	14	1	24	18	3	7	3	2	184	183	3	1	11	2	131	129	3	4	1	3	44	43	1	1	9	3	122	113	2
4	14	1	39	41	2	8	3	2	192	194	4	2	11	2	71	73	1	5	1	3	175	170	3	2	9	3	217	211	3
5	14	1	69	70	1	9	3	2	163	166	3	3	11	2	130	130	2	6	1	3	64	47	1	3	9	3	119	111	2
6	14	1	81	81	1	10	3	2	73	78	1	4	11	2	71	70	1	7	2	3	106	106	4	4	9	3	34	31	2
7	14	1	37	37	2	11	3	2	40	54	3	5	11	2	150	163	3	8	1	3	91	96	2	5	9	3	47	40	2
8	14	1	39	44	2	12	3	2	87	87	1	6	11	2	97	100	2	9	1	3	136	130	2	6	9	3	245	252	3
9	14	1	8	15	7	0	4	2	710	674	7	7	11	2	84	85	1	10	1	3	23	10	2	7	9	3	44	47	2
0	15	1	52	60	2	1	6	2	701	770	7	8	11	2	85	82	1	11	1	3	46	46	2	8	9	3	159	161	2
1	15	1	136	133	2	2	6	2	300	205	4	9	11	2	0	10	1	1	2	3	296	307	6	9	9	3	16	19	6
2	15	1	110	107	2	3	6	2	266	272	6	10	11	2	23	22	3	2	2	3	465	400	6	10	9	3	25	11	4
3	15	1	191	181	3	4	6	2	179	170	3	0	12	2	171	167	3	3	2	3	210	214	3	1	10	3	71	67	1
4	15	1	69	69	1	5	6	2	249	244	5	1	12	2	125	111	2	4	2	3	439	444	4	2	10	3	200	191	3
5	15	1	110	112	2	6	6	2	126	124	2	2	12	2	43	46	2	5	2	3	44	48	2	3	10	3	81	83	1
6	15	1	48	54	1	7	6	2	230	223	4	3	12	2	65	61	1	6	2	3	40	43	2	4	10	3	107	176	4
7	15	1	89	86	2	8	6	2	102	103	2	4	12	2	127	120	2	7	2	3	70	77	1	5	10	3	56	53	2
8	15	1	25	20	3	9	6	2	153	154	3	5	12	2	96	95	1	8	2	3	73	70	2	6	10	3	173	160	3
1	16	1	59	62	2	10	6	2	42	46	2	6	12	2	59	59	1	9	2	3	131	124	2	7	10	3	70	63	1
2	16	1	120	119	2	11	6	2	50	52	2	7	12	2	39	41	2	10	2	3	56	50	1	8	10	3	102	99	2
3	16	1	160	164	2	12	6	2	81	83	1	8	12	2	71	81	2	11	2	3	47	48	2	9	10	3	25	27	4
4	16	1	71	69	1	1	5	2	313	307	7	9	12	2	50	54	2	0	3	3	310	316	4	10	10	3	9	11	9
5	16	1	100	111	2	2	5	2	101	90	2	10	12	2	35	33	2	1	3	3	312	218	4	0	11	3	149	149	3
6	16	1	63	59	2	3	5	2	85	92	2	1	13	2	126	123	2	2	3	3	114	124	2	1	11	3	134	122	2
7	16	1	9	21	9	4	5	2	123	133	2	2	13	2	141	132	2	3	3	3	319	334	6	2	11	3	119	121	2
8	16	1	23	27	2	5	5	2	100	100	2	3	13	2	100	100	2	4	3	3	243	230	4	3	11	3	86	81	1
9	17	1	123	121	2	6	5	2	175	103	3	4	13	2	82	80	1	5	3	3	144	140	3	4	11	3	48	40	2
0	17	1	69	60	2	7	6	2	129	122	2	5	13	2	159	152	2	6	3	3	240	232	5	5	11	3	197	193	3
1	17	1	75	79	1	8	6	2	166	147	3	6	13	2	180	185	2	7	3	3	122	110	2	6	11	3	115	100	2
2	17	1	84	79	1	9	6	2	40	51	2	7	13	2	80	83	1	8	3	3	37	39	2	7	11	3	111	103	2
3	17	1	80	92	1	10	6	2	106	112	2	8	13	2	54	58	2	9	3	3	59	60	1	8	11	3	16	20	6
4	17	1	35	32	3	11	6	2	41	37	2	9	13	2	43	47	2	10	3	3	82	86	2	9	11	3	32	31	3
5	17	1	16	19	4	12	6	2	32	34	2	0	14	2	215	204	4	11	3	3	47	46	2	1	12	3	146	144	3
6	17	1	0	11	1	0	6	2	78	80	1	1	14	2	47	49	2	1	4	3	93	80	1	2	12	3	146	144	3
7	17	1	32	34	2	1	6	2	503	506	7	2	14	2	157	147	3	2	4	3	61	59	1	3	12	3	263	247	3
8	18	1	27	32	2	2	6	2	100	109	2	3	14	2	19	28	4	3	4	3	493	507	6	4	12	3	195	190	3
9	18	1	43	47	3	3	6	2	104	100	2	4	14	2	70	69	1	4	4	3	250	263	4	5	12	3	85	80	1
0	18	1	29	10	3	4	6	2	56	61	1	5	14	2	48	50	2	5	4	3	103	108	3	6	12	3	52	51	2
1	18	1	26	31	3	5	6	2	148	150	2	6	14	2	159	163	3	6	4	3	140	135	2	7	12	3	20	10	3
2	18	1	20	20	3	6	6	2	95	80	2	7	14	2	47	40	2	7	4	3	39	44	2	8	12	3	45	40	2
3	18	1	139	153	1	7																							

Table C-4

Continued.

h k l 10Fo 10Fc 10a				h k l 10Fo 10Fc 10a				h k l 10Fo 10Fc 10a				h k l 10Fo 10Fc 10a				h k l 10Fo 10Fc 10a			
3 16 3	130	133	2	5 6 4	119	126	2	3 17 4	34	38	3	8 8 5	17	19	4	6 4 6	102	105	2
4 16 3	46	45	2	6 6 4	134	132	2	4 17 4	54	52	2	0 9 5	68	69	2	7 4 6	76	74	2
5 16 3	0	13	1	7 6 4	72	74	1	0 18 4	6	20	5	1 9 5	74	72	2	8 4 6	45	49	2
6 16 3	30	21	3	8 6 4	38	42	3	1 10 4	64	62	2	2 9 5	111	110	2	1 5 6	84	77	1
7 16 3	30	29	3	9 6 4	100	98	2	2 10 4	25	31	4	3 9 5	125	116	2	2 5 6	118	116	2
0 17 3	216	203	2	10 6 4	14	17	5	3 10 4	9	12	9	4 9 5	130	118	3	3 5 6	92	88	2
1 17 3	82	78	2	1 7 4	276	273	5	2 0 5	165	160	3	5 9 5	74	75	1	4 5 6	93	87	1
2 17 3	52	54	2	2 7 4	123	131	2	4 0 5	80	79	2	6 9 5	140	136	2	5 5 6	73	73	1
3 17 3	26	21	4	3 7 4	322	308	5	6 0 5	68	70	2	7 9 5	52	50	2	6 5 6	46	47	2
4 17 3	84	47	2	4 7 4	174	169	3	8 0 5	6	8	6	1 10 5	72	69	2	7 5 6	82	80	2
5 17 3	38	40	3	5 7 4	140	139	2	10 0 5	89	89	1	2 10 5	20	19	5	0 6 6	222	213	3
6 17 3	28	28	4	6 7 4	184	90	2	0 1 5	46	48	2	3 10 5	116	111	2	1 6 6	37	32	2
1 18 3	42	44	2	7 7 4	194	112	1	1 1 5	87	82	2	4 10 5	52	48	2	2 6 6	110	109	2
2 18 3	87	82	2	8 7 4	33	34	2	2 1 5	93	93	2	5 10 5	62	59	1	3 6 6	23	23	3
3 18 3	108	103	2	9 7 4	46	46	2	3 1 5	18	14	8	6 10 5	74	69	2	4 6 6	56	54	2
4 18 3	41	47	3	10 7 4	57	57	2	4 1 5	73	70	1	0 11 5	116	121	2	5 6 6	48	45	2
5 18 3	38	36	2	0 8 4	144	144	3	5 1 5	59	61	2	1 11 5	58	58	2	6 6 6	87	101	2
0 19 3	83	78	2	1 8 4	82	78	2	6 1 5	59	58	2	2 11 5	80	77	1	7 6 6	82	86	2
1 19 3	90	84	2	2 8 4	51	56	2	7 1 5	13	14	6	3 11 5	80	80	1	1 7 6	36	37	2
2 19 3	15	16	8	3 8 4	208	204	4	8 1 5	70	68	1	4 11 5	37	37	1	2 7 6	82	82	1
3 19 3	12	9	8	4 8 4	76	68	2	9 1 5	30	39	3	5 11 5	32	32	2	3 7 6	37	36	2
0 0 4	294	320	5	5 8 4	51	54	2	10 1 5	18	28	4	6 11 5	58	53	2	4 7 6	64	61	1
2 0 4	259	284	4	6 8 4	107	110	2	1 1 5	184	154	3	1 12 5	40	38	2	5 7 6	62	62	1
4 0 4	48	50	1	7 8 4	130	125	2	2 2 5	72	76	1	2 12 5	91	90	1	6 7 6	36	37	3
6 0 4	171	174	3	8 8 4	107	111	2	3 2 5	120	124	2	3 12 5	39	42	2	0 8 6	89	86	1
8 0 4	197	187	3	9 8 4	25	25	4	4 2 5	86	81	2	4 12 5	69	69	1	1 8 6	0	4	1
10 0 4	53	52	2	1 9 4	135	131	2	5 2 5	128	128	2	5 12 5	16	17	13	2 8 6	56	53	2
1 1 4	286	274	6	2 9 4	67	62	2	6 2 5	5	13	5	6 12 5	9	17	9	3 8 6	113	104	2
2 1 4	161	166	3	3 9 4	129	139	2	7 2 5	32	30	2	0 13 5	72	73	1	4 8 6	109	105	2
3 1 4	88	87	2	4 9 4	188	184	4	8 2 5	49	49	1	1 13 5	102	105	1	5 8 6	91	87	2
4 1 4	234	233	5	5 9 4	113	114	2	9 2 5	47	47	2	2 13 5	49	54	2	6 8 6	110	111	1
5 1 4	76	77	2	6 9 4	147	152	2	10 2 5	30	26	3	3 13 5	53	54	3	1 9 6	45	50	2
6 1 4	47	46	1	7 9 4	39	37	2	0 3 5	160	157	3	4 13 5	57	55	2	2 9 6	54	58	2
7 1 4	41	37	2	8 9 4	23	26	3	1 3 5	193	187	4	5 13 5	49	48	2	3 9 6	92	84	1
8 1 4	133	132	3	9 9 4	57	59	2	2 3 5	153	188	3	1 14 5	42	39	3	4 9 6	23	24	2
9 1 4	51	49	1	0 10 4	145	144	2	3 3 5	31	35	1	2 14 5	44	43	3	5 9 6	7	3	6
10 1 4	48	51	3	1 10 4	132	108	2	4 3 5	106	104	2	3 14 5	52	48	2	0 10 6	186	177	2
11 1 4	33	35	3	2 10 4	46	44	2	5 3 5	26	18	2	4 14 5	85	77	2	1 10 6	64	64	1
0 2 4	318	321	5	3 10 4	74	80	1	6 3 5	164	168	3	0 15 5	11	12	11	2 10 6	32	30	2
1 2 4	211	211	3	4 10 4	134	132	2	7 3 5	91	87	1	1 15 5	62	58	2	3 10 6	12	10	2
2 2 4	235	230	5	5 10 4	89	81	1	8 3 5	41	47	2	2 15 5	43	39	3	4 10 6	82	71	2
3 2 4	279	287	5	6 10 4	172	171	2	9 3 5	32	39	3	3 15 5	16	18	7	5 10 6	36	35	3
4 2 4	171	145	3	7 10 4	82	81	1	10 3 5	24	26	2	4 15 5	8	17	8	1 11 6	48	47	2
5 2 4	50	56	1	8 10 4	75	72	2	1 14 5	140	133	2	1 16 5	31	26	3	2 11 6	74	72	2
6 2 4	48	43	2	1 11 4	191	199	4	2 14 5	112	108	2	2 16 5	50	50	2	3 11 6	100	101	2
7 2 4	128	122	2	2 11 4	165	159	4	3 14 5	233	228	4	3 16 5	20	33	3	4 11 6	51	52	2
8 2 4	44	46	2	3 11 4	204	205	3	4 14 5	140	135	2	4 16 5	71	66	2	0 12 6	64	68	2
9 2 4	107	103	2	4 11 4	38	32	2	5 14 5	38	39	2	0 17 5	32	27	3	1 12 6	35	36	3
10 2 4	0	11	1	5 11 4	47	40	2	6 14 5	42	41	2	1 17 5	38	42	3	2 12 6	40	39	2
11 2 4	44	44	1	6 11 4	21	17	3	7 14 5	22	22	3	2 17 5	4	12	4	3 12 6	49	51	2
1 3 4	218	220	3	7 11 4	6	13	6	8 14 5	34	28	3	0 0 6	89	84	2	4 12 6	6	10	6
2 3 4	231	239	5	8 11 4	84	82	2	9 14 5	35	42	3	2 0 6	88	84	2	2 13 6	54	54	2
3 3 4	262	249	5	0 12 4	110	108	2	10 14 5	9	6	8	4 0 6	87	88	1	3 13 6	58	59	2
4 3 4	138	134	2	1 12 4	161	161	3	0 5 5	190	191	3	6 0 6	80	84	1	4 13 6	59	58	2
5 3 4	108	104	2	2 12 4	46	42	2	1 5 5	199	198	4	8 0 6	24	27	3	0 14 6	44	51	2
6 3 4	121	121	2	3 12 4	37	36	1	2 5 5	149	149	2	1 1 6	127	129	2	1 14 6	24	27	5
7 3 4	92	93	2	4 12 4	79	71	1	3 5 5	40	36	2	2 1 6	128	133	2	2 14 6	21	23	5
8 3 4	26	28	1	5 12 4	48	38	2	4 5 5	162	154	3	3 1 6	117	119	2	3 14 6	34	41	3
9 3 4	70	75	1	6 12 4	86	87	1	5 5 5	188	187	2	4 1 6	91	86	2	1 15 6	16	16	6
10 3 4	65	67	3	7 12 4	19	28	5	6 5 5	168	175	3	5 1 6	88	68	1	2 15 6	43	41	2
11 3 4	27	27	3	1 13 4	43	44	2	7 5 5	14	12	5	6 1 6	85	56	2	2 0 7	211	203	2
0 4 4	207	204	4	2 13 4	74	78	2	8 5 5	126	128	2	7 1 6	85	80	2	4 0 7	76	74	1
1 4 4	168	144	2	3 13 4	107	103	2	9 5 5	74	69	2	8 1 6	14	23	8	6 0 7	39	41	2
2 4 4	120	123	2	4 13 4	0	13	1	1 6 5	109	106	2	9 1 6	7	15	6	0 1 7	167	163	2
3 4 4	178	187	3	5 13 4	113	118	2	2 6 5	217	199	4	0 2 6	177	168	3	1 1 7	151	144	2
4 4 4	210	222	5	6 13 4	40	43	2	3 6 5	187	188	3	1 2 6	143	141	2	2 1 7	16	19	5
5 4 4	177	184	3	7 13 4	0	15	1	4 6 5	83	79	1	2 2 6	73	73	1	3 1 7	36	34	2
6 4 4	124	139	2	0 14 4	98	94	2	5 6 5	272	270	3	3 2 6	96	94	1	4 1 7	114	107	2
7 4 4	370	163	3	1 14 4	135	107	2	6 6 5	106	103	2	4 2 6	44	41	2	5 1 7	71	70	2
8 4 4	143	134	2	2 14 4	81	79	1	7 6 5	46	51	2	5 2 6	124	123	3	6 1 7	18	22	5
9 4 4	58	59	1	3 14 4	87	71	1	8 6 5	32	29	3	6 2 6	67	68	1	7 1 7	28	32	3
10 4 4	44	48	2	4 14 4	120	111	2	9 6 5	28	37	3	7 2 6	49	49	2	1 2 7	102	94	1
11 4 4	8	8	8	5 14 4	33	39	3	0 7 5	144	140	2	8 2 6	31	34	3	2 2 7	67	62	1
1 5 4	203	202	3	6 14 4	101	99	2	1 7 5	32	25	2	9 2 6	59	58	2	3 2 7	88	83	1
2 5 4	159	158	2	1 15 4	81	78	1	2 7 5	128	127	2	1 3 6	60	61	2	4 2 7	74	70	2
3 5 4	20	14	2	2 15 4	69	69	1	3 7 5	95	83	1								

Table C-4

Continued.

h	k	l	10Fo	10Fc	10s	h	k	l	10Fo	10Fc	10s	h	k	l	10Fo	10Fc	10s	h	k	l	10Fo	10Fc	10s						
4	4	7	55	51	2	0	7	7	131	125	2	2	10	7	88	79	2	0	2	8	29	28	3	1	5	8	0	7	1
5	4	7	34	36	3	1	7	7	41	37	2	2	10	7	82	82	2	1	2	8	104	104	2	2	5	8	37	31	2
4	4	7	52	51	2	2	7	7	31	32	4	0	11	7	84	84	2	2	2	8	71	67	2	3	5	8	0	10	1
0	5	7	89	86	1	3	7	7	63	59	2	1	11	7	52	56	2	3	2	8	51	43	2	0	6	8	67	57	2
1	5	7	143	135	2	4	7	7	53	54	2	2	11	7	10	8	10	4	2	8	14	16	7	1	6	8	8	14	7
2	5	7	46	50	2	1	8	7	83	52	2	1	12	7	0	5	1	1	3	8	0	2	1	2	6	8	45	44	2
3	5	7	24	19	4	2	8	7	29	31	3	2	12	7	0	4	1	2	3	8	47	46	2	3	6	8	9	14	9
4	5	7	37	37	3	3	8	7	46	40	2	0	0	8	143	133	1	3	3	8	23	28	3	1	7	8	36	30	2
5	5	7	23	24	3	4	8	7	23	33	4	2	0	8	93	87	2	4	3	8	69	68	2	2	7	8	12	1	6
1	6	7	166	103	2	0	3	7	63	71	2	4	0	8	42	43	2	0	4	8	43	48	2	0	8	8	51	53	2
2	6	7	32	32	2	1	3	7	74	78	2	1	1	8	19	22	6	1	4	8	38	35	3	1	8	8	48	48	2
3	6	7	90	89	2	2	9	7	84	82	2	2	1	8	44	42	2	2	4	8	23	28	4	0	8	8	51	53	2
4	6	7	47	44	2	3	9	7	85	79	2	3	1	8	13	9	7	3	4	8	34	32	2	1	8	8	48	48	2
5	6	7	87	91	2	1	10	7	33	38	3	4	1	8	60	60	2	4	4	8	64	57	2						

APPENDIX D**CRYSTALLOGRAPHY DATA FOR 3**

Table D-1**Bond lengths [Å] and angles [°] for 3.**

C1-C(14)	1.740(6)	N-C(21)	1.403(7)
N-C(3)	1.440(7)	N-H(1N)	0.85(5)
O(1)-C(1)	1.334(7)	O(1)-C(4)	1.453(8)
C(1)-O(2)	1.201(6)	C(1)-C(2)	1.516(8)
C(2)-O(3)	1.405(6)	C(2)-C(3)	1.543(7)
C(2)-H(2)	1.01(5)	O(3)-C(5)	1.420(7)
C(3)-C(11)	1.515(8)	C(3)-H(3)	1.00(5)
O(4)-C(22)	1.358(7)	O(4)-C(6)	1.424(8)
C(4)-H(4A)	0.9600	C(4)-H(4B)	0.9600
C(4)-H(4C)	0.9600	C(5)-H(5A)	0.9600
C(5)-H(5B)	0.9600	C(5)-H(5C)	0.9600
C(6)-H(6C)	0.94(6)	C(6)-H(6B)	0.97(6)
C(6)-H(6A)	1.35(11)	C(11)-C(12)	1.372(7)
C(11)-C(16)	1.379(8)	C(12)-C(13)	1.384(9)
C(12)-H(12)	1.02(5)	C(13)-C(14)	1.356(9)
C(13)-H(13)	1.02(7)	C(14)-C(15)	1.362(10)
C(15)-C(16)	1.384(9)	C(15)-H(15)	1.27(9)
C(16)-H(16)	1.00(6)	C(21)-C(22)	1.391(8)
C(21)-C(26)	1.392(8)	C(22)-C(23)	1.373(9)
C(23)-C(24)	1.376(12)	C(23)-H(23A)	0.9300
C(24)-C(25)	1.338(12)	C(24)-H(24)	0.98(8)
C(25)-C(26)	1.390(10)	C(25)-H(25)	0.85(6)
C(26)-H(26)	1.04(4)		
C(21)-N-C(3)	121.2(5)	C(21)-N-H(1N)	106(4)
C(3)-N-H(1N)	120(3)	C(1)-O(1)-C(4)	117.6(5)
O(2)-C(1)-O(1)	122.9(6)	O(2)-C(1)-C(2)	125.8(6)
O(1)-C(1)-C(2)	111.3(5)	O(3)-C(2)-C(1)	111.1(5)
O(3)-C(2)-C(3)	105.9(4)	C(1)-C(2)-C(3)	110.2(5)
O(3)-C(2)-H(2)	111(3)	C(1)-C(2)-H(2)	110(3)
C(3)-C(2)-H(2)	108(2)	C(2)-O(3)-C(5)	112.8(5)
N-C(3)-C(11)	112.8(5)	N-C(3)-C(2)	109.5(5)
C(11)-C(3)-C(2)	111.8(5)	N-C(3)-H(3)	111(3)
C(11)-C(3)-H(3)	108(3)	C(2)-C(3)-H(3)	103(3)
C(22)-O(4)-C(6)	118.3(7)	O(1)-C(4)-H(4A)	109.5
O(1)-C(4)-H(4B)	109.5	H(4A)-C(4)-H(4B)	109.5
O(1)-C(4)-H(4C)	109.5	H(4A)-C(4)-H(4C)	109.5
H(4B)-C(4)-H(4C)	109.5	O(3)-C(5)-H(5A)	109.5
O(3)-C(5)-H(5B)	109.5	H(5A)-C(5)-H(5B)	109.5
O(3)-C(5)-H(5C)	109.5	H(5A)-C(5)-H(5C)	109.5
H(5B)-C(5)-H(5C)	109.5	O(4)-C(6)-H(6C)	108(4)
O(4)-C(6)-H(6B)	108(4)	H(6C)-C(6)-H(6B)	117(6)
O(4)-C(6)-H(6A)	101(4)	H(6C)-C(6)-H(6A)	105(6)
H(6B)-C(6)-H(6A)	116(6)	C(12)-C(11)-C(16)	118.3(6)
C(12)-C(11)-C(3)	123.2(5)	C(16)-C(11)-C(3)	118.5(5)
C(11)-C(12)-C(13)	119.8(6)	C(11)-C(12)-H(12)	126(3)
C(13)-C(12)-H(12)	114(3)	C(14)-C(13)-C(12)	120.7(6)
C(14)-C(13)-H(13)	120(3)	C(12)-C(13)-H(13)	119(3)
C(15)-C(14)-C(13)	120.9(6)	C(15)-C(14)-C1	119.4(7)
C(13)-C(14)-C1	119.7(6)	C(14)-C(15)-C(16)	118.3(7)
C(14)-C(15)-H(15)	129(4)	C(16)-C(15)-H(15)	113(4)
C(15)-C(16)-C(11)	121.9(7)	C(15)-C(16)-H(16)	121(3)
C(11)-C(16)-H(16)	117(3)	C(22)-C(21)-C(26)	119.1(6)
C(22)-C(21)-N	119.2(6)	C(26)-C(21)-N	121.7(6)
O(4)-C(22)-C(23)	124.8(7)	O(4)-C(22)-C(21)	114.4(5)

Table D-2

Anisotropic displacement parameters [$\text{\AA} \times 10^3$] for 3. The anisotropic displacement factor exponent takes the form: $-2\pi^2 \{ (ha^*)^2 U_{11} + \dots + 2hka^*b^*U_{12} \}$

	U11	U22	U33	U23	U13	U12
C1	143 (2)	137 (2)	127 (2)	-63 (2)	39 (2)	-65 (1)
N	51 (3)	67 (3)	72 (4)	2 (3)	9 (3)	9 (3)
O (1)	75 (3)	84 (3)	61 (3)	-16 (2)	4 (2)	10 (2)
C (1)	50 (3)	69 (4)	65 (4)	-4 (4)	9 (3)	-2 (3)
C (2)	49 (3)	64 (4)	61 (4)	-18 (3)	-4 (3)	-3 (3)
O (2)	102 (3)	70 (3)	81 (3)	3 (3)	12 (3)	17 (2)
O (3)	59 (2)	85 (3)	79 (3)	-20 (3)	-3 (2)	-11 (2)
C (3)	46 (3)	69 (4)	62 (4)	0 (3)	0 (3)	3 (3)
O (4)	72 (3)	87 (3)	105 (4)	-16 (3)	20 (3)	19 (2)
C (4)	112 (6)	114 (6)	64 (4)	-8 (4)	-8 (4)	24 (5)
C (5)	65 (4)	112 (5)	122 (7)	-30 (5)	-4 (5)	-23 (4)
C (6)	92 (6)	116 (7)	125 (9)	-11 (7)	11 (6)	28 (6)
C (11)	45 (3)	59 (3)	59 (3)	4 (3)	-3 (3)	-4 (3)
C (12)	56 (3)	76 (4)	59 (3)	6 (4)	-5 (4)	-7 (3)
C (13)	67 (4)	112 (6)	61 (4)	-8 (4)	-5 (4)	-32 (5)
C (14)	96 (5)	75 (5)	72 (5)	-24 (4)	26 (4)	-35 (4)
C (15)	84 (5)	76 (5)	88 (5)	-5 (4)	13 (5)	-7 (4)
C (16)	67 (4)	71 (4)	72 (4)	-13 (4)	-9 (4)	-3 (4)
C (21)	50 (3)	88 (4)	49 (3)	-5 (3)	2 (3)	-6 (3)
C (22)	49 (3)	100 (5)	69 (4)	-21 (4)	9 (3)	-7 (4)
C (23)	79 (5)	122 (7)	90 (5)	-33 (6)	24 (5)	-10 (4)
C (24)	87 (6)	164 (10)	63 (5)	-17 (6)	17 (4)	-27 (7)
C (25)	91 (6)	128 (9)	64 (5)	10 (6)	-7 (5)	-30 (6)
C (26)	58 (4)	97 (5)	62 (4)	5 (4)	-2 (3)	-3 (4)

Table D-3

Hydrogen coordinates ($\times 10^4$) and isotropic displacement parameters ($\text{\AA}^2 \times 10^3$) for 3.

	x	y	z	U(eq)
H(1N)	-1953 (42)	-9033 (25)	-8172 (73)	60 (18)
H(2)	-4476 (38)	-8262 (23)	-6772 (57)	46 (14)
H(3)	-3125 (39)	-7980 (23)	-8852 (72)	58 (15)
H(4A)	-3214 (6)	-8569 (4)	-1683 (9)	145
H(4B)	-2287 (6)	-8973 (4)	-2712 (9)	145
H(4C)	-3481 (6)	-9308 (4)	-2331 (9)	145
H(5A)	-5463 (5)	-9598 (4)	-9075 (10)	150
H(5B)	-5826 (5)	-8933 (4)	-8115 (10)	150
H(5C)	-5311 (5)	-9551 (4)	-7118 (10)	150
H(6C)	1167 (57)	-9910 (29)	-8982 (91)	89 (23)
H(6B)	165 (53)	-10488 (31)	-8844 (91)	86 (23)
H(6A)	481 (66)	-10048 (44)	-11041 (146)	166 (34)
H(12)	-1084 (40)	-7954 (23)	-5331 (61)	50 (14)
H(13)	-701 (54)	-6968 (26)	-3838 (85)	95 (20)
H(15)	-3713 (70)	-5934 (44)	-6072 (112)	159 (32)
H(16)	-3917 (50)	-7015 (27)	-7481 (77)	74 (18)
H(23A)	1236 (6)	-9082 (5)	-11041 (11)	116
H(24)	1480 (64)	-8078 (38)	-12047 (106)	115 (27)
H(25)	9 (55)	-7198 (35)	-11138 (89)	86 (29)
H(26)	-1450 (36)	-7379 (21)	-9496 (51)	33 (11)

Table D-4

Observed and calculated structure factors for 3.

h	k	l	10Fo	10Fc	10a	h	k	l	10Fo	10Fc	10a	h	k	l	10Fo	10Fc	10a	h	k	l	10Fo	10Fc	10a	h	k	l	10Fo	10Fc	10a
0	0	-8	122	117	7	4	3	-6	32	28	31	8	3	-5	84	44	10	8	0	-4	187	188	6	5	3	-4	106	102	7
2	0	-8	82	74	8	7	3	-6	44	51	13	9	3	-5	7	25	6	10	0	-4	56	49	11	6	3	-4	139	141	7
1	1	-8	19	23	19	0	3	-6	73	76	8	1	4	-5	136	120	5	1	1	-4	296	275	6	7	9	-4	28	30	28
3	1	-8	26	38	26	0	4	-6	39	51	16	2	4	-5	164	164	5	2	1	-4	164	164	3	8	3	-4	0	24	1
2	1	-8	37	13	12	1	4	-6	0	17	1	3	4	-5	223	221	4	3	1	-4	111	95	4	9	3	-4	42	52	15
0	2	-8	37	31	15	2	4	-6	110	106	5	4	4	-5	143	138	4	4	1	-4	239	231	4	0	10	-4	132	133	5
1	2	-8	82	97	9	3	4	-6	49	48	9	5	4	-5	21	37	21	5	1	-4	76	73	7	1	10	-4	97	103	7
2	2	-8	45	62	15	4	4	-6	98	103	8	6	4	-5	43	35	20	6	1	-4	68	68	6	2	10	-4	39	34	9
1	3	-8	17	5	16	5	4	-6	20	28	20	7	4	-5	24	17	24	7	1	-4	35	33	14	3	10	-4	79	74	6
2	3	-8	39	48	19	6	4	-6	112	97	6	8	4	-5	25	37	25	8	1	-4	125	123	7	4	10	-4	134	120	5
0	4	-8	39	38	28	7	4	-6	57	68	12	9	4	-5	37	40	14	9	1	-4	32	46	26	5	10	-4	59	73	17
1	4	-8	0	30	1	1	5	-6	67	69	7	0	5	-5	180	177	4	10	1	-4	89	45	9	6	10	-4	151	159	7
2	0	-7	200	196	5	2	5	-6	104	115	7	1	5	-5	186	184	4	0	2	-4	314	304	6	7	10	-4	73	74	11
4	0	-7	63	64	13	3	5	-6	93	90	7	2	5	-5	127	126	4	1	2	-4	217	207	4	8	10	-4	65	65	10
6	0	-7	32	32	26	4	5	-6	80	98	8	3	5	-5	45	38	12	2	2	-4	236	233	4	1	11	-4	176	183	4
0	1	-7	162	182	7	5	5	-6	74	67	11	4	5	-5	181	148	4	3	2	-4	388	288	6	2	11	-4	150	151	4
1	1	-7	137	131	8	6	5	-6	27	44	27	5	5	-5	105	107	8	4	2	-4	175	169	3	3	11	-4	195	185	4
2	1	-7	0	18	1	7	5	-6	55	84	14	6	5	-5	194	148	6	5	2	-4	39	42	6	4	11	-4	37	25	19
3	1	-7	0	29	1	8	5	-6	208	198	4	7	5	-5	6	7	1	6	2	-4	43	46	11	5	11	-4	58	39	13
4	1	-7	186	89	7	3	6	-6	6	18	1	8	5	-5	132	127	7	7	2	-4	116	117	5	6	11	-4	31	14	31
5	1	-7	73	69	9	2	6	-6	188	186	5	9	5	-5	62	67	10	8	2	-4	31	38	31	7	11	-4	35	22	14
6	1	-7	38	23	21	3	6	-6	71	22	29	1	6	-5	89	101	5	9	2	-4	82	93	5	8	11	-4	80	76	7
1	2	-7	86	83	14	4	6	-6	38	47	28	2	6	-5	212	196	4	10	2	-4	38	37	12	9	12	-4	94	84	6
2	2	-7	43	55	20	5	6	-6	55	42	19	3	6	-5	97	97	8	1	3	-4	222	229	4	1	12	-4	130	142	5
3	2	-7	18	42	18	6	6	-6	91	97	19	4	6	-5	82	82	6	2	3	-4	242	236	4	2	12	-4	33	43	23
4	2	-7	58	68	13	7	6	-6	73	83	8	5	6	-5	941	954	4	3	3	-4	282	288	6	3	12	-4	75	84	8
5	2	-7	82	90	9	1	7	-6	6	33	8	6	6	-5	98	92	7	4	3	-4	148	133	4	4	12	-4	62	70	13
6	2	-7	26	29	25	2	7	-6	64	71	12	7	6	-5	58	57	15	5	3	-4	185	184	5	5	12	-4	37	23	18
0	3	-7	19	28	19	3	7	-6	9	30	1	8	6	-5	36	23	26	6	3	-4	123	125	4	6	12	-4	66	79	11
1	3	-7	9	69	9	4	7	-6	44	58	25	0	7	-5	115	122	5	7	3	-4	80	84	7	7	12	-4	44	30	12
2	3	-7	0	3	1	5	7	-6	63	57	9	1	7	-5	17	30	16	8	3	-4	25	26	25	1	13	-4	24	40	24
3	3	-7	40	42	13	6	7	-6	34	33	22	2	7	-5	119	121	5	9	3	-4	73	67	10	2	13	-4	43	61	42
4	3	-7	33	28	21	0	8	-6	84	82	14	3	7	-5	92	80	5	18	3	-4	51	57	14	3	13	-4	71	93	14
5	3	-7	23	33	22	1	8	-6	8	7	1	4	7	-5	112	117	5	0	4	-4	214	205	4	4	13	-4	6	14	6
6	3	-7	37	31	27	2	8	-6	8	43	1	5	7	-5	16	17	18	1	4	-4	132	135	4	5	13	-4	183	183	8
1	4	-7	85	87	8	2	8	-6	87	94	11	6	7	-5	163	171	6	2	4	-4	126	122	4	6	13	-4	28	34	27
2	4	-7	167	164	6	4	8	-6	105	108	7	7	7	-5	77	95	11	3	4	-4	175	185	3	0	14	-4	76	84	9
3	4	-7	37	69	12	5	8	-6	79	79	9	0	7	-5	38	39	15	4	4	-4	222	223	4	1	14	-4	97	88	8
4	4	-7	46	53	15	6	8	-6	79	101	9	1	8	-5	74	76	8	5	4	-4	174	179	4	2	14	-4	65	62	10
5	4	-7	33	32	33	1	9	-6	0	46	1	2	8	-5	48	46	10	6	4	-4	118	131	5	3	14	-4	41	64	32
0	5	-7	52	76	17	2	9	-6	25	49	25	3	8	-5	82	86	6	7	4	-4	172	161	4	4	14	-4	104	99	9
1	5	-7	132	121	8	3	9	-6	84	78	8	4	8	-5	75	73	6	0	4	-4	136	127	7	5	14	-4	32	29	32
2	5	-7	51	50	12	4	9	-6	0	28	1	5	8	-5	44	45	20	9	4	-4	53	57	11	6	14	-4	87	89	9
3	5	-7	29	17	29	5	9	-6	16	4	18	6	8	-5	62	24	14	10	4	-4	29	45	29	1	15	-4	47	67	18
4	5	-7	26	33	26	0	10	-6	166	168	6	7	8	-5	34	33	26	1	5	-4	199	198	4	2	15	-4	45	55	26
1	6	-7	97	99	9	1	10	-6	31	87	30	8	9	-5	61	68	11	2	5	-4	0	22	1	3	15	-4	72	61	12
2	6	-7	32	93	32	2	10	-6	28	25	27	1	9	-5	59	72	8	4	5	-4	134	135	4	5	15	-4	73	65	8
3	6	-7	86	82	11	4	10	-6	72	72	9	2	9	-5	89	96	6	5	5	-4	0	8	1	6	16	-4	0	31	1
4	6	-7	20	35	19	1	11	-6	0	38	1	3	9	-5	119	106	5	6	5	-4	124	133	5	1	16	-4	51	54	12
5	6	-7	111	113	8	2	11	-6	62	63	12	4	9	-5	120	111	7	7	5	-4	131	139	4	2	16	-4	31	26	36
1	7	-7	52	39	11	3	11	-6	93	88	8	5	9	-5	63	71	11	8	5	-4	79	86	10	3	16	-4	48	38	15
2	7	-7	10	25	10	0	12	-6	0	52	1	6	9	-5	122	128	6	9	5	-4	25	19	23	1	17	-4	45	19	12
3	7	-7	35	51	24	1	12	-6	0	52	1	7	9	-5	88	44	13	10	5	-4	459	460	6	2	17	-4	122	115	7
4	7	-7	60	50	17	2	12	-6	15	32	14	1	10	-5	19	57	11	0	6	-4	489	489	6	2	17	-4	281	242	4
1	8	-7	0	51	1	1	13	-6	25	49	28	2	10	-5	42	21	20	1	6	-4	273	282	6	4	17	-4	421	591	5
2	8	-7	0	29	1	2	13	-6	160	164	4	3	10	-5	111	104	8	2	6	-4	157	148	6	5	17	-4	199	198	4
3	8	-7	0	46	1	4	13	-6	70	68	7	4	10	-5	38	43	19	3	6	-4	49	48	8	8	17	-4	104	103	5
0	9	-7	50	63	13	6	13	-6	60	73	7	5	10	-5	54	55	12	4	6	-4	239	245	4	10	17	-4	108	101	7
1	9	-7	39	67	23	8	13	-6	14	6	13	6	10	-5	70	64	8	5	6	-4	122	127	5	0	1	-3	212	222	3
2	9	-7	84	70	13	10	13	-6	82	82	7	7	10	-5	34	34	34	6	6										

Table D-4

Continued.

k	k	l	10Po	10Po	10e	h	k	l	10Po	10Po	10e	h	k	l	10Po	10Po	10e	h	k	l	10Po	10Po	10e	h	k	l	10Po	10Po	10e
6	3	-3	225	225	4	8	11	-3	0	19	1	10	3	-2	68	78	12	7	11	-2	64	83	12	9	2	-1	115	122	4
7	3	-3	102	104	5	9	11	-3	0	27	1	11	3	-2	20	84	20	8	11	-3	66	72	13	10	2	-1	107	111	8
8	3	-3	42	38	12	1	12	-9	106	185	4	12	3	-2	41	54	19	9	11	-2	0	14	1	11	2	-1	38	46	38
9	3	-3	86	53	14	2	12	-3	128	129	8	0	4	-2	677	667	5	18	11	-2	34	23	23	12	2	-1	35	17	14
10	3	-3	26	26	26	3	12	-3	223	222	4	1	4	-2	784	788	8	0	12	-2	147	183	4	0	3	-1	261	272	5
11	3	-3	35	45	14	4	12	-3	181	171	4	2	4	-2	201	210	3	1	12	-2	110	141	5	1	3	-1	501	524	4
1	4	-3	79	75	4	5	12	-3	89	85	7	3	4	-2	269	273	6	2	12	-2	80	38	9	2	3	-1	1114	1094	5
2	4	-3	72	61	4	6	12	-3	38	44	10	4	4	-2	189	178	4	3	12	-2	62	58	8	3	3	-1	148	147	5
3	4	-3	495	496	5	7	12	-3	0	19	1	5	4	-2	239	243	4	4	12	-2	111	120	6	4	1	-1	328	131	3
4	4	-3	260	263	4	8	12	-3	26	42	24	6	4	-2	128	126	4	5	12	-2	71	89	8	5	3	-1	186	163	3
5	4	-3	177	184	3	9	12	-3	168	163	4	7	4	-2	214	227	4	6	12	-2	84	85	11	6	3	-1	209	216	4
6	4	-3	130	127	4	1	13	-3	97	104	5	8	4	-2	104	180	5	7	12	-2	0	33	1	7	3	-1	147	149	4
7	4	-3	24	42	23	2	13	-3	51	61	9	9	4	-2	184	147	6	8	12	-2	56	73	15	8	3	-1	63	63	8
8	4	-3	146	107	8	3	13	-3	0	38	1	10	4	-2	35	40	21	9	12	-2	89	47	9	9	3	-1	103	105	6
9	4	-3	87	51	13	4	13	-3	145	171	7	11	4	-2	34	46	34	1	13	-2	102	102	6	10	3	-1	73	89	12
10	4	-3	42	64	19	5	13	-3	85	84	8	1	5	-2	296	301	6	2	13	-2	134	124	5	11	3	-1	65	65	11
11	4	-3	0	18	1	6	13	-3	46	58	15	2	5	-2	84	97	4	3	13	-2	88	92	6	12	3	-1	13	38	12
0	5	-3	406	423	5	7	13	-3	81	64	17	3	5	-2	85	85	4	4	13	-2	70	71	6	1	6	-1	116	114	3
1	5	-3	329	220	4	8	13	-3	30	44	30	4	6	-2	122	123	3	5	13	-2	121	148	7	2	4	-1	331	334	5
2	5	-3	401	398	6	1	14	-3	37	26	11	5	6	-2	115	118	4	6	13	-2	149	143	7	3	4	-1	290	300	6
3	5	-3	247	248	4	2	14	-3	81	41	8	6	6	-2	272	178	4	7	13	-2	81	73	9	4	4	-1	292	302	6
4	5	-3	139	134	3	3	14	-3	13	47	13	7	6	-2	121	129	4	8	13	-2	42	51	20	5	4	-1	822	830	5
5	5	-3	139	134	4	4	14	-3	30	33	29	8	6	-2	147	180	4	9	13	-2	31	40	18	6	4	-1	169	165	4
6	5	-3	71	67	6	5	14	-3	86	81	9	9	6	-2	25	48	34	0	14	-2	190	179	4	7	4	-1	82	53	11
7	5	-3	108	103	8	6	14	-3	87	97	19	10	6	-2	189	184	7	1	14	-2	49	47	9	8	4	-1	212	204	4
8	5	-3	82	80	8	7	14	-3	27	65	27	11	6	-2	40	31	18	2	14	-2	141	133	5	9	4	-1	78	81	6
9	5	-3	77	81	10	8	14	-3	33	60	32	12	6	-2	79	82	4	3	14	-2	0	21	1	10	4	-1	66	70	12
10	5	-3	87	84	8	1	15	-3	96	79	11	1	6	-2	563	582	5	4	14	-2	10	64	10	11	4	-1	30	48	30
11	5	-3	94	78	7	2	15	-3	0	39	7	2	6	-2	164	167	3	5	14	-2	28	45	23	12	4	-1	14	26	14
1	6	-3	75	68	9	3	15	-3	107	81	7	3	6	-2	102	103	4	6	14	-2	154	144	6	0	5	-1	108	112	3
2	6	-3	274	282	8	4	15	-3	64	67	9	4	6	-2	80	64	7	7	14	-2	49	49	15	1	5	-1	66	69	4
3	6	-3	231	221	4	5	15	-3	31	33	31	5	6	-2	145	151	4	8	14	-2	41	11	17	2	5	-1	437	464	5
4	6	-3	167	112	4	6	15	-3	60	67	10	6	6	-2	95	87	5	1	15	-2	89	87	6	3	5	-1	181	192	3
5	6	-3	20	24	21	1	16	-3	28	48	28	7	6	-2	88	91	5	2	15	-2	0	34	1	4	5	-1	171	174	3
6	6	-3	67	77	6	2	16	-3	48	50	14	8	6	-2	186	183	5	3	15	-2	116	110	8	5	5	-1	268	249	4
7	6	-3	65	73	7	3	16	-3	109	111	7	9	6	-2	181	183	6	4	15	-2	94	93	8	6	5	-1	104	100	5
8	6	-3	85	90	9	4	16	-3	18	42	17	10	6	-2	69	68	13	5	15	-2	88	77	9	7	5	-1	99	96	6
9	6	-3	81	81	31	5	16	-3	22	18	22	11	6	-2	0	24	1	6	15	-2	47	52	8	8	5	-1	124	123	5
10	6	-3	86	68	10	6	17	-3	178	145	6	1	7	-2	292	299	6	7	15	-2	0	13	1	9	5	-1	64	62	8
0	7	-3	249	248	4	1	17	-3	47	58	14	2	7	-2	383	382	6	8	16	-2	38	53	25	10	5	-1	119	125	7
1	7	-3	441	457	6	2	17	-3	38	39	21	3	7	-2	262	284	4	1	16	-2	101	88	9	11	5	-1	78	57	11
2	7	-3	239	232	4	3	17	-3	32	10	22	4	7	-2	79	82	5	2	16	-2	47	65	19	12	5	-1	55	55	9
3	7	-3	123	126	4	4	17	-3	37	36	20	5	7	-2	188	182	4	3	16	-2	88	80	8	1	4	-1	58	58	5
4	7	-3	133	127	4	1	18	-3	24	30	23	6	7	-2	187	99	9	4	16	-2	20	38	28	2	6	-1	228	259	4
5	7	-3	184	180	4	2	18	-3	44	49	24	7	7	-2	36	31	13	5	16	-2	35	42	29	3	6	-1	121	110	3
6	7	-3	81	80	6	3	18	-3	104	88	9	8	7	-2	23	10	23	6	16	-2	54	72	13	4	6	-1	226	229	4
7	7	-3	136	133	5	0	18	-3	88	64	10	9	7	-2	38	40	27	1	17	-2	47	43	15	5	6	-1	235	234	4
8	7	-3	95	84	9	0	18	-3	874	849	4	10	7	-2	59	51	23	2	17	-2	51	20	13	6	6	-1	139	149	4
9	7	-3	70	64	9	2	18	-3	476	470	5	11	7	-2	88	43	13	3	17	-2	0	17	1	7	6	-1	159	162	4
10	7	-3	42	22	13	4	18	-3	389	184	3	0	8	-2	438	428	6	4	17	-2	46	87	18	8	6	-1	24	41	23
1	8	-3	294	291	6	6	18	-3	129	132	4	1	8	-2	203	185	4	5	17	-2	58	85	11	9	6	-1	35	26	15
2	8	-3	216	220	4	8	18	-3	94	95	5	2	8	-2	124	134	4	6	17	-2	25	20	25	10	6	-1	129	134	7
3	8	-3	186	162	4	10	18	-3	38	84	27	3	8	-2	43	35	10	0	18	-2	88	78	8	11	6	-1	23	20	23
4	8	-3	229	224	4	12	18	-3	81	83	13	4	8	-2	188	186	4	1	18	-2	65	59	9	12	6	-1	15	13	14
5	8	-3	189	188	9	1	1	-2	681	880	5	5	8	-2	110	116	8	2	18	-2	33	15	19	0	7	-1	228	237	4
6	8	-3	131	141	5	3	1	-2	893	844	5	6	8	-2	84	95	5	3	18	-2	0	30	1	1	7	-1	244	253	4
7	8	-3	10	31	15	3	1	-2	894	682	5	7	8	-2	76	90	7	4	18	-2	33	38	20	2	7	-1	148	145	3
8	8	-3	109	114	7	4	1	-2	81	77	4	8	8	-2	39	41	32	5	19	-2	80	81	14	3	7	-1	346	359	6
9	8	-3	15	24	14	5	1	-2	135	128	4	9	8	-2	114	93	8	6	19	-2	0	12	1	4	7	-1	150	155	4
10																													

Table D-4

Continued.

h k l 10Po 10Fc 10a				h k l 10Po 10Fc 10a				h k l 10Po 10Fc 10a				h k l 10Po 10Fc 10a				h k l 10Po 10Fc 10a													
11	9	-1	26	45	25	6	0	0	398	490	4	10	7	0	0	1	3	16	0	32	37	18	1	5	1	91	89	3	
1	10	-1	149	146	4	8	0	0	230	238	3	11	7	0	49	44	13	4	16	0	110	111	8	2	5	1	441	457	5
2	16	-1	337	332	6	10	0	0	53	59	0	0	0	146	147	4	5	16	0	0	30	1	3	5	1	186	192	3	
3	19	-1	104	106	5	12	0	0	87	66	12	1	8	0	191	183	3	6	16	0	32	35	21	4	8	1	181	173	3
4	16	-1	169	169	4	1	1	0	73	62	2	2	0	0	50	82	4	7	16	0	72	85	7	5	5	1	293	281	6
5	10	-1	61	63	8	2	1	0	169	188	1	3	8	0	171	172	3	8	16	0	9	2	0	6	5	1	110	110	4
6	16	-1	42	13	10	5	1	0	1156	1210	11	4	0	0	45	45	5	1	17	0	59	66	10	7	5	1	77	93	6
7	16	-1	60	70	10	6	1	0	72	47	4	5	0	0	178	177	2	2	17	0	48	37	9	8	5	1	124	121	5
8	16	-1	102	87	7	5	1	0	196	205	2	6	0	0	72	82	4	3	17	0	30	35	23	9	5	1	161	62	8
9	10	-1	0	83	1	6	1	0	4	4	4	7	0	0	124	125	3	4	17	0	104	109	8	10	5	1	133	128	7
10	10	-1	51	42	11	7	1	0	61	61	6	8	0	0	105	100	6	5	17	0	96	89	7	11	5	1	40	59	22
0	11	-1	154	149	4	8	1	0	139	138	3	9	0	0	70	79	7	6	17	0	30	26	25	12	5	1	43	54	18
1	11	-1	27	22	11	9	1	0	7	3	6	10	0	0	47	47	11	7	17	0	61	70	7	1	6	1	60	60	5
2	11	-1	139	128	4	10	1	0	0	11	1	11	0	0	37	38	11	0	18	0	96	116	6	2	6	1	243	256	4
3	11	-1	31	31	13	11	1	0	14	14	14	1	9	0	170	176	2	1	18	0	45	45	8	3	6	1	107	99	4
4	11	-1	76	78	7	12	1	0	57	65	0	2	9	0	20	31	0	2	18	0	94	109	6	4	6	1	221	213	4
5	11	-1	153	161	5	0	2	0	320	344	7	3	9	0	59	65	4	3	18	0	75	83	7	5	6	1	231	227	4
6	11	-1	96	99	6	1	2	0	483	454	6	4	9	0	101	100	3	4	18	0	52	55	9	6	6	1	151	149	4
7	11	-1	65	58	11	2	2	0	393	423	3	5	9	0	200	279	12	5	18	0	26	19	20	7	6	1	160	156	4
8	11	-1	117	112	8	3	2	0	306	323	4	6	9	0	162	189	3	6	18	0	26	37	25	0	6	1	37	43	17
9	11	-1	20	46	28	4	2	0	271	288	4	7	9	0	80	79	4	1	19	0	22	22	22	9	6	1	16	26	15
10	11	-1	0	19	1	5	2	0	60	70	5	8	9	0	91	86	4	2	19	0	71	63	8	10	6	1	136	134	7
1	12	-1	151	140	4	8	2	0	169	179	2	9	9	0	62	64	7	3	19	0	18	24	17	11	6	1	26	17	26
2	12	-1	182	186	4	7	3	0	98	93	3	10	9	0	62	64	7	4	19	0	25	18	24	12	6	1	32	22	19
3	12	-1	169	174	4	8	2	0	176	178	4	11	9	0	33	27	14	8	19	0	0	12	1	0	7	1	226	238	4
4	12	-1	188	182	8	9	2	0	44	34	9	0	10	0	332	386	4	0	20	0	126	121	6	1	7	1	255	261	6
5	12	-1	72	70	6	10	2	0	0	7	1	1	10	0	349	348	4	1	20	0	67	59	7	2	7	1	148	146	3
6	12	-1	84	79	6	11	2	0	28	45	24	2	10	0	264	261	3	2	20	0	0	32	1	3	7	1	363	355	6
7	12	-1	140	138	7	12	2	0	71	82	6	3	10	0	89	89	4	3	20	0	5	16	5	4	7	1	142	140	4
8	12	-1	77	83	10	1	3	0	0	7	1	4	10	0	193	188	2	4	20	0	0	10	1	5	7	1	91	94	5
9	12	-1	13	36	12	2	3	0	454	489	3	5	10	0	167	171	11	1	21	0	18	6	18	6	7	1	180	168	4
10	12	-1	46	38	15	3	3	0	97	100	2	6	10	0	180	93	8	2	0	1	312	306	5	7	7	1	56	45	7
0	13	-1	156	145	4	4	3	0	99	99	6	7	10	0	173	166	3	4	0	1	450	451	5	8	7	1	65	58	7
1	13	-1	121	126	4	5	3	0	151	166	3	8	10	0	0	3	1	6	0	1	61	49	5	9	7	1	54	47	10
2	13	-1	112	108	6	6	3	0	477	508	4	9	10	0	30	32	16	8	0	1	194	190	4	10	7	1	101	102	8
3	13	-1	51	43	9	7	3	0	174	181	1	10	10	0	38	54	13	10	0	1	59	61	12	11	7	1	59	63	11
4	13	-1	0	24	1	8	3	0	152	145	3	11	10	0	0	22	1	12	0	1	74	80	9	1	8	1	127	125	3
5	13	-1	138	138	8	9	3	0	46	27	9	1	11	0	171	166	2	0	1	1	688	712	3	1	8	1	317	322	6
6	13	-1	97	99	8	10	3	0	117	117	8	2	11	0	352	345	9	1	1	1	707	685	4	3	8	1	220	211	4
7	13	-1	38	24	38	11	3	0	211	206	4	3	11	0	56	58	6	2	1	1	1345	1277	4	4	8	1	545	529	5
8	13	-1	21	3	20	12	3	0	83	83	8	4	11	0	218	211	3	3	1	1	249	251	4	5	8	1	73	64	6
9	13	-1	127	119	6	0	4	0	862	913	3	5	11	0	0	4	1	4	1	1	258	270	6	6	0	1	193	188	4
1	14	-1	72	78	7	1	4	0	18	38	18	6	11	0	91	89	4	5	1	1	138	132	3	7	8	1	134	137	4
2	14	-1	25	26	25	2	4	0	385	409	4	7	11	0	62	45	5	6	1	1	388	387	6	0	0	1	0	10	1
3	14	-1	26	15	24	3	4	0	208	209	3	8	11	0	29	30	13	7	1	1	38	46	12	9	0	1	7	12	6
4	14	-1	52	38	10	4	4	0	476	498	4	9	11	0	72	81	7	8	1	1	41	21	12	10	8	1	94	77	8
5	14	-1	58	60	17	5	4	0	77	79	3	10	11	0	123	118	10	9	1	1	133	130	4	11	8	1	8	15	1
6	14	-1	47	76	23	6	4	0	89	93	4	0	12	0	117	109	3	10	1	1	157	148	7	0	9	1	284	280	6
7	14	-1	41	35	15	7	4	0	116	104	3	1	12	0	50	55	5	11	1	1	66	62	14	1	9	1	268	262	6
8	14	-1	45	43	13	8	4	0	90	94	4	2	12	0	6	15	6	12	1	1	37	38	18	2	9	1	283	291	6
9	14	-1	3	8	3	9	4	0	19	25	19	3	12	0	167	164	3	1	2	1	1049	1032	4	3	9	1	121	136	0
0	15	-1	4	51	1	10	4	0	91	102	6	4	12	0	26	30	13	2	2	1	220	229	3	4	9	1	119	125	5
1	15	-1	137	124	5	11	4	0	62	27	19	5	12	0	141	122	5	3	2	1	910	890	5	5	9	1	32	43	17
2	15	-1	188	96	6	12	4	0	6	27	6	6	12	0	28	23	12	4	2	1	164	176	3	6	9	1	68	72	8
3	15	-1	168	161	4	1	5	0	767	801	3	7	12	0	146	134	4	5	2	1	588	505	5	7	9	1	121	107	5
4	15	-1	60	65	13	2	5	0	694	724	5	8	12	0	45	54	13	6	2	1	107	110	5	8	9	1	29	15	29
5	15	-1	184	185	7	3	5	0	380	371	4	9	12	0	28	36	24	7	2	1	148	150	4	9	9	1	88	70	7
6	15	-1	22	50	31	4	5	0	189	180	3	10	12	0	30	38	15	8	2	1	146	148	4	10	9	1	41	23	20
7	15	-1	75	72	10	5	5	0	223	232	3	1	13	0	91	48	8	9	2	1	126	124	8	11	9	1	40	47	22
8	15	-1	0	19	1	6	5	0	82	85	5	2	13	0	18	19	18												

Table D-4

Continued.

h	k	l	10Po	10Pe	10e	h	k	l	10Po	10Pe	10e	h	k	l	10Po	10Pe	10e	h	k	l	10Po	10Pe	10e	h	k	l	10Po	10Pe	10e
8	13	1	86	78	8	4	2	2	431	413	6	9	9	3	26	22	23	1	20	2	33	41	21	11	7	3	19	24	19
9	13	1	26	30	25	5	3	2	327	323	4	10	9	2	37	38	25	2	20	2	49	58	10	1	8	3	382	297	6
10	13	1	28	33	15	6	2	2	91	88	5	11	9	2	34	42	15	3	20	3	23	13	22	2	8	3	215	219	4
0	13	1	150	144	4	7	2	2	120	116	4	0	10	1	196	199	3	2	0	3	271	262	6	3	0	3	172	176	4
1	13	1	141	133	4	8	2	2	46	46	10	1	10	2	169	169	4	4	0	3	590	566	8	4	0	3	213	229	4
2	13	1	127	107	4	9	2	2	147	162	4	2	10	2	170	175	4	6	0	3	194	193	4	5	0	3	107	105	5
3	13	1	26	43	25	10	2	2	32	40	31	3	10	2	78	75	6	8	0	3	185	185	5	6	0	3	151	148	4
4	13	1	26	28	28	11	2	2	38	33	24	4	10	2	69	53	8	10	0	3	181	98	7	7	0	3	34	30	13
5	13	1	141	136	5	12	2	2	36	50	26	5	10	2	0	20	1	0	1	3	199	206	3	8	0	3	119	115	7
6	13	1	105	97	8	1	3	2	488	486	8	6	10	2	101	99	5	1	1	3	520	525	5	9	0	3	24	21	23
7	13	1	34	31	34	2	1	2	766	788	5	7	10	2	189	179	6	2	1	3	99	98	3	10	0	3	30	30	20
8	13	1	0	6	1	3	3	2	134	133	3	8	10	2	164	118	0	3	1	3	167	104	4	0	9	3	54	55	7
9	13	1	119	110	8	4	3	2	517	503	5	9	10	2	19	8	19	4	1	3	58	58	6	1	9	3	118	120	4
1	14	1	93	89	6	5	3	2	127	132	4	10	10	2	32	40	24	5	1	3	184	184	4	2	9	3	192	195	3
2	14	1	48	31	8	6	3	2	262	263	6	1	11	2	122	115	4	6	1	3	49	40	7	3	9	3	122	119	5
3	14	1	40	27	9	7	2	2	191	160	4	2	11	2	89	72	6	7	1	3	179	174	4	4	9	3	41	35	12
4	14	1	42	36	11	8	2	2	183	176	4	3	11	2	119	120	5	8	1	3	91	87	6	5	9	3	44	51	10
5	14	1	66	60	10	9	3	2	158	160	4	4	11	2	66	63	0	9	1	3	138	128	6	6	0	3	284	287	6
6	14	1	92	72	10	10	3	2	45	75	11	5	11	2	148	152	4	10	1	3	8	16	7	7	9	3	44	38	12
7	14	1	44	32	15	11	3	2	48	64	26	6	11	2	93	95	6	11	1	3	49	42	11	8	9	3	164	162	6
8	14	1	29	41	29	12	3	2	44	82	18	7	11	2	77	80	10	1	2	3	282	282	5	9	9	3	0	16	6
9	14	1	0	9	1	6	4	2	643	665	5	8	11	2	182	73	9	2	2	3	488	467	5	10	9	3	17	27	17
0	15	1	44	89	12	1	4	2	784	747	5	9	11	2	32	10	21	3	2	3	212	211	4	1	20	3	98	99	7
1	15	1	119	117	5	2	4	2	344	307	4	10	11	2	23	19	22	4	2	3	689	434	6	2	18	3	184	179	3
2	15	1	99	96	8	3	4	2	287	288	6	0	12	2	162	187	4	5	2	3	66	49	10	3	10	3	69	71	8
3	15	1	164	168	4	4	4	2	198	185	3	1	12	2	183	98	5	4	2	3	29	26	17	4	18	3	188	187	4
4	15	1	84	64	18	5	4	2	232	237	4	2	12	2	32	60	24	7	2	2	72	69	7	5	10	3	81	83	4
5	15	1	197	194	9	6	4	2	158	126	4	3	12	2	49	52	9	8	2	3	67	68	6	6	10	3	166	154	4
6	15	1	29	48	20	7	4	2	278	226	4	4	12	2	121	116	5	9	2	3	133	116	6	7	10	3	94	98	10
7	15	1	69	69	18	8	4	2	157	151	5	5	12	2	188	87	6	10	2	3	60	62	15	8	10	3	84	93	11
8	15	1	34	20	24	9	4	2	147	143	6	6	12	2	48	48	16	11	2	3	56	42	11	9	10	3	24	24	24
9	15	1	83	84	13	10	4	2	34	59	23	7	12	2	19	26	18	0	3	3	321	324	6	10	10	3	0	9	1
0	16	1	101	102	9	11	4	2	97	66	26	8	12	2	43	72	15	1	3	3	207	226	4	0	11	3	123	117	4
1	16	1	167	145	7	12	4	2	84	78	7	9	12	2	89	48	14	2	3	3	120	127	4	1	11	3	119	109	4
2	16	1	78	59	11	1	5	2	368	385	5	10	12	2	26	39	26	3	3	3	328	147	6	2	11	3	116	106	4
3	16	1	95	97	10	2	5	2	83	89	4	1	13	2	181	186	4	4	3	3	243	236	4	3	11	3	84	75	6
4	16	1	54	49	15	3	5	2	146	187	4	2	13	2	143	126	5	5	3	3	154	144	4	4	11	3	7	42	6
5	16	1	18	21	14	4	5	2	138	143	4	3	13	2	105	100	5	6	3	3	242	233	4	5	11	3	174	174	4
6	16	1	15	19	15	5	5	2	121	123	4	4	13	2	81	77	6	7	3	3	187	102	5	6	11	3	95	97	8
7	16	1	112	110	8	6	5	2	178	179	4	5	13	2	130	135	7	8	3	3	0	30	1	7	11	3	99	95	7
8	16	1	35	59	34	7	5	2	129	124	4	6	13	2	189	146	7	9	3	3	57	54	10	8	11	3	41	13	11
9	16	1	67	72	12	8	5	2	178	187	4	7	13	2	69	74	11	10	3	3	0	26	1	9	11	3	17	25	17
0	17	1	86	76	8	9	5	2	48	49	13	8	13	2	52	49	11	11	3	3	28	48	27	1	12	3	188	184	4
1	17	1	43	45	21	10	5	2	94	183	9	9	13	2	40	41	13	1	4	3	76	79	4	2	12	3	136	131	5
2	17	1	39	38	12	11	5	2	20	33	15	0	14	2	182	177	4	2	4	3	69	68	4	3	12	3	235	222	4
3	17	1	19	19	10	0	6	2	99	100	3	1	14	2	48	43	11	3	4	3	527	528	5	4	12	3	182	176	4
4	17	1	12	11	12	1	6	2	573	595	5	2	14	2	143	127	4	4	4	3	253	240	4	5	12	3	66	71	13
5	17	1	24	24	24	2	6	2	114	138	4	3	14	2	31	26	18	5	4	3	184	188	4	6	12	3	42	48	15
6	17	1	0	32	1	3	6	2	188	181	5	4	14	2	73	67	13	6	4	3	134	129	4	7	12	3	15	22	14
7	17	1	34	47	21	4	6	2	52	59	11	5	14	2	28	47	20	7	4	3	42	38	7	8	12	3	43	39	17
8	17	1	14	14	1	5	6	2	156	150	4	6	14	2	155	149	7	8	4	3	117	106	5	9	12	3	23	23	23
9	17	1	16	29	15	6	6	2	88	72	5	7	14	2	24	47	24	9	4	3	66	47	23	0	13	3	174	160	4
0	18	1	0	19	1	7	6	2	99	97	5	8	14	2	0	11	1	10	4	3	69	62	12	1	13	3	109	115	4
1	18	1	160	143	7	8	6	2	113	112	5	9	14	2	39	43	15	11	4	3	24	15	22	2	13	3	39	54	10
2	18	1	32	48	11	9	6	2	188	188	6	1	15	2	52	96	5	0	5	3	437	447	6	3	13	3	36	38	11
3	18	1	46	55	12	10	6	2	76	69	8	2	15	2	18	33	18	1	5	3	228	217	4	4	13	3	185	174	6
4	18	1	46	55	12	11	6	2	35	27	16	3	15	2	132	107	6	2	5	3	416	416	6	5	13	3	71	87	9
5	18	1	0	22	1	1	7	2	381	396	6	4	15	2	97	93	7	3	5	3	287	287	4	6	13	3	63	58	10
6	18	1	8	22	7	2	7	2	246	246	6	5	15	2	75	78	10	4	5	3	211	209	3						

Table D-4

Continued.

h	k	l	10Po	10Po	10e	h	k	l	10Po	10Po	10e	h	k	l	10Po	10Po	10e	h	k	l	10Po	10Po	10e
5	17	3	0	30	1	6	7	4	97	97	5	8	0	5	0	4	1	6	9	5	137	131	7
6	17	3	27	20	26	7	7	4	107	103	7	10	0	5	84	81	6	7	9	5	10	43	30
1	18	3	0	40	1	8	7	4	21	32	21	0	1	5	40	63	6	8	9	5	39	52	14
2	18	3	81	72	10	9	7	4	28	42	24	1	1	5	110	106	4	1	10	5	42	52	12
3	18	3	81	87	8	10	7	4	43	51	13	2	1	5	95	89	5	2	10	5	24	26	25
4	18	3	32	42	27	0	8	4	130	132	4	3	1	5	20	9	19	3	10	5	84	99	10
5	18	3	18	20	9	1	8	4	61	62	8	4	1	5	69	67	6	4	10	5	41	39	17
0	19	3	55	66	19	2	8	4	48	59	8	5	1	5	67	70	6	5	10	5	58	53	11
1	19	3	69	68	12	3	8	4	200	194	4	6	1	5	61	59	6	6	10	5	24	64	24
2	19	3	26	10	19	4	8	4	80	68	11	7	1	5	37	28	16	7	10	5	70	55	7
3	19	3	23	7	23	5	8	4	53	44	8	8	1	5	47	66	19	8	10	5	56	44	10
0	0	4	290	316	6	6	8	4	99	101	7	9	1	5	27	40	27	0	11	5	114	114	9
2	0	4	285	280	6	7	8	4	111	112	7	10	1	5	0	26	1	1	11	5	36	52	22
4	0	4	63	54	5	8	8	4	104	98	6	1	2	5	154	147	4	2	11	5	48	65	22
6	0	4	185	181	4	9	8	4	38	38	19	2	2	5	133	128	4	3	11	5	65	74	19
8	0	4	200	186	6	10	8	4	57	39	9	3	2	5	133	128	4	4	11	5	94	89	7
10	0	4	81	50	13	1	9	4	114	109	5	4	2	5	82	69	5	5	11	5	0	26	8
1	1	4	283	284	6	2	9	4	48	41	8	5	2	5	133	128	5	6	11	5	56	47	9
2	1	4	171	171	3	3	9	4	127	128	9	6	2	5	0	2	1	7	11	5	17	16	17
3	1	4	71	74	6	4	9	4	167	151	4	7	2	5	33	29	17	1	12	5	26	25	26
4	1	4	228	234	4	5	9	4	107	102	5	8	2	5	65	49	9	2	12	5	97	90	9
5	1	4	87	89	9	6	9	4	142	141	7	9	2	5	45	46	12	3	12	5	38	49	38
6	1	4	67	49	4	7	9	4	35	33	24	10	2	5	43	40	12	4	12	5	86	64	16
7	1	4	37	32	11	8	9	4	11	20	11	9	3	5	144	139	4	5	12	5	0	7	1
8	1	4	136	124	7	9	9	4	62	51	9	1	3	5	184	180	4	6	12	5	28	31	28
9	1	4	53	46	11	0	10	4	125	135	4	2	3	5	155	148	4	0	13	5	42	46	16
10	1	4	27	47	28	1	10	4	82	97	6	3	3	5	84	88	8	1	13	5	67	86	12
11	1	4	45	34	16	2	10	4	47	38	13	4	3	5	112	107	4	2	13	5	0	38	1
0	2	4	315	312	6	3	10	4	69	73	9	5	3	5	11	17	18	3	13	5	35	40	20
1	2	4	195	193	3	4	10	4	128	129	5	6	3	5	169	155	5	4	13	5	12	52	13
2	2	4	248	242	4	5	10	4	74	77	14	7	3	5	81	86	9	5	13	5	48	41	10
3	2	4	284	275	6	6	10	4	164	162	6	8	3	5	26	44	26	1	14	5	5	34	4
4	2	4	148	149	3	7	10	4	80	79	12	9	3	5	0	28	1	2	16	5	0	39	1
5	2	4	44	55	9	8	10	4	68	68	12	10	3	5	15	30	15	3	16	5	24	41	25
6	2	4	44	37	9	9	10	4	0	17	1	1	4	5	124	126	4	4	16	5	69	61	9
7	2	4	112	109	5	1	11	4	188	182	4	2	4	5	118	106	4	0	15	5	0	20	1
8	2	4	30	37	29	2	11	4	166	162	4	3	4	5	243	228	6	1	15	5	25	50	25
9	2	4	182	91	7	3	11	4	188	187	4	4	4	5	147	142	4	2	15	5	0	30	1
10	2	4	25	17	28	4	11	4	20	36	19	5	4	5	24	35	23	3	15	5	0	22	1
11	2	4	45	45	12	5	11	4	84	85	23	6	4	5	0	35	1	1	16	5	0	24	1
1	3	4	220	230	4	6	11	4	27	18	27	7	4	5	26	13	28	0	17	5	0	21	1
2	3	4	294	213	3	7	11	4	24	23	23	8	4	5	47	26	11	0	0	6	75	76	6
3	3	4	276	263	6	8	11	4	72	77	7	9	4	5	42	37	11	2	0	6	97	89	5
4	3	4	132	128	4	9	11	4	30	8	23	10	4	5	19	10	18	4	0	6	69	73	11
5	3	4	112	108	4	0	12	4	99	91	5	0	5	5	197	192	4	6	0	6	80	79	8
6	3	4	123	113	4	1	12	4	158	152	4	1	5	5	178	181	4	8	0	6	36	21	21
7	3	4	83	85	8	2	12	4	28	39	27	2	5	5	140	141	4	1	1	6	137	128	4
8	3	4	14	23	14	3	12	4	98	83	18	3	5	5	52	39	7	2	1	6	134	126	5
9	3	4	62	67	9	4	12	4	95	73	11	4	5	5	157	148	4	3	1	6	112	108	4
10	3	4	58	54	11	5	12	4	0	34	1	5	5	5	104	105	5	4	1	6	92	94	8
11	3	4	0	26	1	6	12	4	78	85	9	6	5	5	174	173	5	5	1	6	82	82	13
0	4	4	268	268	4	7	12	4	28	28	28	7	5	5	33	12	22	6	1	6	95	95	12
1	4	4	121	122	4	8	12	4	28	28	26	8	1	6	128	118	6	7	1	6	48	52	18
2	4	4	126	124	4	9	12	4	12	38	11	9	5	5	89	87	10	8	1	6	19	21	18
3	4	4	189	187	4	1	13	4	64	64	19	1	6	5	93	100	5	9	1	6	18	11	18
4	4	4	223	228	4	2	13	4	75	84	9	2	6	5	204	192	4	0	2	6	168	161	4
5	4	4	162	172	4	3	13	4	16	10	15	3	6	5	96	98	5	1	2	6	150	144	4
6	4	4	138	131	4	4	13	4	181	99	7	4	6	5	84	77	5	2	2	6	62	62	8
7	4	4	174	166	4	5	13	4	25	29	24	5	6	5	281	281	5	3	2	6	107	94	5
8	4	4	122	127	7	7	13	4	22	13	21	6	6	5	116	92	6	4	2	6	24	37	23
9	4	4	37	53	27	8	13	4	0	7	1	7	6	5	51	57	16	5	2	6	133	121	4
10	4	4	48	46	13	9	14	4	44	74	22	8	6	5	0	26	1	6	2	6	79	68	8
1	5	4	189	195	3	1	14	4	81	87	9	9	6	5	26	35	26	7	2	6	68	46	9
2	5	4	152	143	4	2	14	4	65	59	14	0	7	5	149	128	4	8	2	6	0	25	1
3	5	4	0	9	1	3	14	4	88	61	14	1	7	5	22	22	31	1	3	6	60	60	8
4	5	4	126	129	4	4	14	4	104	97	8	2	7	5	122	122	5	2	3	6	149	145	4
5	5	4	0	4	1	5	14	4	28	24	24	3	7	5	84	77	5	3	3	6	108	98	5
6	5	4	138	135	4	6	14	4	96	86	9	4	7	5	117	115	5	4	3	6	209	200	5
7	5	4	144	129	6	7	14	4	0	9	1	5	7	5	25	23	25	5	3	6	112	110	7
8	5	4	97	84	0	1	15	4	29	64	20	6	7	5	168	168	6	6	3	6	34	32	18
9	5	4	42	21	18	2	15	4	62	86	24	7	7	5	91	89	18	7	3	6	59	50	11
10	5	4	0	17	1	3	15	4	88	78	8	8	7	5	42	39	12	8	3	6	31	77	31
0	6	4	480	470	6	4	16	4	67	64	9	9	7	5	68	59	8	0	4	6	43	56	18
1	6	4	258	243	6	5	16	4	73	66	9	1	8	5	65	88	8	1	4	6	28	21	20
2	6	4	150	137	4	6	16	4	20	32	19	2	8	5	39	43	11	2	4	6	133		

Table D-4**Continued.**

h	k	l	10Fe	10Fe	10s	h	k	l	10Fe	10Fe	10s	h	k	l	10Fe	10Fe	10s	h	k	l	10Fe	10Fe	10s	h	k	l	10Fe	10Fe	10s																																																																																																																																																																																																																																																																								
4	6	7	28	37	28	2	8	7	33	33	33	2	0	8	66	73	10	4	2	8	42	13	10	1	5	8	0	8	1	5	6	7	81	90	7	3	8	7	39	41	22	4	0	8	23	45	22	1	3	8	0	4	1	2	5	8	0	28	1	6	6	7	46	43	11	4	8	7	0	31	1	1	1	8	17	24	17	2	3	8	13	42	13	3	5	8	17	9	17	0	7	7	124	116	7	0	9	7	36	63	19	2	1	8	24	39	24	3	1	8	26	27	26	0	6	8	0	48	1	1	7	7	0	34	1	1	9	7	19	61	19	3	1	8	32	13	18	4	3	8	34	57	33	1	6	8	0	10	1	2	7	7	20	26	19	2	9	7	63	70	10	4	1	8	21	57	20	0	4	8	28	38	27	2	6	8	0	37	1	3	7	7	24	50	24	3	9	7	61	69	11	0	2	8	0	29	1	1	4	8	9	26	9	3	6	8	24	13	23	4	7	7	59	50	10	1	10	7	16	27	16	1	2	8	93	96	8	2	4	8	9	26	9	1	7	8	29	27	28	5	7	7	24	23	23	0	11	7	65	74	12	2	2	8	47	62	15	3	4	8	17	33	17	2	7	8	16	6	15	1	8	7	0	50	1	0	0	8	139	120	6	3	2	8	25	40	25	4	4	8	31	56	31

