

**Two-Dimensional Agarose Gel Analysis of Branched Double-Stranded and Partially  
Single Stranded Synthetic DNA Constructs**

by

An'trese Critchlow-Wood

Submitted in Partial Fulfillment of the Requirements

for the Degree of

Master of Science

in the

Biological Sciences

Program

YOUNGSTOWN STATE UNIVERSITY

August, 2000

**TWO-DIMENSIONAL AGAROSE GEL ANALYSIS OF BRANCHED  
DOUBLE-STRANDED AND PARTIALLY SINGLE STRANDED  
SYNTHETIC DNA CONSTRUCTS**

An'trese Critchlow-Wood

I hereby release this thesis to the public. I understand this thesis will be housed at the Circulation Desk of the University Library and will be available for public access. I also authorize the University or other individuals to make copies of this thesis as needed for scholarly research.

Signature:

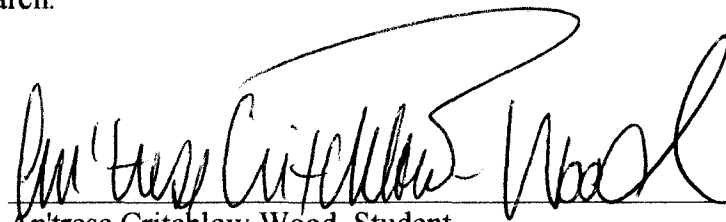
  
An'trese Critchlow-Wood, Student 7.27.00  
Date

Approvals:

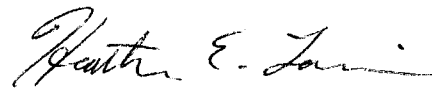
  
Heather E. Lorimer, Thesis Advisor 7/27/00  
Date

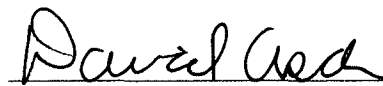
  
David Asch, Committee Member 7/27/00  
Date

  
Gary Walker, Committee Member 7/27/00  
Date

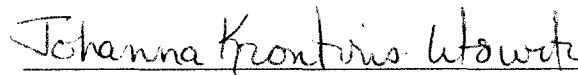
  
Johanna Krontiris-Litowitz, Committee Member 7/27/00  
Date

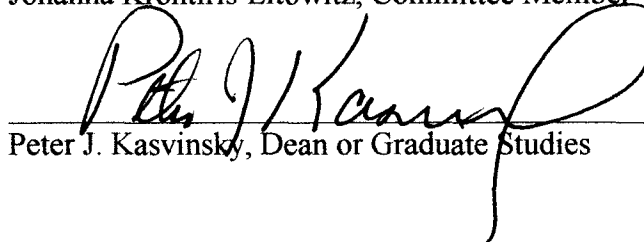
  
Peter J. Kasvinsky, Dean of Graduate Studies 7/31/00  
Date

## ABSTRACT

In the late 1980's, a link was established between mutations in human mitochondrial DNA (mtDNA) and certain human diseases which affect neural and muscle tissue. Individuals who have mtDNA diseases have both normal and mutant mtDNA. Increasing severity of the disease is correlated with an increase in the proportion of mutant mtDNA.

To understand the abnormal mtDNA processes which cause disease, we must first be able to understand normal mtDNA processes which haven't been entirely elucidated. Today, the most widely accepted model of mammalian mtDNA replication is the D-loop model. The proposed asynchronous and asymmetrical D-loop model should produce regions of single stranded DNA bound to double stranded DNA. Recently, mouse and human mtDNA were analyzed by Brewer/Fangman two-dimensional agarose gel electrophoresis. Replication forms were seen which had characteristics predicted for partially single stranded D-loop DNA. However, DNA forms which are known to be partially single stranded have not been analyzed.

My research involved the formation of partially single stranded DNA constructs which can be used as reference points for how D-loop replication intermediates should run on 2-D gels. Synthetic partially single stranded DNA constructs were compared with normal double stranded and single stranded total cellular mtDNA. The constructs migrated between the double stranded and single stranded arcs, as might be predicted as the constructs are neither totally single stranded nor double stranded. In the future, other forms expected by the D-loop model and alternate bi-directional synthesis may be synthesized which include double stranded Y arc constructs, whole and partially single stranded D-loop constructs, and other sizes of branched structures with one single stranded arm which may provide further insight into normal mammalian mtDNA replication processes.

## ACKNOWLEDGMENTS

I would like to express my thanks to the Biology Department at Youngstown State University for providing me with a two year Graduate Assistantship and also for equipment and supplies for this research.

I would like to extend much thanks and gratitude to Dr. Heather Lorimer, my thesis advisor, for her time, patience, availability, and aiding in the critical review of this thesis. I also wish to thank Dr. David Asch and Dr. Gary Walker for their advice and the use of their respective labs. I would also like to acknowledge Dr. Johanna Krontiris-Litowitz for her time as a member of my thesis committee.

Finally, I would like to thank my husband, Christopher Wood, for his love, patience, support, and computer expertise without which I'm not sure my goals would have come to fruition. I would also like to thank my family and friends for their continued support of my academic goals over the past three years and for the years to come.

## TABLE OF CONTENTS

	Page
ABSTRACT.....	iii
ACKNOWLEDGMENTS.....	iv
TABLE OF CONTENTS.....	v
LIST OF FIGURES.....	vii
INTRODUCTION.....	1
I. Specific Aims.....	1
II. Significance.....	2
III. Background.....	7
METHODS.....	14
Experimental Design.....	14
I. Preparation and Isolation of Plasmid DNA.....	16
II. Isolating DNA Fragments.....	19
III. Formation of Artificial DNA Constructs.....	22
IV. Analysis of Synthetic DNA Constructs.....	22
V. Radioactive Probes/Hybridization.....	24
RESULTS.....	27
I. Isolation of 281 base pair pHS3324 fragment and 686 bp pN28 fragment.....	27
II. Isolation of single stranded plasmid DNA through the use of a 6.0% acrylamide gel.....	27
III. Assembly of the partially single stranded and double stranded synthetic DNA constructs.....	32

**TABLE OF CONTENTS, continued**

IV. Analysis of the partially single stranded and double stranded DNA constructs with yeast total cellular pHS3324 DNA through the use of a Neutral-Neutral Two-Dimensional Agarose Gel.....	33
V. Analysis of synthetic partially single stranded and double stranded DNA constructs without yeast total cellular pHS3324 DNA through the use of a Neutral-Neutral Two-Dimensional Agarose Gel.....	36
DISCUSSION.....	40
WORKS CITED.....	46

## LIST OF FIGURES

	Page
1. Map of human mitochondrial genome.....	5
2. D-loop model of mammalian mtDNA replication.....	8
3. Map of human mitochondrial genome with emphasis on the D-loop region.....	9
4. The formation of an RNA-DNA hybrid.....	11
5. The yeast mitochondrial genome map.....	15
6. The pUC based plasmids pHS3324 and pN28.....	28
7. The double stranded 281 bp fragment isolated from pHS3324 and the double stranded 686 bp fragment isolated from pN28.....	29
8. A 1.2% agarose gel of pHS3324 cut with HaeII and HindIII and pN28 cut with HaeII and BclI.....	30
9. A 6.0% acrylamide gel of denatured double stranded 281 bp fragment of pHS3324.....	31
10. Typical 2-D gel patterns generated by the three basic forms of classical bi-directional semi-conservative replication intermediates.....	34
11. First dimension of a 2-D gel.....	35
12. Autoradiogram of second dimension of a 2-D gel.....	37
13. Autoradiogram of second dimension of a 2-D gel.....	39
14. Autoradiogram of total cellular mitochondrial DNA.....	41
15. Synthetic double stranded constructs and partially single stranded constructs with varying sizes of branched arms that still need to be made.....	45

## INTRODUCTION

### *I. Specific Aims*

The proposed asynchronous and asymmetrical D-loop model of mammalian mitochondrial DNA (mtDNA) replication suggests that replication begins from two origins- a heavy (H) strand origin ( $O_H$ ) and a light (L) strand origin ( $O_L$ ) (reviewed in Schmitt and Clayton 1993). According to the D-loop model, replication begins at  $O_H$  and continues unidirectionally along the parental L-strand to synthesize a full circle of mtDNA (Xu and Clayton 1996). The  $O_L$  begins replication when elongation of the nascent H-strand is about two-thirds complete. At this point, the  $O_L$  is exposed as a single stranded region and presumably forms a secondary structure recognized by a specific primase. Hence, the  $O_H$  is defined as the leading strand origin, while the  $O_L$  is the lagging strand origin. The products of this D-loop model are hypothesized to be partially single stranded intermediates (Schmitt and Clayton 1993).

A substantial amount of indirect evidence supports this model, but little direct analysis of the structure of replicating mtDNA molecules has been done. In other DNA replication systems such as plasmid, viral, and nuclear chromosomal, electron microscopy and 2-D gel systems which can determine the structure of DNA replication intermediates have been used to analyze replicating forms of plasmid, viral, and nuclear DNA (Brewer et al. 1988).

Recently, the Brewer/Fangman 2-D gel electrophoresis technique was used to analyze partially single stranded mouse and human mtDNA in normal and rapidly restoring conditions (Holt et al. 2000). Replication forms were seen under normal conditions which have characteristics expected of D-Loop DNA. However, DNA forms which are known to be partially single stranded have not been analyzed. Therefore, I constructed partially single stranded forms to analyze. The constructs will be used as



reference points for how D-loop replication intermediates should run on gels. These artificial constructs synthesized from pUC based plasmid DNA-more specifically, pHS3324 and pN28, were then examined by 2-D gel electrophoresis. When the partially single stranded constructs were run on a 2-D gel system, it became possible to compare them with samples from cellular mitochondrial DNA. Also, it was possible to see how these constructs apply to the proposed D-loop model of replication of mammalian mtDNA.

## II. *Significance*

Mitochondria are subcellular organelles in which cellular respiration takes place in aerobic tissues. Mitochondria generate energy via oxidative phosphorylation. When respiratory chain dysfunction occurs, signs and symptoms of disease are quick to follow mainly due to insufficient energy. In humans, problems with mtDNA generally effect high energy usage tissues like neural and muscle tissue. The clinical effects of the disease depend on the degree of the particular enzyme deficiency and the specific tissues that are affected. MtDNA diseases are extremely variable due to the genetics of mtDNA and the unique pathogenesis of the mtDNA disorders (reviewed in Chomyn 1998). Currently, not much is known about the relationship between phenotype and genotype with respect to mtDNA diseases.

One reason why mtDNA diseases are variable can be attributed to the nature of the mtDNA itself. Mitochondria contain their own DNA and carry out their own replication, transcription, and translation. There are thousands of copies of mtDNA in every nucleated mammalian cell. The proportion of mutant mtDNA in any cell or tissue can vary from 0% to 100% (reviewed in Poulton 1996). The level of mutant mtDNA is critical in determining which tissue is involved and how the disease evolves. In normal

individuals, essentially all of the mtDNA present are identical- this is referred to as homoplasmy. Individuals who have mtDNA diseases have heteroplasmic mtDNA. Heteroplasmy is the presence of both normal and mutant mtDNA in a single individual. Mammals require respiration, so they can't ever be entirely homoplasmic for defective mtDNA. Cell lines which are heteroplasmic either exhibit an unstable or a stable genotype depending on the type of mutation and the ratio of the pure mutant genotype to the wild type genotype (reviewed in Yoneda et al. 1992). Unstable heteroplasmic cell lines exhibit a dramatic shift towards the pure mutant genotype. The shifts were attributed to increased relative replication of mutant mtDNA. Changing levels of mtDNA in patients suffering from mtDNA diseases may explain some of the wide phenotypic variation found in patients who have identical DNA mutations (Poulton 1996).

There are basically two types of mtDNA mutations which cause mtDNA diseases- mtDNA rearrangements and mtDNA point mutations. The mitochondrial myopathies are a group of diseases caused by mtDNA rearrangements. They are characterized by muscle weakness along with abnormal muscle histology (Poulton 1996). The mitochondrial myopathies have a characteristic massive proliferation of mitochondria which clump together in abnormal muscle cells. When these abnormal muscle cells are stained with Gomori's modified trichrome stain, the clump of mitochondria give off a characteristic "ragged red" appearance (reviewed in Chomyn 1998). However, the characteristic ragged red appearance may not be visible in the early stages of the disease. While the mitochondrial myopathies mainly affect muscle, they may have profound effects on the brain, eyes, heart, endocrine organs, liver, kidney, pancreas, and blood.

The three most well known mitochondrial myopathies are Kearns-Sayre Syndrome (KSS), chronic progressive external ophthalmoplegia (CPEO), and Pearson's Syndrome (Poulton 1996). Patients with KSS exhibit external ophthalmoplegia, retinal degeneration, cardiac conduction defects, deafness, ataxia, and sometimes diabetes. It

was discovered that many patients who had KSS also had several related and rearranged mtDNAs (reviewed in Poulton et al. 1993). The patients could have duplications and one or two forms of closed circular deletions- either a deletion monomer or dimer (reviewed in Griffiths et al. 1996) (Figure 1).

Individuals with Pearson's Syndrome can exhibit sideroblastic anaemia, lactic acidosis, and/or hepatic dysfunction with high levels of rearranged mtDNAs in all tissues (Poulton 1996). Patients with KSS, CPEO, and Pearson's Syndrome commonly exhibit large deletions in their mtDNA (reviewed in Holt et al. 1988).

The second type of mtDNA mutations which cause mtDNA diseases are mtDNA point mutations. The two most common mtDNA point mutations causing mitochondrial myopathy are the 3243 mutation in a tRNA (Goto et al. 1990) which is associated with MELAS (mitochondrial encephalomyopathy lactic acidosis and stroke-like episodes) and the 8344 mutation (Shoffner et al. 1990) which is associated with MERRF (myoclonic epilepsy and ragged-red fiber disease) (reviewed in Poulton 1996). Patients who have the 3243 mutation may have full blown MELAS, pure myopathy, CPEO, diabetes, deafness, or mild fatigability. The exact impact of the 3243 mutation is unclear. However, it may prevent correct mRNA processing or impair translation by either affecting the shape of the tRNA, or by incorporating incompletely processed rRNAs into mitochondrial ribosomes.

MERRF is characterized by myoclonic epilepsy, ataxia, and mitochondrial myopathy (reviewed in Chomyn 1998). It is possible for patients to exhibit atypical features such as CPEO or Leigh's Syndrome (reviewed in Poulton 1996). The MERRF point mutation occurs through an A to G transition at position 8344 in the tRNA<sup>Lys</sup> gene (reviewed in Chomyn 1998). The 8344 mutation occurs in a heteroplasmic state which means that a patient who is affected with MERRF will carry both the mutant and wild



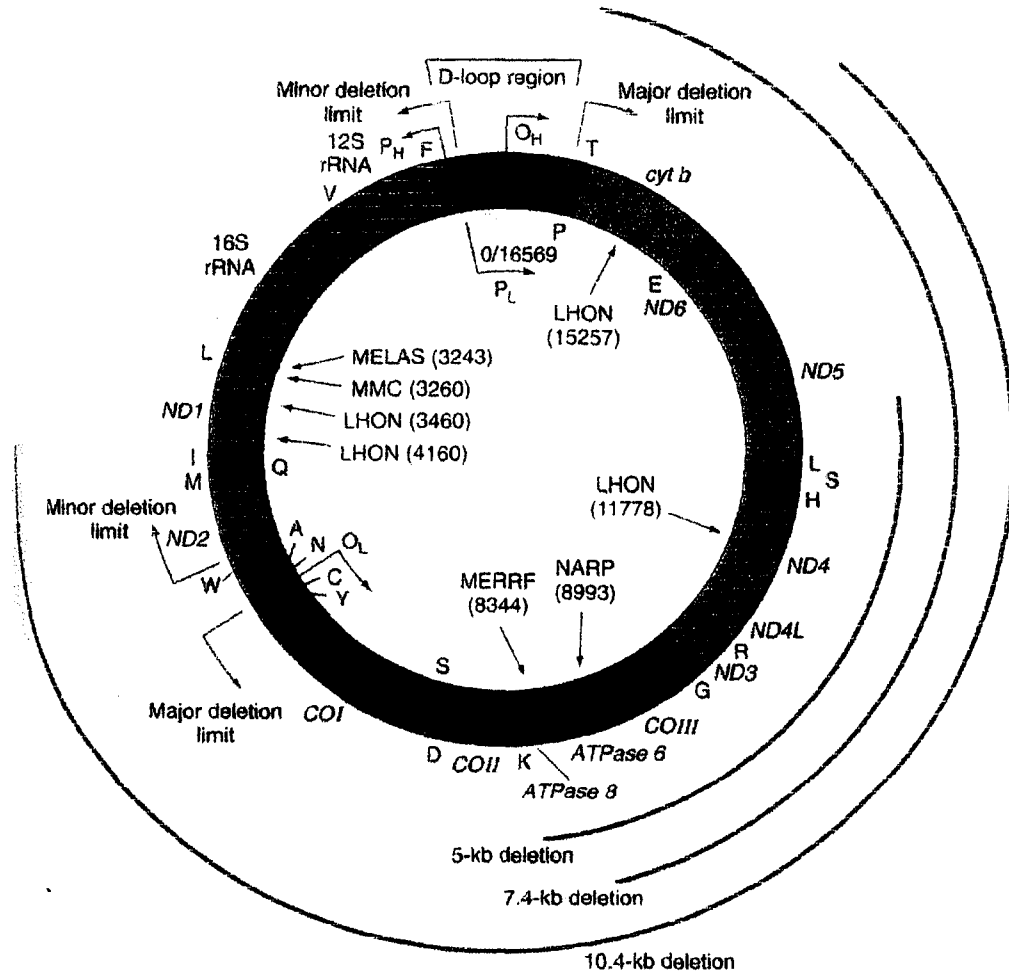

- Complex I genes (NADH dehydrogenase)
- Complex III genes (ubiquinol: cytochrome c oxidoreductase)
- Transfer RNA genes
- Complex IV genes (cytochrome c oxidase)
- Complex V genes (ATP synthase)
- Ribosomal RNA genes

O<sub>H</sub> and O<sub>L</sub> Replication origins on the H and L mtDNA strands  
 P<sub>H</sub> and P<sub>L</sub> Promoter regions

- Diseases:**
- MERRF Myoclonic epilepsy and ragged red fiber disease
  - LHON Leber's hereditary optic neuropathy
  - NARP Neurogenic muscle weakness, ataxia, and retinitis pigmentosum
  - MELAS Mitochondrial encephalomyopathy, lactic acidosis, and strokelike symptoms
  - MMC Maternally inherited myopathy and cardiomyopathy

type alleles of the gene. An expected impact of the 8344 mutation may be to bend the tRNA and cause a translational defect attributable to reduced amino acid acetylation (reviewed in Poulton 1996). Indeed, muscle biopsies were done on a number of MERRF patients and enzymological analysis revealed decreased activities of the respiratory chain enzymes (reviewed in Wallace et al. 1998). The ultimate effect of any deleterious mtDNA mutation would be the decreased production of ATP (reviewed in Chomyn 1998).

Changes in mtDNA are not only associated with specific degenerative mtDNA disease, but also with degenerative aging diseases. Over the last ten years, a number of degenerative diseases once thought to be caused by "normal" aging processes have been associated with mtDNA dysfunction or mutations. The high rate of somatic gene mutation in the mtDNA and accumulation during life contributes substantially to aging (reviewed in Linnane et al. 1989). Mutations of mtDNA are much more frequent than the rate of mutations in chromosomal DNA which is possibly due to oxidative damage and/or less extensive DNA repair mechanisms when compared to nuclear DNA. It has been suggested that tissues are made from a variety of cells which all have different mitochondrial bioenergetic capacities in which the bioenergetically deficient components increase with age. As aging occurs, it is possible to progress from Pearson's Syndrome to the more severe Kearns-Sayre Syndrome (reviewed in McShane et al. 1991). This can most likely be attributed to the mtDNA distribution changing from normal to mutant mtDNA with time (reviewed in Poulton 1996). To understand these abnormal mtDNA processes, we must first be able to understand normal mtDNA processes which haven't been entirely elucidated.

### III. *Background*

According to the D-Loop model (Figure 2), mammalian mtDNA appears to have two separate and distinct origins of replication-the heavy (H) strand and the light (L) strand (1996). The origin of the heavy strand synthesis ( $O_H$ ) is located within the displacement loop (D-loop) region of the genome (Jeong-Yu and Clayton 1996). The D-loop structure is defined as consisting of a short, nascent heavy (H) strand DNA molecule base paired to the complementary light (L) strand DNA (Schmitt and Clayton 1993). The origin of light strand synthesis ( $O_L$ ) is located within a cluster of tRNA genes which are located away from the D-loop (Figure 3) (Jeong-Yu and Clayton 1996).

In the D-loop mtDNA replication model, each of the origins of replication ( $O_H$  and  $O_L$ ) process distinct structural features that are well conserved among a variety of mammalian mtDNA species that have been examined. Initiation of heavy strand synthesis results in strand elongation the entire length of the genome (Jeong-Yu and Clayton 1996). The synthesis proceeds in a continuous and unidirectional manner which displaces the parental H strand (Schmitt and Clayton 1993). However, it is still unclear whether the elongation of the genome due to initiation of the heavy strand occurs as a continuous process or by elongation of a preexisting D-loop strand (Jeong-Yu and Clayton 1996). When two-thirds of the parental H strand has been displaced, the  $O_L$  is exposed as a single stranded entity by displacement on the Heavy (displaced) strand (Wong and Clayton 1985). The  $O_L$  is a noncoding region that is about 30 nucleotides in size. It is flanked by five tRNA genes. Replication continues in a direction opposite to that of H strand replication (Wong and Clayton 1985). The requirement for the  $O_H$  in mtDNA replication appears to be more stringent than the  $O_L$  (Jeong-Yu and Clayton 1996).





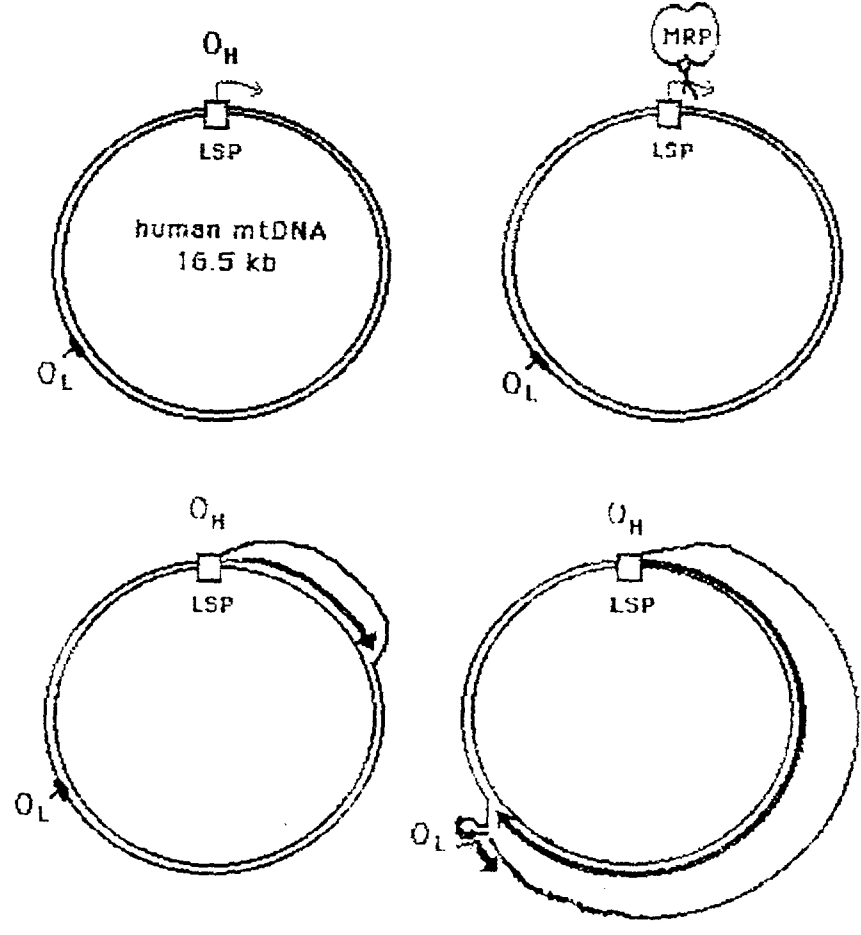



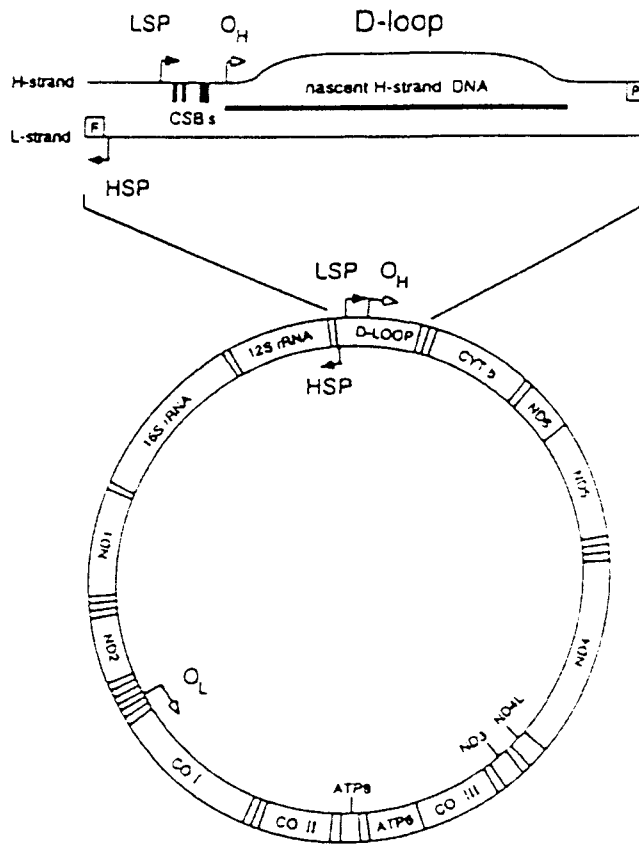

There are two promoters near the D-loop which assist with transcription initiation- the heavy strand promoter (HSP) and the light strand promoter (LSP) (Figure 2) (Jeong-Yu and Clayton 1996). The two promoters are about 150 base pairs apart and they don't overlap (Jeong-Yu and Clayton 1996). Each promoter has been found to function as complete and independent entities in in vitro assays (Jeong-Yu and Clayton 1996). The current model of mtDNA replication in mammals involves an asynchronous, asymmetric synthesis mechanism. Initiation of D-loop (leading strand) mtDNA synthesis occurs by transcription from the LSP (Jeong-Yu and Clayton 1996). A promoter produced upstream of the switch point to full DNA synthesis has been found to prime the DNA synthetic event (Jeong-Yu and Clayton 1996). An RNA-DNA hybrid was stably found at the origin sequence on the D-Loop (Figure 4) (Kogoma 1997). This RNA-DNA hybrid could be a possible substrate for site specific endoribonuclease RNase mitochondrial RNA processing perhaps by RNase MRP (Clayton 1991). A second explanation could be that a nonspecific RNase H-like enzyme could cleave an RNA sequence (Jeong-Yu and Clayton 1996). This promoter initiated primer then leads to heavy strand (leading strand) synthesis.

The exact function of the  $O_L$  is unclear. The evolutionary conservation of  $O_L$  suggests that it may play a functional role in the biosynthesis of mtDNA (Wong and Clayton 1985). As supporting evidence, the structural elements of  $O_L$  were found to be capable of directing proper initiation of mtDNA replication. The inverted repeat presumed hairpin structure of  $O_L$  may be recognized by a primase.

Replication forms from mitochondrial DNA genomes were directly examined in the yeast *Schizosaccharomyces pombe* (*S. pombe*) (reviewed in Han and Stachow 1994). *Schizosaccharomyces pombe* has a small, circular mtDNA genome which is more similar to human mtDNA than most yeast mtDNA genomes. To analyze the structure of replicating DNA the Brewer/Fangman neutral-neutral two-dimensional agarose gel



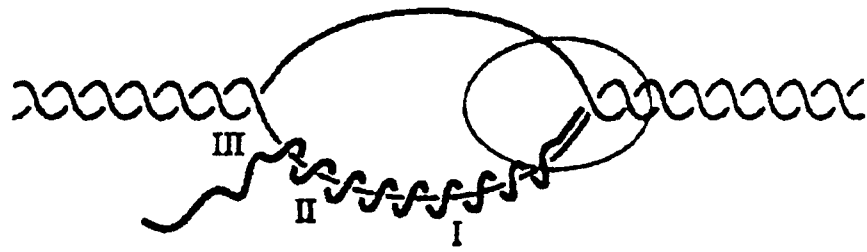

electrophoresis system was utilized (Brewer et al. 1988). Analysis of overlapping restriction fragments of the complete *S. pombe* mitochondrial genome resulted in only simple Y patterns. These simple Y patterns are not consistent with the D-loop model of replication, but rather a rolling circle mechanism indicating semi-conservative bidirectional replication with no clear origins of replication.

There is a second 2-D agarose electrophoresis technique which is called the Kevin A. Nawotka/Joel A. Huberman neutral-alkaline two dimensional gel electrophoresis system. The first dimension of the neutral alkaline method occurs when replication fork enriched DNA molecules are electrophoresed through a neutral agarose gel (Nawotka and Huberman 1988). The gel lane containing replicating DNA is rotated 90° and another gel containing a higher percentage of agarose is poured around it. The entire second dimension gel is soaked in alkaline electrophoresis buffer in order to denature the DNA. During second dimension electrophoresis, the four strands of each replicating molecule separate to produce two lines. One line is a horizontal line composed of parental strands while the second line is an arc containing nascent strands of increasing size. The DNA is transferred to a nylon membrane and is hybridized with three different probes.

Each of the 2-D gel techniques (neutral-neutral and neutral-alkaline) has technical limitations. To obtain mapping information with the alkaline technique, the membrane filters must be repeatedly reprobated with small probes (Nawotka and Huberman 1988). To be certain that an origin hasn't been missed with the neutral-neutral method, overlapping restriction fragments must be analyzed (Brewer and Fangman 1991). However, both methods rely on maintaining the parental strands in an intact or unnicked form. In the neutral-alkaline method, the hybridization signal from nascent strand arcs runs below the arc of parental strands. So with the alkaline method, the hybridization signal is subject to contaminating signal that is produced by any random single strand breaks that have

occurred in the parental strands (Nawotka and Huberman 1988). If a break were to occur in a parental strand in the neutral-neutral method, an underestimation of branched structures would occur (Brewer and Fangman 1991). We use the Brewer/Fangman 2-D gel model because it is very clean and easy to use, as well as for its effectiveness at differentiating structure.



## METHODS

### *Experimental Design*

To make the partially single stranded constructs plasmid DNA was used. Two pUC based plasmids were chosen- pHS3324 and pN28. HS3324 and N28 are known non-overlapping deletion mutants of yeast mtDNA containing small pieces of the original mtDNA genome (reviewed in Lorimer et al. 1995) (Figure 5). This allowed molecules to be produced with identical pUC sequences and different inserts. First, large quantities of plasmid DNA were made. Next, a method for isolating single stranded DNA was developed. Third, the partially single stranded constructs were assembled. Finally, the constructs were run on a neutral-neutral 2-D gel and compared to partially single-stranded mammalian mtDNA replication intermediates expected by the D-Loop Model.

### **Objectives:**

1. Prepare large quantities of plasmid DNA containing identical and non-identical regions.
2. Isolate single-stranded pieces of plasmid DNA through the use of an acrylamide gel technique.
3. Anneal fragments to make synthetic partially single stranded DNA constructs.
4. Analyze the synthetic partially single stranded DNA constructs by Brewer/Fangman 2-D agarose gel electrophoresis.



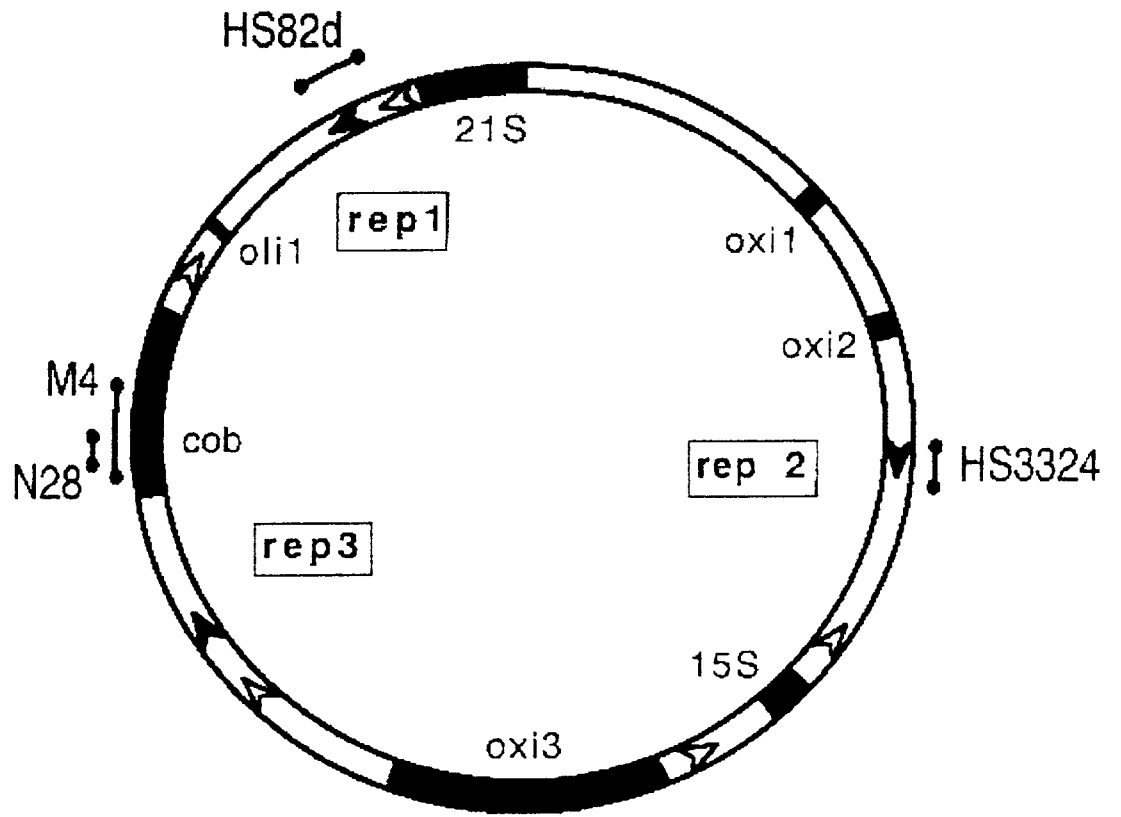

### *I. Preparation and isolation of plasmid DNA*

Bacterial E. Coli cells were transformed using preexisting plasmid DNA containing mtDNA inserts. The DNA was isolated through use of a modified Plasmid Prep procedure and/or a Plasmid Miniprep procedure.

#### *Plasmid Miniprep Procedure*

The plasmid DNA was isolated from the E. Coli cells by a modification of the plasmid miniprep procedure (Maniatis 1982). The bacterial E. Coli pellets were resuspended in 100uL of solution 1 (50mM Glucose, 10mM EDTA, and 25 mM Tris-Cl pH 8.0). The tubes were vortexed and placed on ice for one minute. Next, 200uL of solution 2 (NaOH and 1% SDS) was added to each of the tubes. SDS lyses the cells and causes DNA to be released. The tubes were inverted and placed on ice for five minutes. Next, 150uL of ice cold Solution 3 (potassium acetate and acetic acid) was added to each of the tubes. Solution 3 causes chromosomal DNA to precipitate out into the supernatant. After Solution 3 was added, the tubes were vortexed and placed on ice for five minutes. The tubes were centrifuged at 10K in the Sorvall centrifuge for five minutes. The supernatant was transferred into new tubes. A mixture containing equal amounts of phenol/chloroform was used to cleanse the plasmid DNA of any proteins or restriction enzymes.

#### *Plasmid Prep Procedure*

The plasmid prep procedure was adapted from T. Maniatis in Molecular Cloning (1982). Separation of plasmid DNA in Cesium Chloride (CsCl)-ethidium bromide gradients depends on differences in the amounts of EtBr that can be bound to linear and closed circular DNA molecules. EtBr binds to DNA by intercalating between the bases which causes the double helix to unwind. This causes an increase in the length of linear

DNA molecules and compensatory superhelical turns in closed circular plasmid DNA. Finally, the density of the superhelical turns becomes so intense that the intercalation of additional molecules of EtBr is prevented. However, linear molecules of DNA will continue to bind more dye until they become fully saturated. Hence, the densities of the linear and closed circular DNA molecules are different in CsCl gradients containing saturating amounts of EtBr due to the differential binding of EtBr.

In a sterile flask 500mL of Luria Broth, 1mL of ampicillin, and 100uL of transformed bacterial E. Coli cells were placed. The flask was incubated on a shaker at 37<sup>0</sup>C overnight. The following day, the cells were pelleted in a Sorvall centrifuge at 6K for 5 minutes at 4<sup>0</sup>C. The supernatent was discarded. The pellet was resuspended in 20mL of ice cold Solution I using a 5mL pipette. Solution I contains 50mM Glucose, 25mM Tris pH 7.5, and 10mM EDTA. Next, 40mL of Solution II was added which contains .2N NaOH and 1.0% SDS. The tube was swirled vigorously. The tube was placed on ice to incubate for 5 minutes. 20mL of ice cold Solution III was added which consists of .3 mole Potassium Acetate, 11.5mL Glacial Acetic Acid, and H<sub>2</sub>O up to 100mL mark in a flask. The tube was shaken vigorously until white granular matter appeared. The tube was placed on ice for fifteen minutes. Next, the tube was placed in the Sorvall at 6K for 5 minutes at 4<sup>0</sup>C. While the plasmid prep was spinning, 50mL of isopropanol was added to a sterile 250mL centrifuge tube. The tube was placed on ice. To remove the granular material, 4 layers of cheesecloth (approximately 3" x 3") was placed in the mouth of the tube. The supernatent from the plasmid prep was poured through the cheesecloth and the cloth was rung out. The solution was incubated on ice for 2 hours, until the precipitate consisting of nucleic acids formed, then centrifuged at 10K for 10 minutes at room temperature. The supernatent was discarded and the pellet was washed with EtOH. The pellet was allowed to dry overnight. The following day, the pellet was resuspended in 4.0 mL of 1X TE. Next, 4.65 g of CsCl was weighed to a 50mL

screw top centrifuge tube. The TE suspension containing the pellet was added. The solutions were mixed in order to dissolve the CsCl. 60uL of EtBr was added and mixed to the tube. Using Pasteur pipettes, the contents of the tube were transferred to a heat-sealed ultracentrifuge tube. The tube was placed in an NVT 65.2 rotor. The tube was centrifuged overnight at 55K and 20<sup>o</sup> C. The following day, the tube was examined to identify the supercoiled plasmid DNA band. The tube was secured in a ringstand/clamp set up with a beaker placed underneath. The upper portion of the tube was pierced with a needle to act as a vent for the tube. The side of the tube at the lower edge of the desired band was pierced with a 3mL syringe which contained a 22G I needle beveled side up. The band was extracted with the syringe and ejected into the microfuge tube. The microfuge tube was filled with a 5:1 mixture of Isopropanol:H<sub>2</sub>O. The tube was vortexed and centrifuged for 30 seconds at 15K. The upper layer was discarded in the EtBr waste. The Isopropanol:H<sub>2</sub>O extractions continued until no visible EtBr remained in either layer (EtBr is orange-pink). The aqueous layer was transferred to a corex tube. Three volumes of 70% EtOH was added. The tube was centrifuged at 10K for 20 minutes at room temperature. After, 375uL of 1X TE was added and the volume was transferred to a microfuge tube. Next, 40uL of 4M NaOAc and 1mL of 100% EtOH was added to the tube and mixed. The tube was allowed to sit out overnight for precipitate formation. The following day, the tube was centrifuged for 15 minutes at 15K in a microfuge. The supernatant was discarded and the pellet was washed with 70%EtOH. The pellet dried overnight and was dissolved in 500uL 1X TE the next day. The volume was diluted to 1/100 and the Optical Density was checked at 260nm and 280nm to determine how concentrated the DNA was.

## II. *Isolating DNA fragments*

### *Agarose Gel Electrophoresis*

Agarose gel electrophoresis is useful for separating nucleic acids and other biological molecules on the basis of size and shape. At low agarose concentrations (.6 or .8%), heavier molecules will separate out more easily. At higher agarose concentrations (1.2 or 2.0%), smaller molecules are able to separate out more easily. Also, the voltage and length of time an agarose gel is run can allow for better separation of molecules. Agarose gels that are run at lower voltages for a long length of time tend to show better separation of molecules whereas gels that are run at higher voltages for shorter amounts of time tend not to have as good a separation.

A 1.2% agarose gel electrophoresis was done to isolate double stranded pieces of plasmid DNA. In a 500mL sterile flask 3.6 grams of agarose, 240mL of sterile water, and 60mL of 5X TBE were placed. The flask was placed in the microwave on the high setting until the mixture started to boil. The flask was removed from the microwave and was swirled to make sure all the agarose had dissolved. If the agarose was not dissolved, the flask was placed in the microwave on the high setting until the mixture boiled. Again, the flask would be removed to and swirled to check that all the agarose had dissolved. Once the agarose had dissolved, the flask sat out at room temperature until its temperature reached about 50°C. Next, a large electrophoresis chamber was obtained. A comb was placed on the gel tray and the agarose mixture was poured. When the gel was set, the comb was removed and the gel tray was placed in the electrophoresis chamber. About 1600mL of 1X TBE was poured over the gel. The DNA was loaded into the appropriate wells along with 15uL of Lambda Marker which was loaded into an adjacent well. The voltage was set to 40 Volts for 12 hours.

The gel was removed from the electrophoresis chamber and was placed in a glass dish with just enough 1X TBE to cover the gel. 25uL of Ethidium Bromide (EtBr) was added and the dish was placed on a shaker for twenty minutes. Ethidium Bromide is an intercalating mutagenic dye that is able to insert itself between the bases of DNA. The EtBr allows for visualization of the DNA. When the EtBr stained gel was placed on an ultraviolet (UV) light box, the DNA was stained pink.

#### *Electrolution*

The desired DNA fragments were isolated from the gel by cutting out the strips of agarose containing visible DNA bands by using a razor blade. Each DNA band was placed in prepared dialysis bagging (Maniatis 1982) with just enough 1/2X TBE (about 200uL) to cover the band. Orange dialysis clips were used to seal the dialysis bagging. The dialysis bags that contained the DNA bands were placed in a small electrophoresis chamber with just enough 1/2X TBE to cover the dialysis bagging. The voltage was set to 100 Volts for 30 minutes. The length of time depends on the size and amount of DNA in each gel strip; the larger sizes and amounts of DNA in the gel strip the longer amount of time that is needed to isolate the DNA from the gel strip. Using a hand held UV light source, I checked to make sure all of the EtBr that was in the gel strip had migrated to the opposite end of the dialysis bag. If there was still DNA in the gel strip, the voltage was turned to 100 Volts and checked every 15 minutes after. Once the DNA had migrated from the gel strip to the opposite end of the dialysis bagging, the polarity was reversed by switching the red and black electrodes on the electrophoresis chamber for 15 seconds. This was done to insure that the negatively charged DNA would not remain attached to the dialysis bagging. Finally, using a plastic pipette the liquid containing the DNA was removed from the dialysis bags and was pipetted into sterile eppendorf tubes. The DNA was then purified from the liquid for future use.



### *Acrylamide Gel*

Acrylamide gels are useful for separating macromolecules of sizes smaller than are easily resolved in agarose gels; this includes most proteins and small bands of DNA (less than or equal to 500kb in length). A 6.0% acrylamide gel electrophoresis was done to isolate single stranded pieces of plasmid DNA. In a 500mL sterile flask, 4.5mL of 40% Acrylamide, 3mL of 5X TBE, and 22.5mL of distilled water was placed. Next, a vertical gel box was obtained. Using a Pasteur pipette, hot .8% agarose was poured around the sides of the vertical gel box tray to form a seal. When the Acrylamide solution was ready to be poured, 300uL of Ammonium Persulfate and 20uL of Temed were added to the flask. The mixture was poured into the vertical gel tray and the comb was added. The gel set in a half hour. The DNA was denatured at 95°C for ten minutes and fast cooled on ice. When the gel was ready, the comb was removed and DNA was loaded into the appropriate wells.

When the gel was finished, it was carefully removed from the gel tray and was placed in a dish with just enough 1/2X TBE to cover it. 25uL of EtBr was added to the 1/2X TBE that covered the gel for staining purposes. The dish was placed on a shaker for twenty minutes in order to stain the DNA. The gel was placed on a UV light box and the fragments were isolated. Since single stranded pieces of DNA aren't as mobile as double stranded pieces of DNA, they won't run as far on a gel. So, it would be expected that single stranded DNA would run higher on the acrylamide gel versus double stranded DNA. Finally, the fragments underwent an electrolution procedure to remove the DNA from the acrylamide gel strips.

### III. *Formation of artificial DNA constructs*

Single and double stranded DNA fragments were annealed to create the branched double stranded and partially single stranded synthetic DNA constructs. Annealing involves heating the two single strands at 90<sup>0</sup>C to denature all base-paired regions and then allowing them to slowly cool to room temperature. This will allow any complementary regions to base pair. The complementary regions base pair because first they are denatured at a very high temperature 90<sup>0</sup>C, and when they are allowed to slowly cool to room temperature the complementary regions will base pair with one another.

### IV. *Analyses of synthetic DNA constructs*

#### *Neutral-Neutral Two-Dimensional Agarose Gels*

The first dimension of the 2-D gel was made with .4% agarose using 1X TBE (.089M Tris-borate, .089 Boric acid, .002M EDTA). In a 500mL sterile flask 1.2g of agarose, 60mL of 5X TBE, and 240mL of distilled water were added. The flask was placed in the microwave and heated on high until the agarose had dissolved. The mixture was cooled to approximately 50<sup>0</sup>C. Once cooled, the gel was ready to be poured onto a gel tray that had a comb inserted. When the gel had set, the comb was removed and the gel tray was placed inside the gel box. Just enough 1X TBE was poured to cover the gel (about 1600mL). The DNA was loaded into the appropriate wells. The first dimension of the 2-D gel was run at 0.7 Volts per centimeter for 24 hours (about 32 Volts).

The lane containing the DNA from the first dimension was cut out, rotated 90<sup>0</sup>, and placed on a large gel tray (6" X 11"). A 1.2% agarose gel solution was made in 350mL of 1X TBE. The solution was microwaved until the agarose dissolved. Using a Pasteur pipette, hot agarose was placed around the strip of agarose containing the DNA from the first dimension in order to seal the strip to the tray. Once the flask of agarose

was cooled, 21  $\mu$ L of EtBr was added and it was poured over the sealed strip from the first dimension. Once set, 1X TBE containing EtBr was poured over the gel (about 1600mL of 1X TBE and 106.6 $\mu$ L of EtBr). The second dimension was run at 5V/cm or 229 Volts total. The voltage was set to 229 Volts for two hours.

### *Southern Blot*

Afterwards, a Southern Blot technique was done in order to transfer the DNA from the gel onto a positively charged nylon membrane. The gel was placed into a glass dish and about 500 mL of Solution 1 (1/4N HCl) was poured over it. The dish was placed on a shaker for 15 minutes. Solution 1 was poured off. 500 mL of Solution 1 was poured over the gel and the dish was again placed on the shaker for 15 minutes. Solution 1 was poured off. 500 mL of Solution 2 (1/2M NaOH, 1M NaCl) was poured over the gel and the dish was placed on the shaker for 15 minutes. Solution 2 was poured off. Again, 500mL of Solution 2 was poured over the gel and it was placed on the shaker for 15 minutes. Solution 2 was poured off. 500 mL of Solution 3 (1/2M Tris, 3M NaCl pH 7.4) was poured over the gel and the dish was placed on the shaker for 30 minutes. Solution 3 was not poured off. Two pieces of blotting paper were cut out to be the same size as the gel. One piece of a positively charged nuclear membrane was cut the size of the gel and my initials were marked at the bottom along with the date in pencil. A blotting sponge was cut out to fit the size of the gel tray and was fully saturated with 10X SSC. One piece of blotting paper was placed on top of the sponge. Next, the gel was inverted and placed on the piece of blotting paper. The membrane was first soaked in water and then in the saved Solution 3 from the last wash. The side of the membrane with the initials and date was placed face down on the gel. The second piece of blotting paper was soaked in the saved Solution 3 and placed on top of the membrane. Around the exposed edges of the sponge (where the gel was not covering) parafilm was placed so the sponge would not

dry out. On top of the blotting paper, about 3 inches of paper towels were stacked very evenly. A weight of some sort was placed (a glass tray) in order to distribute pressure evenly. The gel blotted overnight. The following day, the DNA was crosslinked to the membrane by using the Fisher Biotech Scientific UV Crosslinker Model FB UVXL-100 face up. A radioactive probe was made in order to detect the presence of single stranded DNA.

#### *V. Radioactive Probes/Hybridization*

##### *Probe Modification of NEB Method: Random Primed Synthesis*

First, 50ng of specific DNA fragment was brought to 11uL in water in a sterile eppendorf tube. Next, the DNA was placed on a 90<sup>0</sup>C heat block for five minutes to denature. The DNA was removed quickly and placed on ice so it wouldn't renature. It was spun briefly in the microcentrifuge to pull all moisture in the bottom of the tube. Next, the following reagents from the New England BioLabs Inc. NEBlot Kit were added- 2.5uL of 10X labeling Buffer which includes Random Octadeoxyribonucleotides, 6 uL dNTP mixture (40uM of dCTP,dGTP,dTTP), 2uL of 1:100 dAtp mix (.4uM dATP), 2.5uL of high activity 6000 ci/mmol alpha <sup>32</sup>P dATP(New England Nuclear, BLU-512Z), 1uL DNA polymerase 1-Klenow Fragment. This mixture incubated at room temperature for two hours behind a protective shield.

##### *Spin Column*

The purpose of the spin column is to separate incorporated dATP from unincorporated. A 1mL syringe was obtained. A small amount of siliconized glass wool was placed at the bottom of the syringe. A Pasteur pipette was used to pipette Sephadex G50 hydrated in TE buffer and Sodium Azide as a preservative (10mM Tris pH8.0 and 1mM EDTA) into the syringe. The syringe was filled with Sephadex G50 until the glass

beads reached the top of the syringe. The TE was allowed to drip through the syringe until the syringe contained only packed, hydrated Sephadex G50. The syringe was placed in a 15 mL sterile tube with the cap off. The tube containing the syringe was spun at speed 3 in the clinical centrifuge for five minutes. The tube was removed from the centrifuge and the glass beads were packed down into the syringe. All 25uL of the probe was placed on top of the glass beads. Next, 150 uL of STE (150 mM salt, 10 M Tris, 1 M EDTA at pH 8.0) was placed on top of the probe. The tube containing the syringe was placed in the centrifuge at speed 3 for 5 minutes. Afterwards, the incorporated radioactivity in the eluate was estimated through the use of a Geiger counter. This was compared to the radioactivity remaining in the unincorporated dATP in the matrix of the spin column to see how much of the radiolabelled probe had been incorporated into the probe DNA.

### *Hybridization*

First, a blot was placed into a hybridization tube with just enough prehybe [1% Sarkosyl and 6X Sodium Chloride Phosphate or SCP(.6M  $\text{Na}_2\text{HPO}_4 \cdot 7\text{H}_2\text{O}$ , 2M NaCl, .02M EDTA)] solution to cover the blot. The hybe tube was placed in a Techne Hybridiser HB-1D Hybe Oven at 60°C to warm the blot. The syringe was removed from the tube and was discarded into the radioactive waste container. Next, 12 mL of prehybe solution along with 150uL of sheared salmon sperm was added to the tube and boiled for five minutes. Sheared salmon sperm DNA is nonspecific labelled DNA that will change places with any nonspecific DNA that's on the blot.

The hybe tube was removed from the hybe oven and the prehybe solution was discarded. The probe solution was removed from the boiling water. The contents of the tube containing the radioactive probe were poured into the hybe tube. The hybe tube was placed into the hybe oven at 60°C overnight.

The next day, the hybe tube was removed from the hybe oven. The probe was poured back into its storage tube and stored in the radioactive labeled refrigerator. 2X SCP was poured into the hybe tube to cover the blot and the tube was placed into the hybe oven at 60°C for 30 minutes. Afterwards, the 2X SCP was dumped into the sink. The blot was removed from the hybe tube and placed into a tray. .2X SCP was poured over the blot and the tray was placed on the shaker for 15 minutes. The blot was wrapped in Saran Wrap.

A cassette was obtained along with Fuji Medical X-Ray Film (20.3 X 25.4 cm). These items along with the blot were taken to the dark room. The cassette was opened and the blot was placed face down onto the film. The cassette was locked and placed into a -70°C freezer for varying amounts of time (5 days to two weeks) depending on the radioactivity of the blot and whether a reflective screen was used in order to visualize the location of the DNA.

#### *Computer Analysis*

The computer program Gene Construction Kit version 1.28 was used to make the plasmid maps and for theoretical construct development. Autoradiograms and Polaroid photographs of EtBr stained gels were scanned on a Umax Astra 2000 scanner or a Canon CanoScan FB 620P scanner. The figures which were contrast enhanced required the use of Adobe Photoshop 3.0.5. for illustrative purposes.

## RESULTS

### *I. Isolation of 281 base pair pHS3324 fragment and 686 bp pN28 fragment*

After pHS3324 and pN28 were prepared through a transformation and isolated by a plasmid prep procedure, each plasmid (Figure 6) was cut and the appropriate fragments isolated by using specific restriction enzymes (Figure 7).

First, pHS3324 was cut with Hae II and Hind III and pN28 with Hae II and Bcl I. pHS3324 and pN28 were then loaded onto a 1.2% agarose gel. The voltage was set to 40 Volts for 12 hours. Next, the 281 bp pHS3324 fragment (Figure 8) and the 686 bp pN28 fragment (Figure 8) were cut out of the agarose gel and the DNA was isolated through electrolution.

### *II. Isolation of single stranded plasmid DNA through the use of a 6% acrylamide gel*

The 281 bp pHS3324 fragment was resuspended in 30uL of 1X TE and placed on a heat block at 95<sup>0</sup>C for ten minutes in order to denature. After, it was immediately placed on ice to insure that it wouldn't renature. The denatured 281 bp pHS3324 fragment was loaded onto a 6.0% acrylamide gel. The voltage was set to 100 Volts and the gel ran for 2 1/2 hours.

Three fragments (Figure 9) were isolated and electroluted to obtain the DNA. Initially we thought that the top two bands were single stranded DNA and that the last band was double stranded. The reasoning behind that is due to the fact that single stranded DNA tends to run higher on acrylamide gels than double stranded DNA due to complex structures that can be formed under non-denaturing conditions.





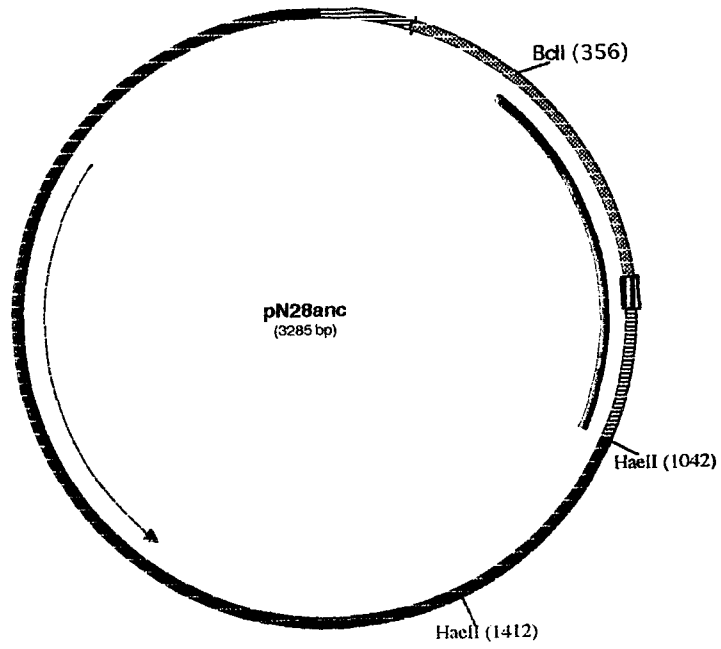
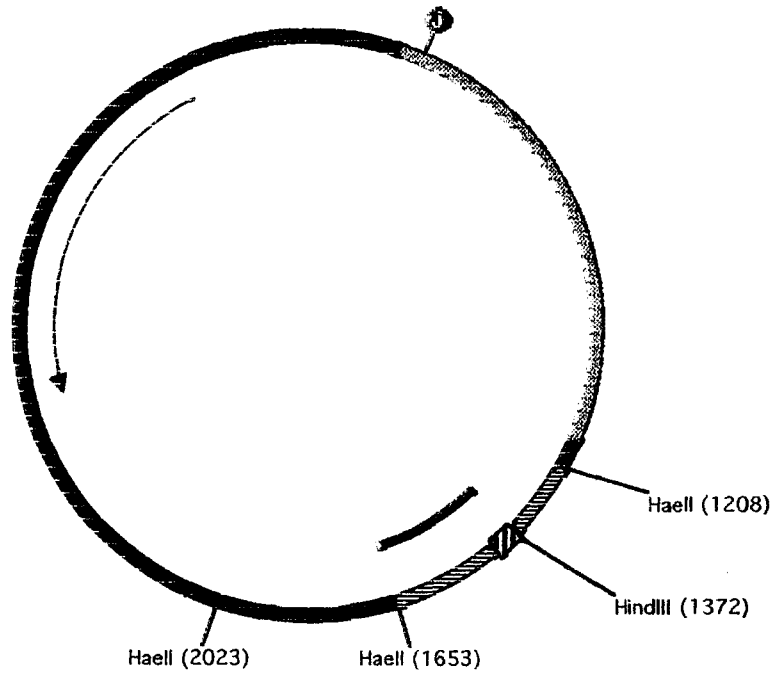



Single Stranded Construct

- Made from pHS3324

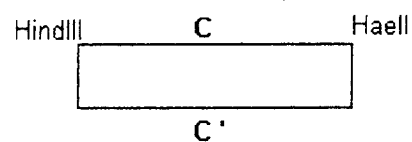

and

- Made from pN28

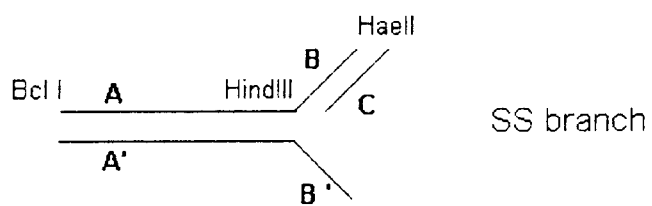
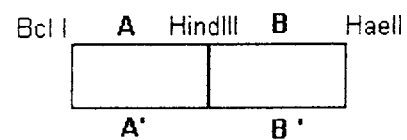



Lambda      pHS3324      pN28

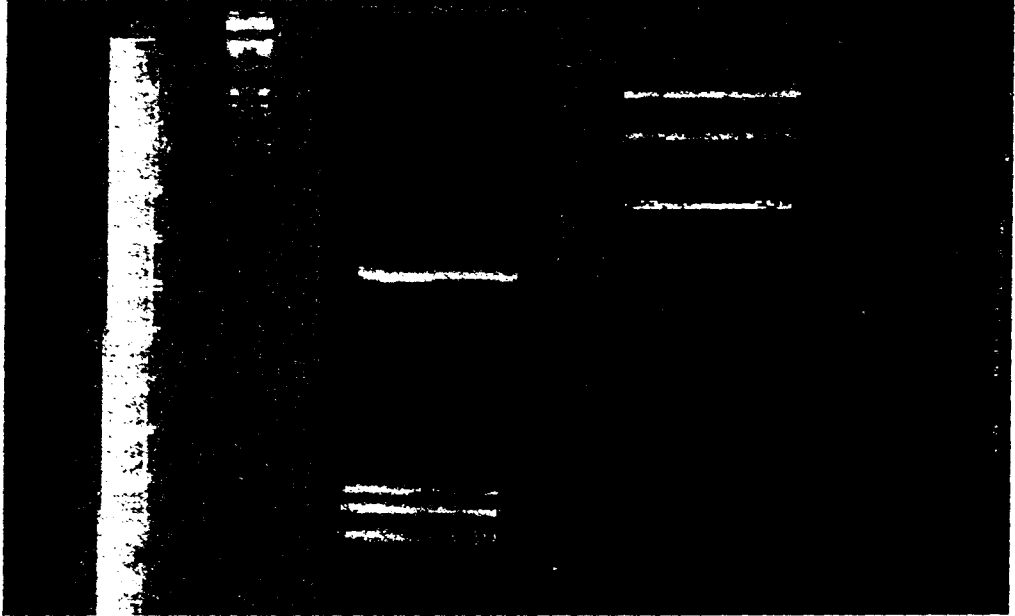



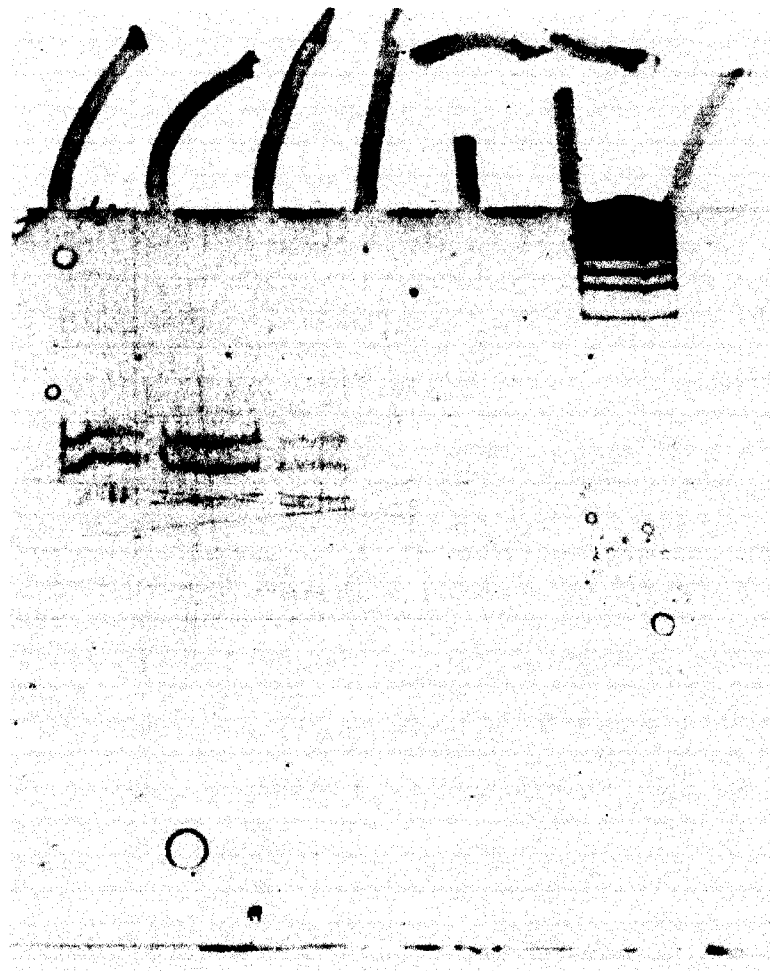

### III. *Assembly of the partially single stranded and double stranded synthetic DNA constructs*

The partially single stranded and double stranded constructs were made by annealing fragments in various combinations. Each of the three fragments isolated from the acrylamide gel (Figure 9) were dissolved in 20uL 1X TE. The 686 bp pN28 fragment was also dissolved in 20uL 1X TE. The following mixtures were made: Mixture 1 contained 2uL from fragment 1 (Figure 9-top single stranded band) from the acrylamide gel, 5uL of the ds pN28 fragment, and 3uL 1X TE. Mixture 2 contained 2uL from fragment 2 (Figure 9-middle single stranded band) from the acrylamide gel, 5uL of the ds pN28 fragment, and 3uL 1X TE. Mixture 3 contained 2uL from fragment 3 (Figure 9-bottom double stranded band) from the acrylamide gel, 5uL of the ds pN28 fragment, and 3uL 1X TE. The three mixtures were vortexed and placed on a 95<sup>0</sup>C heat block for ten minutes to denature. The heat block was then turned off while the tubes remained on it until the temperature reached 32<sup>0</sup>C. This allowed for the DNA in each mixture to slowly anneal which allowed for the construct formation. After, 5uL of yeast total cellular pHS3324 DNA was added to each mixture.

### IV. *Analysis of synthetic partially single stranded and double stranded DNA constructs with yeast total cellular pHS3324 DNA through the use of a Neutral-Neutral Two-Dimensional Agarose Gel*

Mechanisms of DNA replication can be elucidated by analyzing the structure of replicating DNA. One powerful tool for such structural analysis is the two-dimensional agarose gel electrophoresis system. 2-D agarose gel electrophoresis is a technique which is used to determine the approximate location of replication origins and termination sites as well as replication fork directions (Brewer et al. 1988). There are two dimensions of the neutral-neutral two dimensional gel electrophoresis system (Brewer and



Fangman 1991). The first dimension is run at low voltage in a low agarose gel concentration. The reason is to optimize the inverse relationship between the mass of a DNA fragment and its mobility (Brewer and Fangman 1991). The second dimension is run at high voltage in a gel of higher agarose concentration with the direction of electrophoresis  $90^{\circ}$  to the original direction of electrophoresis (Brewer and Fangman 1991). The second dimension also incorporates the use of EtBr. EtBr is an intercalating agent which is capable of inserting itself within the DNA double helix. This makes the molecules more rigid so that more complex molecules may become trapped in the gel matrix. DNA replication proceeds through a number of branched intermediates (Brewer et al. 1988). Due to the branched forms of certain replication intermediates, slower migration is seen in agarose gels when compared to linear unbranched forms of equal mass (Brewer et al. 1988). Under these specific conditions, the contribution of the shape of a molecule to its mobility is exaggerated which causes restriction fragments that contain one or more branches to be reduced in their mobility in the second dimension relative to linear fragments of equal mass (Brewer and Fangman 1991).

Where the constructs appear on a 2-D gel depends on the size and shape of the construct. A normal double stranded linear construct will appear directly on the arc of double stranded linears. A partially single stranded construct of high molecular weight can potentially appear in the range where a double stranded construct would appear (Figure 10). Likewise, a single stranded construct with a low molecular weight will be able to run further in the first dimension and also further in the second dimension because it won't be hindered by the agarose gel (Figure 10).

#### *First Dimension*

The three mixtures were loaded into three separate wells on a .6% agarose gel. The gel was run at .7V/cm (32 Volts) for 24 hours. When the gel was done, the three lanes of DNA (Figure 11) were cut from the gel and rotated  $90^{\circ}$  on the gel tray.



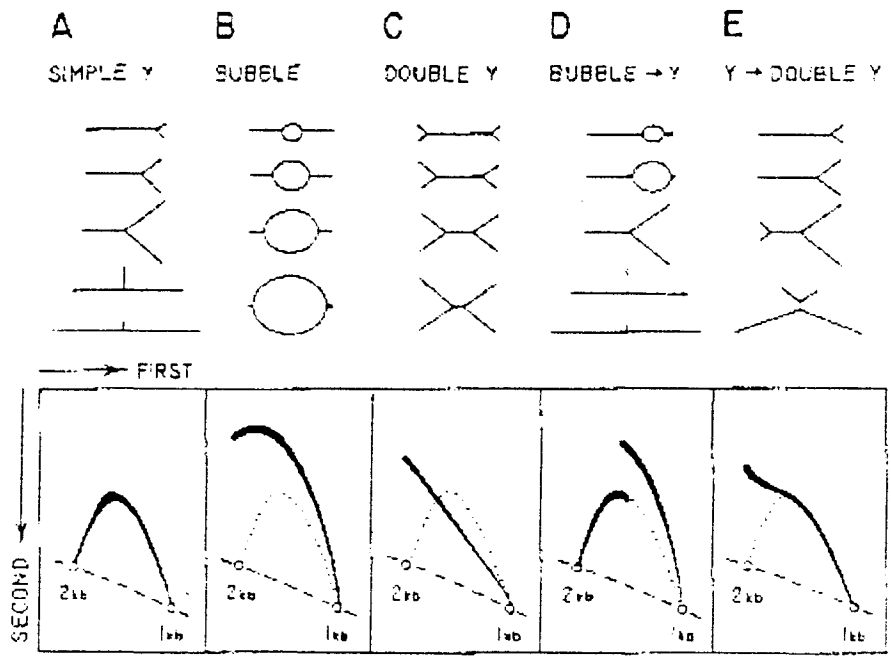



A B C D

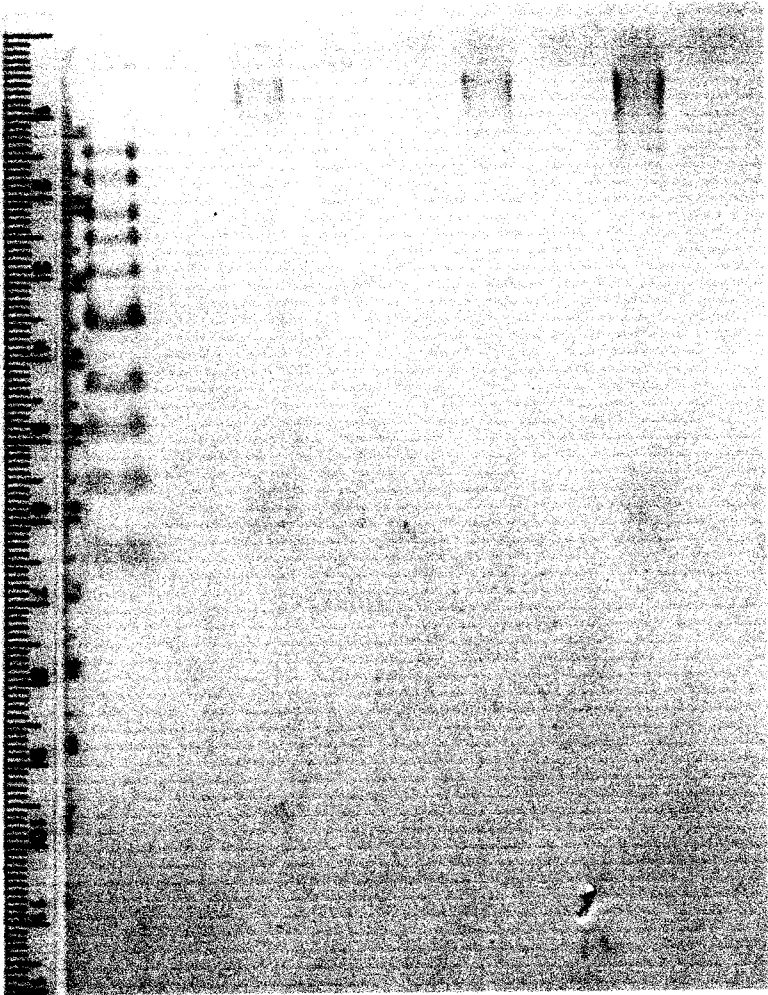

### *Second Dimension*

A 2.0% agarose gel mixture was made which contained ethidium bromide. The agarose gel mixture was poured around the three gel smears. The gel was run at 5V/cm (229 Volts) for two hours at 4°C.

After, a Southern Blot procedure was done and the membrane was probed with a radioactive probe which was made with pHS3324 DNA which contained the 281 bp fragment. The membrane was placed in a cassette with film and the cassette was placed in a freezer at -70°C for one week. The film was then developed which shows the three constructs (Figure 12). Figures 12A and 12B are the partially single stranded constructs. Figure 12C is double stranded pHS3324 (Figure 8 bottom band) mixed with double stranded pN28. The mixture was denatured and allowed to anneal. However, it appears that the two types of DNA never annealed with each other. They were just mixed together and run in the same lane on the 2-D gel. The higher dot in Figure 12C which is directly on the arc of double stranded linears is ds pN28 and the lower dot is ds pHS3324. The arc of double stranded linears appears in Figures 12A, B, and C because 5uL of yeast total cellular DNA from yeast cells containing HS3324 mtDNA was added to each of the three mixtures before the two-dimensional agarose gel was run. This allows for comparison of the constructs to the known double stranded arc of linears.

### *V. Analysis of synthetic partially single stranded and double stranded DNA constructs without yeast total cellular pHS3324 DNA through the use of a Neutral-Neutral Two-Dimensional Agarose Gel*

A second two-dimensional agarose gel was run in order to confirm results. Three mixtures were made: Mixture 1 contained 2uL of the 686 bp ds pN28 fragment and 4uL 1X TE. Mixture 2 contained 5uL from fragment 1 (Figure 9-top single stranded band) and 4uL 1X TE. Mixture 3 contained 2uL from fragment 1 (Figure 9- top ss band),



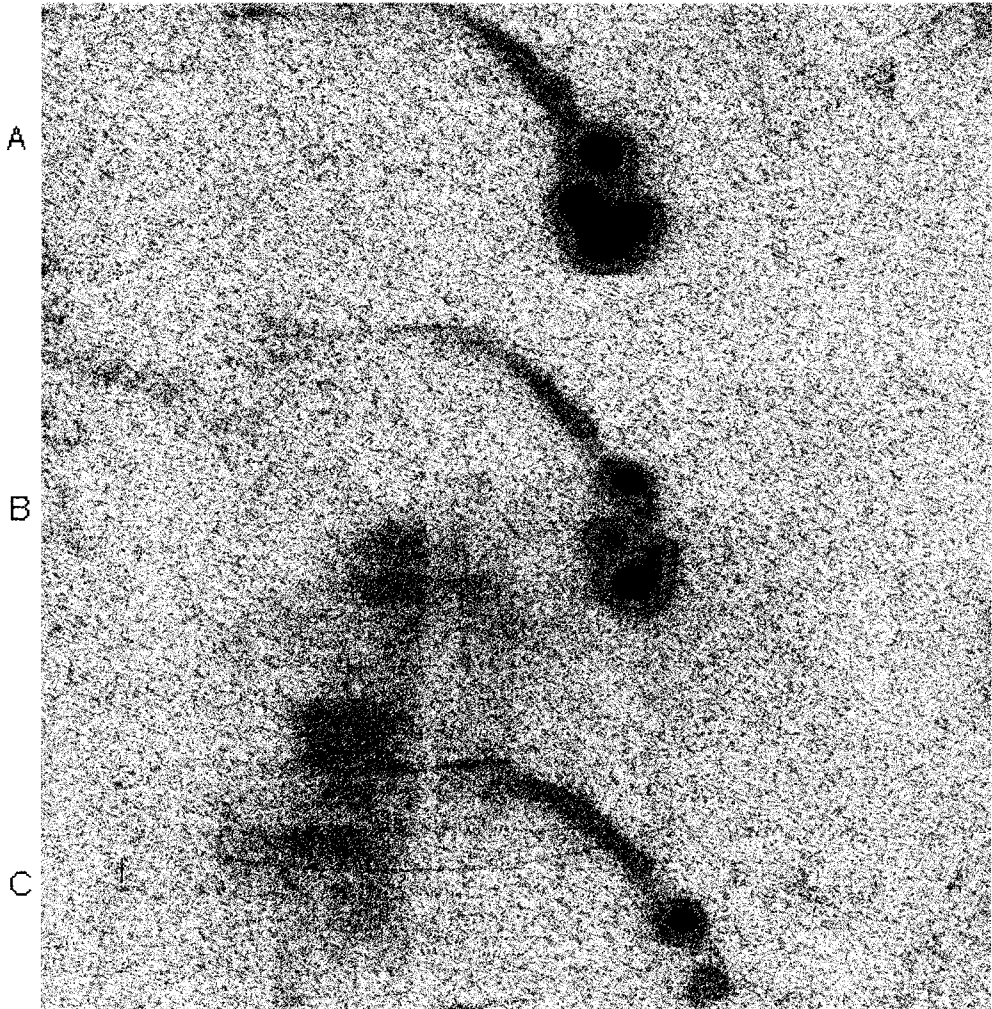



5 $\mu$ L from the 686 bp ds pN28 fragment, and 3 $\mu$ L 1X TE. Mixture 3 underwent an annealing procedure to make the partially single stranded construct. Total yeast cellular HS3324 DNA was not added to the mixtures because I wanted to make sure that the constructs formed in Figure 12 were formed without interference from the extraneous DNA.

#### *First Dimension*

The three mixtures were loaded into three separate wells on a .6% agarose gel. The gel was run at .7V/cm (32 Volts) for 24 hours. When the gel was done, the three lanes of DNA were cut from the gel and rotated 90<sup>0</sup> on the gel tray.

#### *Second Dimension*

A 2.0% agarose gel mixture was made which contained ethidium bromide. The agarose mixture was poured around the three gel smears. The gel was run at 5V/cm (229 Volts) for two hours at 4<sup>0</sup>C.

After, a Southern Blot procedure was done and the membrane was probed with a radioactive probe which was made with pHS3324 DNA which contained the 281 bp fragment. The membrane was placed in a cassette with film and the cassette was placed in a freezer at -70<sup>0</sup>C for one week. The film was then developed which shows the three constructs (Figure 13). Figure 13A is the 686 bp ds pN28 fragment, Figure 13B is the ss pHS3324 fragment 1 from the acrylamide gel, and Figure 13C is the partially ss synthetic construct which is made up of the ds pN28 fragment annealed with the ss pHS3324 fragment.

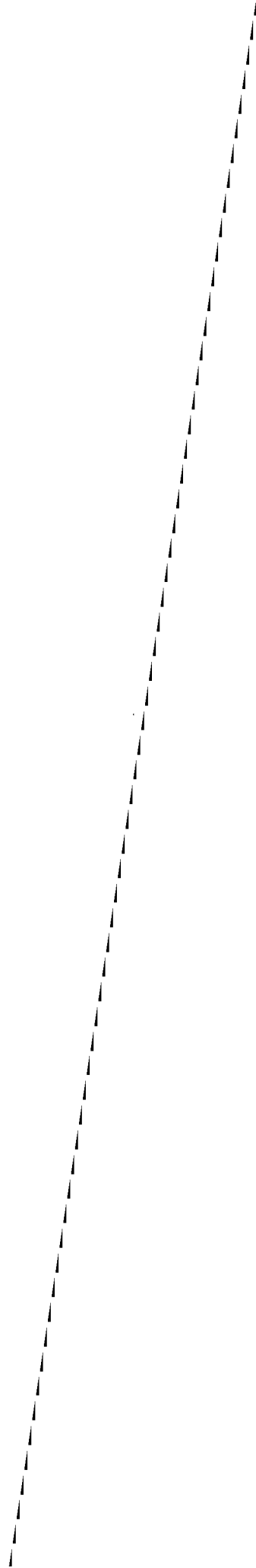

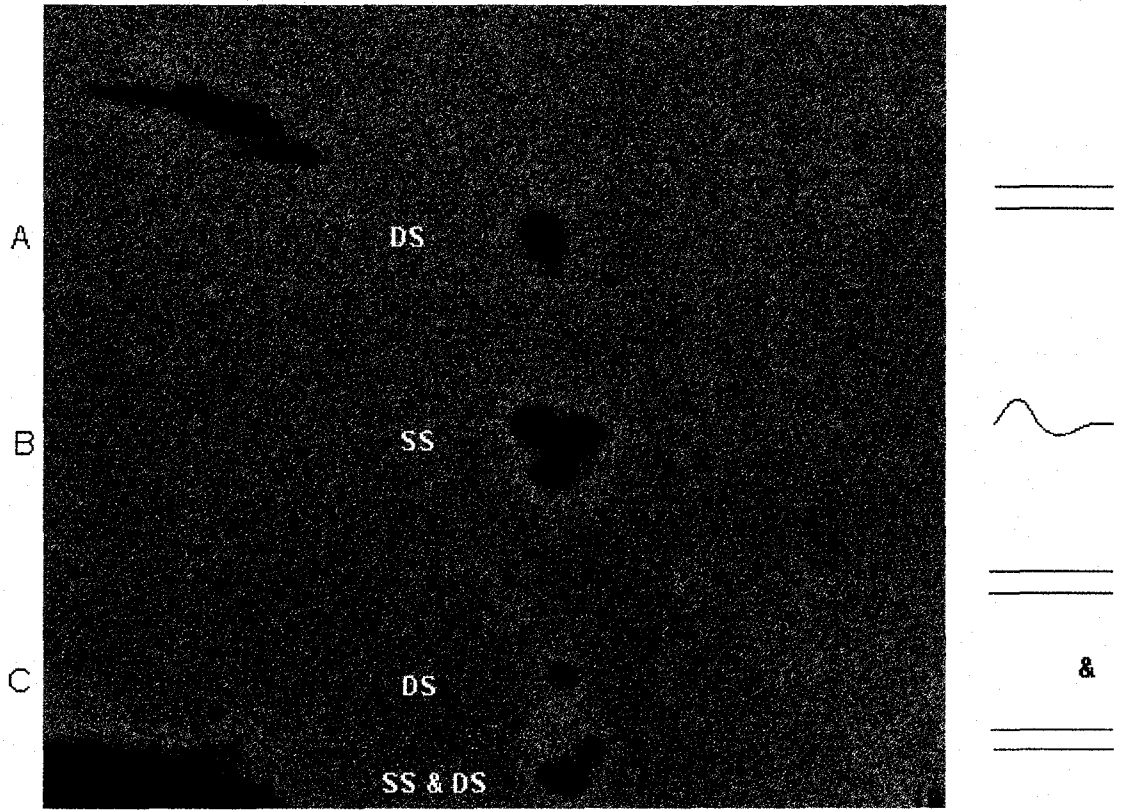

## DISCUSSION

According to the proposed asynchronous and asymmetrical D-loop model of mammalian mitochondrial DNA replication, replication begins from two origins- a heavy (H) strand origin ( $O_H$ ) and a light (L) strand origin ( $O_L$ ) (reviewed in Schmitt and Clayton 1993). Replication begins at  $O_H$  and continues unidirectionally along the parental L-strand to synthesize a full circle of mtDNA (Xu and Clayton 1996). The  $O_L$  begins replication when elongation of the nascent H-strand is about two-thirds complete. At this point, the  $O_L$  is exposed as a single stranded region and presumably forms a secondary structure recognized by a specific primase. The products of this D-loop model are hypothesized to be partially single stranded intermediates (Schmitt and Clayton 1993).

Currently, there is a substantial amount of evidence that supports the D-Loop Model, but little direct analysis of the structure of replicating mtDNA molecules has been done. DNA forms which are known to be partially single stranded (products of the D-loop model) have not been analyzed. So I constructed partially single stranded DNA forms which were analyzed by two-dimensional agarose gel electrophoresis (Figures 12A,12B,13C).

When the partially single-stranded constructs (Figures 12A,12B,13C) are compared with normal double stranded (Figure 14C) and single stranded total cellular mtDNA (Figure 14D), they fall between the double stranded and single stranded arcs. The results for the partially single stranded constructs are typical to fall between the single stranded and double stranded normal total cellular mtDNA arcs because the constructs are neither totally single stranded or double stranded. The double stranded construct (Figure 12C) falls directly on the normal double stranded mtDNA arc (Figure 14C) which is also typical because the construct is fully double stranded.



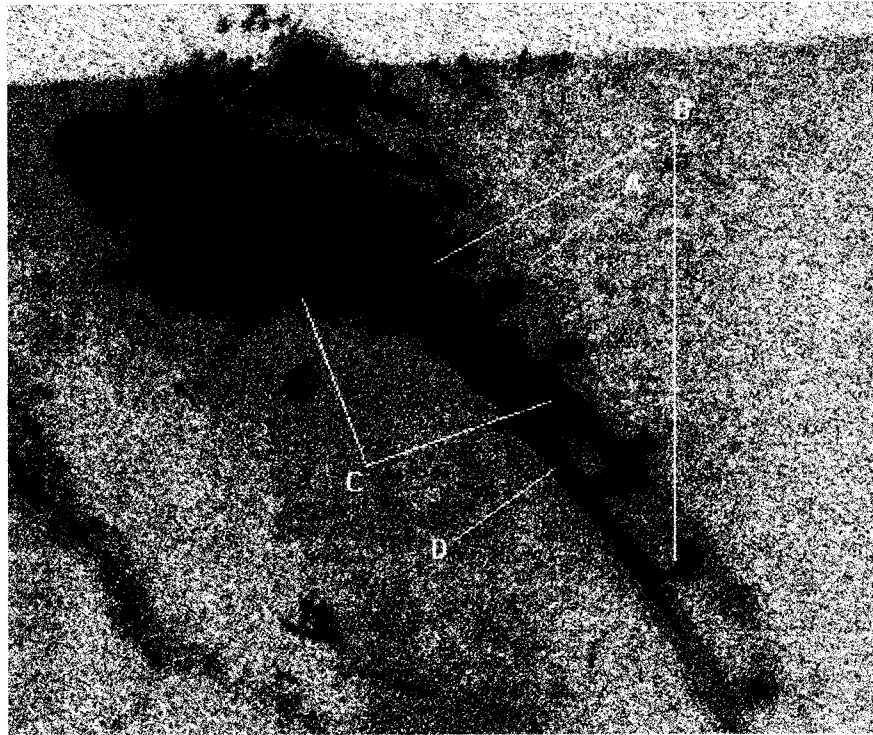

Figures 12A and 12B show how partially single stranded synthetic DNA constructs appear on a two-dimensional agarose gel. Figure 12C shows how double stranded DNA appears on a two-dimensional agarose gel. Figure 12C was the double stranded pHS3324 made from fragment 3(Figure 9 bottom band) from the acrylamide gel annealed with the 686 bp ds pN28 fragment (Figure 8). When the 281 bp pHS3324 fragment was denatured and run on the acrylamide gel, only two single stranded fragments were expected. However, I ended up with three DNA forms on the acrylamide gel (Figure 9). The top two bands were thought to be the single stranded fragments while the bottom band was thought to be double stranded pHS3324 that had reannealed. In Figure 12C it appears that the two types of DNA never annealed to one another- they were just mixed together and run in the same well on the 2-D gel. It appears to be difficult to create partially single stranded forms by simply denaturing and annealing homologous fragments.

Before each of the mixtures in Figure 12 were run on the 2-D gel, total yeast cellular pHS3324 DNA was added to each. In order to confirm my results, a second two-dimensional agarose gel was run (Figure 13) in which no total yeast cellular DNA was added. This was to make sure that the total yeast cellular pHS3324 DNA that was added to each of the mixtures in Figure 12 before they were run on a 2-D gel did not interfere with the construct formation. Figure 13 consisted of the 686 bp ds pN28 fragment alone- Fig. 13A, ss pHS3324 fragment 1 alone-Fig. 13B, and the partially single-stranded construct made from the ds pN28 fragment annealed with the ss pHS3324 fragment 1- Fig. 13C. When the ss pHS3324 fragment 1 from the acrylamide gel is annealed with the ds pN28 fragment (Figure 13C), there is a slight shift to the left versus when the ss pHS3324 fragment 1 is run alone (Figure 13B). The ds pN28 fragment in Figure 13A is almost aligned perfectly with the higher dot in Figure 12C. So, the higher dot directly on

the arc of double stranded linears in Figure 12C is double stranded pN28 and the lower dot is double stranded pHS3324.

Since the products of the D-loop model are hypothesized to be partially single stranded intermediates, the partially single stranded constructs I synthesized (Figures 12A, 12B, and 13C) relate directly to the D-loop model because they allow for visualization of how the hypothesized D-loop products should appear on a two-dimensional agarose gel. The partially single stranded constructs I isolated can be used as reference points for how D-loop intermediates should appear on two-dimensional agarose gels. In the future, other forms expected by the D-loop model which may be synthesized include double stranded Y arc constructs, double stranded D-loop constructs, and other partially single stranded branched structures with one single stranded arm of varying length (Figure 15). When these constructs are eventually made, they too will be able to be used as reference points for how D-loop intermediates should appear on two-dimensional agarose gels. Also, I was unable to check my partially single stranded constructs with single strand nuclease-S1 nuclease to confirm which forms were partially or entirely single stranded. In the future, an experiment could be done in which my partially single stranded constructs are exposed to S1 nuclease and analyzed by two-dimensional agarose gel electrophoresis.

Recently published research finds that upon isolating mammalian mtDNA constructs and examining them on a two-dimensional agarose gel, two classes of mtDNA replication intermediates were detected (Holt et al. 2000). The first class was sensitive to single-strand nuclease-S1 nuclease digestion, which removes single strands, and was presumed to derive from the D-Loop mode of mtDNA replication. These replication intermediates were only present in cells where only maintenance synthesis of mtDNA was expected to be occurring. The second class was not sensitive to single-strand



nuclease digestion and displayed the mobility properties of replication intermediates expected of coupled leading/lagging replication forks found in non-mitochondrial systems. The second class was only present during reamplification of mtDNA after chemically induced depletion. This implies that two mechanisms of mtDNA replication are capable of taking place in mammalian cells.

When the nuclease sensitive mammalian mtDNA intermediates were examined on a two-dimensional agarose gel, they appeared shifted to the left of the arc of double stranded linears (Holt et al. 2000). The partially single stranded constructs I isolated (Figure 12A and 12B) also appeared shifted to the left of the arc of double stranded linears. The mammalian mtDNA double stranded replication intermediates appeared to run higher than the partially single stranded intermediates and were usually on or near the arc of double stranded linears (Holt et al. 2000). The double stranded DNA I examined by a two-dimensional agarose gel (Figure 13A ds pN28) also appeared higher than the partially single stranded constructs (Figure 12A and 12B) and was directly on the arc of double stranded linears. So, my findings appear to correlate with the findings reported by Holt et al. 2000.



Double Stranded Constructs

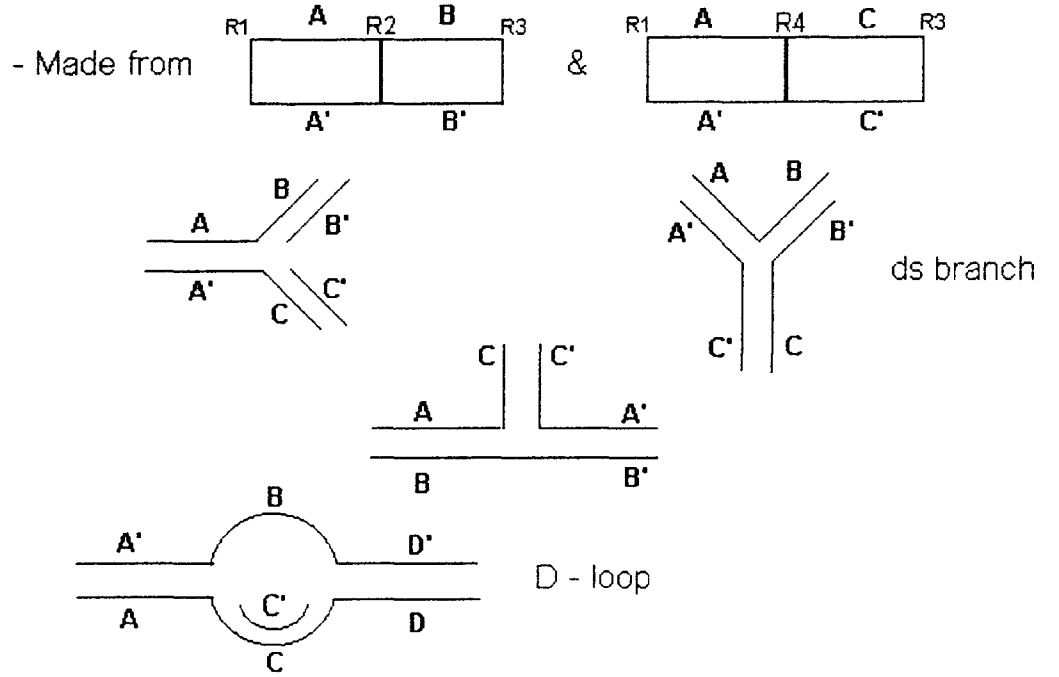

Single Stranded Constructs

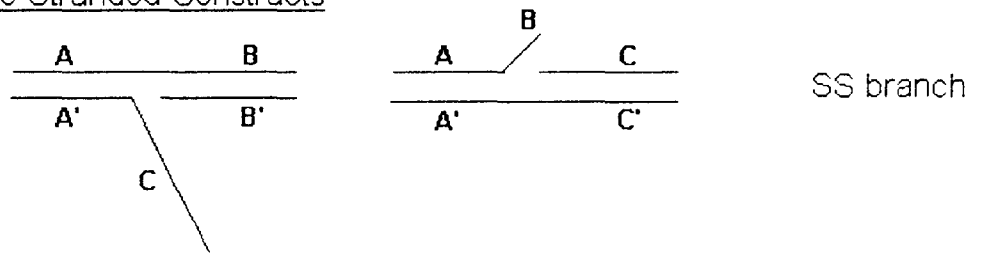

## Works Cited

- Brewer, B.J. et al. Analysis of replication intermediates by two-dimensional agarose gel electrophoresis. New York: Cold Spring Harbor Publications, 1988.
- Brewer, B.J. and W.L. Fangman. 1991. Mapping replication origins in yeast chromosomes. BioEssays13: 317-322.
- Chomyn, A. 1998. The myoclonic epilepsy and ragged-red fiber mutation provides new insights into human mitochondrial function and genetics. American Journal of Human Genetics62: 745-751.
- Clayton, D.A. 1991. Nuclear gadgets in mitochondrial DNA replication and transcription. TIBS16: 107-111.
- Goto, Y-I et al. 1990. A mutation in the tRNA leu (UUR) gene associated with the MELAS subgroup of mitochondrial encephalomyopathies. Nature348: 651-653.
- Griffiths, A.J.F. et al. An Introduction to Genetic Analysis. New York: W.H. Freeman And Company, 1996.
- Han, Z. and C. Stachow. 1994. Analysis of *Schizosaccharomyces pombe* mitochondrial DNA replication by two dimensional gel electrophoresis. Chromosoma103: 162-170.
- Holt, I.J. et al. 1988. Deletions in muscle mitochondrial DNA in patients with mitochondrial myopathies. Nature331: 717-719.
- Holt, I.J. et al. 2000. Coupled leading and lagging strand-synthesis of mammalian mitochondrial DNA. Cell100:515-524.
- Jeong-Yu S. and D.A. Clayton. 1996. Regulation and function of the mitochondrial genome. Journal of Inherited Metabolic Disease19: 443-451.

- Kogoma, T. 1997. Stable DNA replication: interplay between DNA replication, homologous recombination, and transcription. Microbiology and Molecular Biology Reviews1: 212-238.
- Linnane, A.W. et al. 1989. Mitochondrial DNA mutations as an important contributor to aging and degenerative diseases. The Lancet1: 642-645.
- Lorimer, H. E. et al. 1995. A test of the transcription model for biased inheritance of yeast mitochondrial DNA. Molecular and Cellular Biology15: 4803-4809.
- Maniatis, T. et al. Molecular Cloning. New York: Cold Spring Harbor Publications, 1982.
- McShane, M.A. et al. 1991. Pearson Syndrome and mitochondrial encephalomyopathy in a patient with a deletion of mtDNA. American Journal of Human Genetics48: 39-42.
- Nawotka, K.A. and J.A. Huberman. 1988. Two-dimensional gel electrophoretic method for mapping DNA replicons. Molecular and Cellular Biology8: 1408-1413.
- Poulton, J. 1996. New genetics of mitochondrial DNA diseases. British Journal of Hospital Medicine55: 712-716.
- Poulton, J. et al. 1993. Families of mtDNA re-arrangements can be detected in patients with mtDNA deletions: duplications may be a transient intermediate form. Human Molecular Genetics2: 23-30.
- Schmitt, M.E. and D.A. Clayton. 1993. Conserved features of yeast and mammalian mitochondrial DNA replication. Genes and Development 3: 769-774.
- Shoffner, J.M. et al. 1990. Myoclonic epilepsy and ragged-red fiber disease (MERRF) is associated with a mitochondrial DNA tRNA (Lys) mutation. Cell61: 931-937.
- Wallace, D.C. et al. 1988. Familial mitochondrial encephalomyopathy (MERRF): genetic, pathophysiological, and biochemical characterization of a mitochondrial DNA disease. Cell55: 601-610.

- Wong, T.W. and D.A. Clayton. 1985. In vitro replication of human mitochondrial DNA: accurate initiation at the origin of light strand synthesis. Cell42: 951-958.
- Xu, B. and D.A. Clayton. 1996. RNA-DNA hybrid formation at the mitochondrial heavy-strand origin ceases at replication start sites: an implication for RNA-DNA hybrids serving as primers. EMBO Journal15: 3135-3143.
- Yoneda, M. et al. 1992. Marked replicative advantage of human mtDNA carrying a point mutation that causes the MELAS encephalomyopathy. Genetics89: 11164-11168.