

Construction and Analysis of Conformal Mappings  
on Circular and Polygonal Domains

by

Jeffrey A. Osikiewicz

Submitted in Partial Fulfillment of the Requirements  
for the Degree of  
Master of Science  
in the  
Mathematics  
Program

*Dr. Steven R. Went*

Advisor

*8/13/90*

Date

*Sally M. Hitchkins*

Dean of the Graduate School

*August 21, 1990*

Date

YOUNGSTOWN STATE UNIVERSITY

August, 1990

# ABSTRACT

Y-10-4

## Construction and Analysis of Conformal Mappings on Circular and Polygonal Domains

Jeffrey A. Osikiewicz

Master of Science in Mathematics

Youngstown State University, 1990

This paper will consist of an examination of conformal mappings on circular and polygonal domains. In particular, the mapping properties of Möbius, or bilinear, transformations will be investigated. Also, the construction of the Schwarz-Christoffel transformation and its variations will be examined.

## ACKNOWLEDGMENTS

I wish to give my sincerest thanks to Dr. Steven L. Kent for his wisdom and counseling throughout the composition of this paper. His stamina is without equal. I also wish to thank Dr. J. Douglas Faires for both his T<sub>E</sub>Xpertise, and more importantly, his guidance. His advice was always appreciated. Special thanks must also be given to Dr. Eric Wingler for helping me through some rough spots. Finally, I must give thanks to B.E., S.M., and J.D. Without their incessant pestering, I would still be on page one.

## TABLE OF CONTENTS

|  |     |
|--|-----|
| ABSTRACT .....   | ii  |
| ACKNOWLEDGMENTS .....  | iii |
| TABLE OF CONTENTS .....  | iv  |
| INTRODUCTION .....   | v   |
| CHAPTER 0. Review Material .....                                     | 1   |
| CHAPTER 1. Elementary Properties of Conformal Mappings .....         | 3   |
| CHAPTER 2. Elementary Mappings - Möbius Transformations .....        | 14  |
| CHAPTER 3. The Schwarz-Christoffel Transformation .....              | 29  |
| CHAPTER 4. Variations of the Schwarz-Christoffel Transformation .... | 46  |
| CHAPTER 5. Examples .....  | 52  |
| CHAPTER 6. Conclusion .....  | 60  |
| REFERENCES .....   | 61  |



# INTRODUCTION

This paper is an expository report designed to elaborate on topics usually found in a first year graduate course in complex analysis. Namely, those topics concerning conformal mappings and their effect on circular and polygonal domains. Therefore, a graduate student may find this paper useful as a supplement to his studies in complex analysis.

Chapter 0 presents background material referred to in the succeeding chapters of the paper. This chapter is optional for the reader with a working knowledge of complex analysis. Chapter 1 examines the mapping properties of analytic functions. Chapter 2 concerns Möbius, or bilinear, transformations and their effect on circular domains. Chapter 3 is a rigorous development of the Schwarz-Christoffel transformation which maps the upper half-plane onto the interior of a polygon. Chapter 4 then presents some variations of the transformation developed in Chapter 3. Chapter 5 gives some examples of the theory presented in Chapters 2, 3, and 4, while Chapter 6 is the conclusion.

## CHAPTER 0

### Review Material

In this chapter, we present background material which will be used in the subsequent chapters. This chapter is optional for the reader with a working knowledge of complex analysis.

**Definition 0.1 [3].** An arc  $\mathcal{C}$  in the complex plane is a set of points  $z = (x, y)$  such that

$$z(t) = x(t) + iy(t), \quad a \leq t \leq b,$$

where  $x(t)$  and  $y(t)$  are continuous functions of the real parameter  $t$ .

**Definition 0.2 [3].** An arc  $\mathcal{C}$  is a **simple arc**, or *Jordan arc*, if it does not cross itself. That is,  $\mathcal{C}$  is simple if  $z(t_1) \neq z(t_2)$  when  $t_1 \neq t_2$ ,  $t \in [a, b]$ . If  $\mathcal{C}$  is simple except for the fact that  $z(b) = z(a)$ , then  $\mathcal{C}$  is a **simple closed curve**, or a *Jordan curve*.

**Definition 0.3 [3].** An arc  $z = z(t)$  ( $a \leq t \leq b$ ) is a **smooth arc** if its derivative  $z'(t)$  is both continuous and nonzero throughout the entire interval  $a \leq t \leq b$ .

**Definition 0.4 [3].** A set  $D \subseteq \mathbf{C}$  is a **domain** if  $D$  is an open connected set.  $D$  is a **simply connected domain** if every simple closed contour within  $D$  encloses only points of  $D$ . A domain that is not simply connected is said to be **multiply connected**.

We now state, without proof, four theorems and a lemma which will be referred to in subsequent chapters.

**Theorem 0.5 (Riemann Mapping Theorem) [9].** Let  $A$  be a simply connected domain such that  $A \neq \mathbf{C}$ . Then there exists a bijective conformal map  $f : A \rightarrow D$  where  $D = \{z : |z| < 1\}$ . Furthermore, for any fixed  $z_0 \in A$ , we can find an  $f$  such that  $f(z_0) = 0$  and  $f'(z_0) > 0$ . With such a specification,  $f$  is unique.

**Theorem 0.6 (Rouché's Theorem) [14].** If  $f$  and  $g$  are each functions which are analytic inside and on a simply closed contour  $\mathcal{C}$ , and if the strict inequality

$$|f(z) - g(z)| < |f(z)|,$$

holds at each point on  $C$ , then  $f$  and  $g$  must have the same total number of zeros (counting multiplicity) inside  $C$ .

**Theorem 0.7 (Schwarz Reflection Principle) [11].** Let  $A$  be a domain whose boundary includes a linear segment  $L$ , and let  $A'$  be a domain whose boundary includes a linear segment  $L'$ . If the analytic function  $w = f(z)$  maps  $A$  onto  $A'$  in such a way that the segment  $L$  is transformed into the segment  $L'$ , then  $f$  can be continued analytically across  $L$ .

If  $z^*$  is the point symmetric to  $z$  with respect to  $L$ , and  $w^*$  is the point symmetric to  $w = f(z)$  with respect to  $L'$ , this analytic continuation is given by the formula

$$f(z^*) = w^*.$$

**Theorem 0.8 [11].** A function which is analytic on and within a simple closed contour  $C$ , and which takes real values at all points of  $C$ , must reduce to a constant.

**Lemma 0.9 (Schwarz Lemma) [15].** Let  $f$  be analytic on  $A = \{z : |z| < R\}$  and suppose that  $f(0) = 0$  and  $|f(z)| \leq M$  for  $z \in A$ . Then

$$|f'(0)| \leq \frac{M}{R} \quad \text{and} \quad |f(z)| \leq \frac{M|z|}{R}, \quad \text{for } z \in A.$$

If  $|f'(0)| = \frac{M}{R}$ , or if  $|f(z_0)| = \frac{M|z_0|}{R}$  for some  $z_0 \in A$ ,  $z_0 \neq 0$ , then

$$f(z) = e^{i\theta} \frac{Mz}{R}, \quad \theta \in \mathbf{R}.$$

## CHAPTER 1

### Elementary Properties of Conformal Mappings

Consider  $f : \mathbf{C} \rightarrow \mathbf{C}$  defined by  $f(z) = w$ . A graphical representation of  $f$  in the conventional sense is generally not possible because both  $z$  and  $w$  are located in a plane, rather than on a line. It is possible however to visualize the behavior of  $f$  if we display  $z = (x, y)$  and  $w = (u, v)$  as points in two different planes, the  $z$ -plane and the  $w$ -plane, and interpret  $f$  as a mapping or transformation of the points in the  $z$ -plane onto points in the  $w$ -plane. The  $z$ -plane will thus contain the domain of definition of  $f$  and the  $w$ -plane will contain the image of  $f$ .

**Definition 1.1 [9].** A map  $f : D \rightarrow \mathbf{C}$  is called **conformal** at  $z_0 \in D$  if there exists an  $\alpha \in [0, 2\pi)$  and an  $r > 0$  such that for any smooth arc  $z = z(t)$  in  $D$  passing through  $z_0 = z(t_0)$ , the curve  $w(t) = f(z(t))$  is differentiable at  $t_0$ ,  $|w'(t_0)| = r|z'(t_0)|$ , and  $\arg(w'(t_0)) = \arg(z'(t_0)) + \alpha \pmod{2\pi}$ . Here,  $r$  is called the **scale factor** and  $\alpha$  is the **angle of rotation**.

A map will be called **conformal** in a domain  $D$  when it is conformal at every point in  $D$ .

Thus, a conformal map rotates and stretches tangent vectors to curves. It is easily seen that a conformal map preserves angles between intersecting curves. To show this, we first define what is meant by the angle between intersecting curves.

**Definition 1.2 [13].** Let  $C_1$  and  $C_2$  be two simple curves which

- (i) intersect at  $z = z_0$ ,
- (ii) are smooth in a neighborhood of  $z_0$ , and
- (iii) have tangent vectors  $\mathbf{T}_1$  and  $\mathbf{T}_2$  respectively at  $z_0$ .

If  $\theta_1$  and  $\theta_2$  are the local polar angles for  $\mathbf{T}_1$  and  $\mathbf{T}_2$ , respectively, we define  $\Delta\theta_{1,2}|_{z_0}$ , the angle from  $C_1$  to  $C_2$ , as

$$\Delta\theta_{1,2}|_{z_0} = \begin{cases} \theta_2 - \theta_1, & \text{if } \theta_2 - \theta_1 \geq 0 \\ 2\pi + (\theta_2 - \theta_1), & \text{if } \theta_2 - \theta_1 < 0, \end{cases}$$

where  $\theta_1, \theta_2 \in [0, 2\pi)$ .

Thus  $\Delta\theta_{1,2}$  is the positive angle through which  $T_1$  must be rotated in order to locally line up with  $T_2$  (see Figure 1.1). Also note that since  $\theta_1, \theta_2 \in [0, 2\pi)$ , we have  $\Delta\theta_{1,2} \in [0, 2\pi)$ .

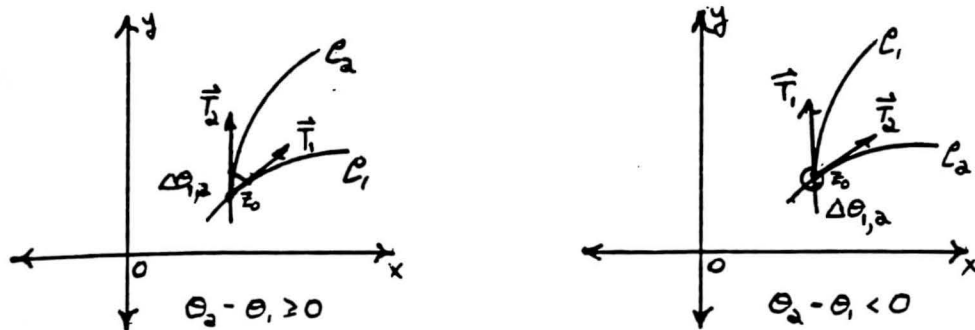

Figure 1.1

Now, to see that a conformal map preserves angles between intersecting curves, let  $f$  be a conformal map in a domain  $D$ , and let  $z_1 = z_1(t)$ ,  $z_2 = z_2(t)$  be two smooth arcs in  $D$  intersecting at  $z_0 = z_1(t_0) = z_2(t_0)$ . Also, let  $\theta_1 = \arg(z_1'(t_0))$ ,  $\theta_2 = \arg(z_2'(t_0))$ . The images of  $z_1$  and  $z_2$  will then be  $w_1(t) = f(z_1(t))$  and  $w_2(t) = f(z_2(t))$ , respectively. Then since  $f$  is conformal at  $z_0$ ,  $\exists \alpha \in [0, 2\pi)$  such that

$$\phi_1 = \arg(w_1'(t_0)) = \theta_1 + \alpha + 2\pi n_1, \quad (1-1)$$

$$\phi_2 = \arg(w_2'(t_0)) = \theta_2 + \alpha + 2\pi n_2, \quad (1-2)$$

where  $n_1, n_2$  are integers. We have

$$\Delta\phi_{1,2} = \Delta\theta_{1,2} + 2\pi k, \quad (1-3)$$

where  $k$  is any integer. But  $\Delta\phi_{1,2}, \Delta\theta_{1,2} \in [0, 2\pi)$ . Hence  $k = 0$  and  $\Delta\phi_{1,2} = \Delta\theta_{1,2}$ .

A mapping that preserves the size of the angle between two smooth arcs but not necessarily the sense is called an **isogonal mapping** [3]. The function  $f(z) = \bar{z}$  is an example of an isogonal mapping. If  $f$  is a nonconstant function analytic at  $z_0$  and  $f'(z_0) = 0$ , then  $z_0$  is called a **critical point** of the transformation  $w = f(z)$ . The next theorem illustrates the mapping behavior of an analytic function near a critical point.

**Theorem 1.3** [3, p.224, exercise 10]. Suppose that a function  $f$  is analytic at  $z_0$  and that

$$f'(z_0) = f''(z_0) = \cdots = f^{(m-1)}(z_0) = 0, \quad f^{(m)}(z_0) \neq 0,$$

for some positive integer  $m \geq 2$ . Then the angle between two smooth arcs which meet at  $z_0$  is magnified  $m$  times by the mapping  $f(z) = w$ .

PROOF: Since  $f$  is analytic at  $z_0$ , it is analytic in some neighborhood of  $z_0$ , and  $f$  has a Taylor series expansion about  $z_0$ . That is,

$$f(z) = f(z_0) + \sum_{n=1}^{\infty} a_n(z - z_0)^n, \quad |z - z_0| < R, \quad a_n = \frac{f^{(n)}(z_0)}{n!}.$$

Hence,

$$\begin{aligned} f(z) - f(z_0) &= \sum_{n=m}^{\infty} a_n(z - z_0)^n \\ &= (z - z_0)^m \sum_{n=0}^{\infty} a_{n+m}(z - z_0)^n \\ &= (z - z_0)^m \left[ a_m + \sum_{n=1}^{\infty} a_{n+m}(z - z_0)^n \right] \\ &= a_m(z - z_0)^m \left[ 1 + \frac{1}{a_m} \sum_{n=1}^{\infty} a_{n+m}(z - z_0)^n \right]. \end{aligned} \quad (1-4)$$

Now, let

$$g(z) = \frac{1}{a_m} \sum_{n=1}^{\infty} a_{n+m}(z - z_0)^n. \quad (1-5)$$

Then  $g$  is analytic for  $|z - z_0| < R$  and  $g(z_0) = 0$ . Thus, (1-4) becomes

$$f(z) - f(z_0) = (z - z_0)^m \left[ \frac{f^{(m)}(z_0)}{m!} \right] [1 + g(z)],$$

$$\begin{aligned} \Rightarrow \arg[f(z) - f(z_0)] &= \arg[(z - z_0)^m] + \arg \left[ \frac{f^{(m)}(z_0)}{m!} \right] + \arg[1 + g(z)] \pmod{2\pi} \\ &= m \arg(z - z_0) + \arg \left[ \frac{f^{(m)}(z_0)}{m!} \right] + \arg[1 + g(z)] \pmod{2\pi}. \end{aligned} \quad (1-6)$$

Now let  $C_1$  be a smooth arc passing through  $z_0$  and let  $\Gamma_1$  be the image of  $C_1$  under the transformation  $w = f(z)$ . Let  $\theta_1$  be the argument of the tangent to the curve  $C_1$  at  $z_0$  and let  $\phi_1$  be the argument of the tangent to the curve  $\Gamma_1$  at  $f(z_0)$ . But,  $\theta_1 = \arg(z - z_0)$  and  $\phi_1 = \arg[f(z) - f(z_0)]$  as  $z \rightarrow z_0$  along  $C_1$ . Thus, as  $z \rightarrow z_0$  along  $C_1$ , (1-6) becomes

$$\phi_1 = m\theta_1 + \arg \left[ \frac{f^{(m)}(z_0)}{m!} \right] + 0, \quad (1-7)$$

since  $g$  is continuous and  $g(z_0) = 0$ . Similarly for a smooth arc  $C_2$  with image  $\Gamma_2$ , we have

$$\phi_2 = m\theta_2 + \arg \left[ \frac{f^{(m)}(z_0)}{m!} \right]. \quad (1-8)$$

From (1-7) and (1-8), we have

$$\Delta\phi_{1,2} = \phi_2 - \phi_1 = m(\theta_2 - \theta_1) = m \Delta\theta_{1,2}.$$

Thus, the angle between two smooth arcs which meet at  $z_0$  is magnified  $m$  times by the mapping  $f(z) = w$ . ■

Theorem 1.3 shows that if  $f$  is conformal at  $z_0$ , then it is necessarily true that  $f'(z_0) \neq 0$ . We will now present two theorems which show that conformality is a characteristic property of analytic functions.

**Theorem 1.4 [9].** *Let  $f : D \rightarrow \mathbf{C}$  be analytic and  $f'(z_0) \neq 0$ . Then  $f$  is conformal at  $z_0$ .*

**PROOF:** Let  $z = z(t)$  be a smooth arc in  $D$  passing through  $z_0 = z(t_0)$ . Then the curve  $w(t) = f(z(t))$  is differentiable at  $t_0$  and by the chain rule,

$$w'(t_0) = f'(z(t_0))z'(t_0) = f'(z_0)z'(t_0).$$

Hence,

$$\arg(w'(t_0)) = \arg(f'(z_0)) + \arg(z'(t_0)) = \alpha + \arg(z'(t_0)),$$

and,

$$|w'(t_0)| = |f'(z_0)| |z'(t_0)| = r |z'(t_0)|.$$

Thus,  $f$  is conformal at  $z_0$ , its angle of rotation being  $\arg(f'(z_0))$ , and its scale factor being  $|f'(z_0)|$ . ■

The above proof shows that the angle of rotation  $\arg(f'(z))$ , and the scale factor  $|f'(z)|$ , of an analytic map vary from point to point. But since  $f'$  is continuous for points  $z$  near  $z_0$ ,  $\arg(f'(z))$  and  $|f'(z)|$  will approximate  $\arg(f'(z_0))$  and  $|f'(z_0)|$  respectively. Thus, in a local sense, images of small neighborhoods of  $z_0$  coincide or "conform" to the original region.

We will now show that a mapping  $f(z) = u(x, y) + iv(x, y)$  which is conformal and has continuous partial derivatives of  $u(x, y)$  and  $v(x, y)$  in a given domain must be analytic.

The following theorem relies on the use of conjugate coordinates, so a brief survey of the subject is in order [11, pp. 17-20, 32].

Consider the complex variables  $z = x + iy$  and  $\bar{z} = x - iy$ . Solving for  $x$  and  $y$  yields

$$x = \frac{1}{2}(z + \bar{z}) \quad \text{and} \quad y = \frac{1}{2i}(z - \bar{z}). \quad (1-9)$$

If  $g(x, y)$  is a complex function which has continuous partial derivatives  $g_x$ ,  $g_y$ , and we apply (1-9) and the formal rules of partial differentiation, we have

$$\frac{\partial g}{\partial z} = \frac{1}{2} \left( \frac{\partial g}{\partial x} - i \frac{\partial g}{\partial y} \right) \quad \text{and} \quad \frac{\partial g}{\partial \bar{z}} = \frac{1}{2} \left( \frac{\partial g}{\partial x} + i \frac{\partial g}{\partial y} \right).$$

It can then be shown that if  $g$  is complex differentiable,  $g'(z) = \frac{\partial g}{\partial z}$  and the Cauchy-Riemann equations are equivalent to  $\frac{\partial g}{\partial \bar{z}} = 0$ . It can also be shown that if  $z(t) = x(t) + iy(t)$ , where  $x(t)$  and  $y(t)$  are differentiable functions of a real parameter  $t$ , then

$$\frac{dg}{dt} = \frac{\partial g}{\partial x} \frac{dx}{dt} + \frac{\partial g}{\partial y} \frac{dy}{dt} = \frac{\partial g}{\partial z} z'(t) + \frac{\partial g}{\partial \bar{z}} \overline{z'(t)}. \quad (1-10)$$

We now state the theorem.

**Theorem 1.5 [11].** *Let  $f(z) = u(x, y) + iv(x, y)$  be conformal in a domain  $D$  and assume  $u_x, u_y, v_x, v_y$  exist and are continuous in  $D$ . Then  $f$  is analytic in  $D$ .*

**PROOF:** Let  $z_0 \in D$ . Let  $z_1(t) = z_0 + e^{i\theta_1}t$ ,  $t \in [0, 1]$ , be a linear segment in  $D$  ( $\theta_1 \in [0, 2\pi)$  fixed). Then,

$$\begin{aligned} \frac{df}{dt}(0) &= f_z(0)z_1'(0) + f_{\bar{z}}(0)\overline{z_1'(0)} \\ &= e^{i\theta_1}f_z(0) + e^{-i\theta_1}f_{\bar{z}}(0) \\ &= e^{i\theta_1} [f_z(0) + e^{-2i\theta_1}f_{\bar{z}}(0)]. \end{aligned} \quad (1-11)$$

Let  $\arg\left[\frac{df}{dt}(0)\right] = \phi_1$ . Then (1-11) becomes

$$\begin{aligned} \arg\left[\frac{df}{dt}(0)\right] &= \arg[e^{i\theta_1}] + \arg[f_z(0) + e^{-2i\theta_1}f_{\bar{z}}(0)] \pmod{2\pi} \\ \Rightarrow \phi_1 &= \theta_1 + \arg[f_z(0) + e^{-2i\theta_1}f_{\bar{z}}(0)] \pmod{2\pi}. \end{aligned} \quad (1-12)$$



Now, let  $z_2(t) = z_0 + e^{i\theta_2}t$ ,  $t \in [0, 1]$ , be a linear segment in  $D$  ( $\theta_2 \in [0, 2\pi)$  fixed,  $\theta_2 \neq \theta_1$ ). By a similar process, we have

$$\phi_2 = \theta_2 + \arg [f_z(0) + e^{-2i\theta_2} f_{\bar{z}}(0)] \pmod{2\pi},$$

where  $\phi_2 = \arg[\frac{df}{dt}(0)]$ . Since  $f$  is given to be conformal at  $z_0$ , it must be true that  $\Delta\phi_{1,2} = \Delta\theta_{1,2}$ . But this implies that  $\arg [f_z(0) + e^{-2i\theta} f_{\bar{z}}(0)]$  is constant for  $\theta \in [0, 2\pi)$ . Now,

$$\beta = f_z(0) + e^{-2i\theta} f_{\bar{z}}(0),$$

describes a circle of center  $f_z(0)$  and radius  $f_{\bar{z}}(0)$  as  $\theta$  varies from 0 to  $\pi$ . Hence  $\arg \beta$  can remain constant only if the radius of the circle is zero. That is,  $f_{\bar{z}}(0) = 0$ . But this condition implies that  $f$  satisfies the Cauchy-Riemann equations. Also, since  $u_x, u_y, v_x, v_y$  were assumed to be continuous,  $f$  will be analytic at  $z_0$ . Since  $z_0$  was chosen arbitrarily in  $D$ ,  $f$  is analytic in  $D$ . ■

Theorems 1.4 and 1.5 show that conformal maps and analytic functions are interrelated. Thus, throughout the remainder of this paper, we shall identify a conformal map with an analytic function having a nonzero derivative [9]. We now state, without proof, the inverse function theorem for analytic functions to show that if an analytic function  $f$  has a nonzero derivative at a point  $z_0$ , then it will have a local inverse about the point  $z_0$ . That is, a conformal map has a local inverse at every point in its domain.

**Theorem 1.6 [9].** *Let  $f : A \rightarrow \mathbb{C}$  be analytic, let  $z_0 \in A$ , and assume that  $f'(z_0) \neq 0$ . Then there exists a neighborhood  $U$  of  $z_0$  and a neighborhood  $V$  of  $f(z_0)$  such that  $f : U \rightarrow V$  is a bijection and its inverse function  $f^{-1}$  is analytic, with derivative given by*

$$\frac{d}{dw} f^{-1}(w) = \frac{1}{f'(z)}, \quad \text{where } w = f(z).$$

The next theorem shows that the inverse of a conformal map is conformal and that the composition of two conformal maps is also a conformal map.

**Theorem 1.7 [9].** (i) *If  $f : A \rightarrow B$  is conformal and bijective, then  $f^{-1} : B \rightarrow A$  is also conformal.*

(ii) *If  $f : A \rightarrow B$  and  $g : B \rightarrow C$  are conformal and bijective, then  $g \circ f : A \rightarrow C$  is conformal and bijective.*

PROOF: (i) Since  $f$  is bijective,  $f^{-1}$  exists. Then, from Theorem 1.6,  $f^{-1}$  is analytic and

$$\forall w \in B, \quad \frac{d}{dw} f^{-1}(w) = \frac{1}{f'(z)} \neq 0,$$

where  $w = f(z)$ . Thus  $f^{-1}$  is conformal.

(ii) Obviously  $g \circ f$  will be bijective and analytic. Now, from the chain rule,

$$\forall z \in A, \quad \frac{d}{dz} (g \circ f)(z) = g'[f(z)]f'(z) \neq 0,$$

since  $f$  and  $g$  are conformal. Thus,  $g \circ f$  is conformal. ■

We now briefly examine some mapping properties of analytic functions, and hence conformal maps.

**Theorem 1.8 [9].** Let  $f$  be analytic and not constant on a domain  $D$  and let  $z_0 \in D$ . Suppose that  $h(z) = f(z) - w_0$  has a zero of order  $k \geq 1$  at  $z_0$ . Then  $\exists \lambda > 0$  such that, for any  $\epsilon \in (0, \lambda]$ ,  $\exists \delta > 0$  such that if  $0 < |w - w_0| < \delta$ , then  $f(z) - w$  has exactly  $k$  distinct roots in the disk  $0 < |z - z_0| < \epsilon$ .

While somewhat formal in nature, the theorem states that if  $f$  takes on the value  $w_0$  at  $z_0$  with multiplicity  $k$ , then for all  $w$  sufficiently near  $w_0$ , the  $k$  roots of  $f(z) = w$  near  $z_0$  are distinct.

PROOF: Since  $f$  is not constant, the zeros of  $h(z) = f(z) - w_0$  are isolated. Thus,  $\exists \eta > 0$  such that for  $0 < |z - z_0| \leq \eta$ ,  $h(z) \neq 0$ . Now,  $\forall \epsilon \in (0, \eta]$ ,  $\exists \delta > 0$  such that  $|h(z)| = |f(z) - w_0| \geq \delta > 0$ , for  $|z - z_0| = \epsilon$ . This is due to the fact that  $h$  is continuous on the compact set  $|z - z_0| = \epsilon$ . Thus, if  $w$  satisfies  $|w - w_0| < \delta$ , then on  $|z - z_0| = \epsilon$ , we have

- (i)  $f(z) - w_0 \neq 0$ ,
- (ii)  $f(z) - w \neq 0$  (since  $f(z) = w$  implies  $|w - w_0| \geq \delta$ ),
- (iii)  $||f(z) - w| - |f(z) - w_0|| = |w - w_0| < \delta \leq |f(z) - w_0|$ .

By Rouché's Theorem,  $f(z) - w$  has the same number of zeros, counting multiplicities, as  $f(z) - w_0$ , inside the circle  $|z - z_0| = \epsilon$ . Thus, in the disk  $|z - z_0| < \epsilon$ ,  $f(z) - w$  has exactly  $k$  roots, counted with their multiplicities.

Now, since  $f$  is not constant,  $f'$  is not identically zero on  $D$ . Hence, the zeros of  $f'$  are isolated and  $\exists \lambda \in (0, \eta]$  such that for  $0 < |z - z_0| < \lambda$ ,  $f(z) - w_0$  and  $f'$  are not zero.

Thus,  $f(z) - w$  will have exactly  $k$  roots for  $w$  sufficiently near  $w_0$ , but these roots will be first order and hence distinct. ■

The above theorem also shows that for a nonconstant analytic function  $f$  in a domain  $D$ , if  $f'(z) \neq 0 \forall z \in D$ , then  $f$  is one-to-one or **univalent** in  $D$ . The next theorem establishes an important property of conformal maps.

**Theorem 1.9 [10].** *The conformal map of a domain is also a domain.*

Before proving this theorem, a few notes are in order. We will allow the conformal image of a domain to have multiple coverings, i.e. the image of  $D$  may overlap itself. This "overlapping" is clearly illustrated by the function  $f(z) = z^2$  on the unit circle. Also, it may be possible that a domain contains points where the derivative of the mapping function is zero. Thus, the mapping ceases to be conformal at these points. However, it is still acceptable to consider "the conformal map of a domain" even if the domain contains critical points of the map. We now prove the theorem.

PROOF: Let  $w = f(z)$  be analytic in a domain  $D$ , let  $z_0 \in D$ , and let  $f(D) = D'$ . Suppose that  $h(z) = f(z) - w_0$  has a zero of order  $k \geq 1$  at  $z_0$ . From Theorem 1.8,  $\exists \lambda > 0$  and  $\exists \delta > 0$  such that if  $0 < |w - w_0| < \delta$ , then  $f(z) - w$  has exactly  $k$  distinct roots in the disk  $0 < |z - z_0| < \lambda$ . That is, there exists a neighborhood of  $w_0$  which is contained in  $f(D) = D'$ . Thus,  $D$  is open.

Since  $f$  is conformal, continuous arcs in  $D$  will be mapped onto continuous arcs in  $D'$ . Hence  $D'$  is connected. We thus conclude that  $f(D) = D'$  is a domain. ■

Note that if  $w = f(z)$  is univalent in  $D$ , then  $f(D) = D'$  will have no multiply covered points. Such a domain that covers no point more than once is called a *schlicht* or simple domain. Also observe that a univalent map preserves the connectivity of a domain. That is, if  $f$  is a univalent map defined on a simply connected domain  $D$ , then  $f(D)$  will also be simply connected.

The next theorem shows that if a function  $f$  is analytic on a simple closed contour  $C$  and its interior  $D$ , then the image of  $C$  under the mapping  $w = f(z)$  is sufficient to determine the image of  $D$ .

**Theorem 1.10 [7].** Let  $C$  be a simple closed contour, and let  $f$  be analytic on  $C$  and its interior  $D$ . On  $C$ , let  $f$  take no value more than once. Then

- (i) the mapping  $w = f(z)$  transforms  $C$  to a simple closed contour  $C'$ ,
- (ii) as  $z$  traverses  $C$  in the positive direction,  $w = f(z)$  traverses  $C'$  in the positive direction, and
- (iii)  $w = f(z)$  is a univalent map of  $D$  onto  $D'$ , the interior of  $C'$ .

**PROOF:** Since  $f$  is analytic, the image of  $C$  is a closed contour  $C'$ . Also,  $C'$  is simple because  $f(z)$  takes no value more than once. Now let  $w_0$  be any point not on  $C'$ . Then, from the argument principle, the number of times  $w_0$  is taken by  $f$  is given by

$$N_{w_0} = \frac{1}{2\pi i} \int_C \frac{f'(z)}{f(z) - w_0} dz, \quad (1-13)$$

for  $f(z) \neq w_0$  at any point on  $C$ .

Now, let  $w = f(z)$ ,  $dw = f'(z) dz$ . Then (1-13) becomes

$$N_{w_0} = \frac{1}{2\pi i} \int_{C'} \frac{dw}{w - w_0}.$$

By the residue theorem,  $N_{w_0} = 0$  if  $w_0$  is exterior to  $C'$ . If  $w_0$  is interior to  $C'$ , that is,  $w_0 \in D'$ , then  $N_{w_0} = \pm 1$  depending on how  $C'$  is traversed. But, since  $N_{w_0}$  is nonnegative,  $N_{w_0} = 1$  for  $w_0 \in D'$ , and  $C'$  is traversed in the positive direction.

Thus, every point in  $D'$  is taken exactly once by a value in  $D$  and values exterior to  $C'$  can not be images of points in  $D$ .

**CLAIM:** No point on  $C'$  can be the image of a point in  $D$ .

**PROOF:** Deny. Then let  $w_0$  be on  $C'$  and suppose  $\exists z_0 \in D$  such that  $f(z_0) = w_0$ . Then, by Theorem 1.8, there exists a neighborhood  $V$  of  $w_0$  such that every point in  $V$  is the image of a point in  $D$ . By the Jordan Curve Theorem, there exists a  $\hat{w}$  in  $V$  such that  $\hat{w}$  is exterior to  $C'$  (see Figure 1.2). Consequently, there exists a  $\hat{z} \in D$  such that  $f(\hat{z}) = \hat{w}$ . But this contradicts the fact that values exterior to  $C'$  can not be images of points in  $D$ . Thus, no point on  $C'$  can be the image of a point in  $D$ .  $\diamond$

Thus,  $f$  is univalent in  $D$  and  $w = f(z)$  maps  $D$  onto  $D'$ .  $\blacksquare$

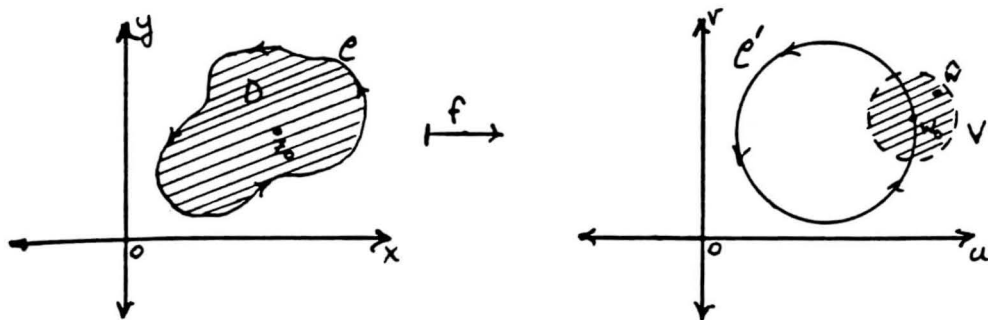

Figure 1.2

We close this chapter by stating, without proof, two theorems which show the importance of conformal mappings as applied to applications of physical problems. There is a rich literature on applications of conformal mappings [3, p.324]. This paper however will not be examining these applications per se, but will rather concentrate on techniques to construct a conformal map from a given region onto a "simpler" one. Once in this "simpler" region, applied problems are more readily solved. An application will be considered in Chapter 5, but this paper will concentrate on the significant techniques in constructing a conformal map from a given region to another.

Recall that a *Dirichlet problem* is a problem that involves finding a harmonic function on a region  $D$  whose values are specified on the boundary of  $D$  and that a *Neumann problem* involves finding a harmonic function on a region  $D$ , where values of the normal derivative of the function are prescribed on the boundary.

**Theorem 1.11 [3].** Suppose that an analytic function

$$w = f(z) = u(x, y) + iv(x, y),$$

maps a domain  $D_z$  in the  $z$  plane onto a domain  $D_w$  in the  $w$  plane. If  $h(u, v)$  is a harmonic function defined on  $D_w$ , i.e.  $h_{uu}(u, v) + h_{vv}(u, v) = 0$ , then the function

$$H(x, y) = h[u(x, y), v(x, y)],$$

is harmonic in  $D_z$ .

Thus, intuitively, a harmonic function remains a harmonic function when transformed from one plane to another by a conformal mapping.

**Theorem 1.12 [3].** Suppose that a transformation

$$w = f(z) = u(x, y) + iv(x, y),$$

is conformal on a smooth arc  $C$ , and let  $\Gamma$  be the image of  $C$  under that transformation. If along  $\Gamma$ , a function  $h(u, v)$  satisfies either of the conditions

$$h = h_0 \quad \text{or} \quad \frac{dh}{dn} = 0,$$

where  $h_0$  is a real constant and  $\frac{dh}{dn}$  denotes the derivative normal to  $\Gamma$ , then along  $C$ , the function

$$H(x, y) = h[u(x, y), v(x, y)],$$

satisfies the corresponding condition

$$H = h_0 \quad \text{or} \quad \frac{dH}{dN} = 0,$$

where  $\frac{dH}{dN}$  denotes derivatives normal to  $C$ .

That is, prescribed conditions on a function or its normal derivative remain unaltered under the change of variables associated with a conformal mapping.

Thus, Theorems 1.11 and 1.12 give a technique for solving Dirichlet or Neumann problems. This involves transforming a given boundary value problem in the  $xy$ -plane into a "simpler" one in the  $uv$ -plane in which the problem is more readily solved. Then using Theorems 1.11 and 1.12, the solution of the original problem can be written in terms of the solution obtained in the  $uv$ -plane.

## CHAPTER 2

### Elementary Mappings - Möbius Transformations

As was stated at the end of Chapter 1, a technique for solving Dirichlet and Neumann problems involves finding a conformal map that will transform a given domain onto a "simpler one." Once in this new domain, the problem may be more readily solved. In this chapter, we shall investigate the properties of an important class of conformal maps called *Möbius* or *bilinear* transformations. These transformations will yield a technique for mapping a disk or half plane onto another disk or half plane.

We first examine the mapping defined by

$$w = f(z) = az + b, \quad a, b \in \mathbf{C}, \quad a \neq 0. \quad (2-1)$$

To study the effect of (2-1), consider the case when  $b = 0$ . Letting  $z = \rho e^{i\theta}$  and  $a = |a|e^{i\phi}$ , (2-1) will yield  $w = \rho|a|e^{i(\theta+\phi)}$ . Thus, under (2-1),  $z$  will be rotated an angle  $\phi$  about the origin and the modulus of  $z$  will be magnified (or contracted) by a factor of  $|a|$ . Hence, the transformation  $z \rightarrow az$ , merely rotates and magnifies (or contracts if  $|a| < 1$ ) all points in the complex plane.

Now, if  $b \neq 0$ , then (2-1) will not only rotate and magnify a given point, but will also translate the point an amount  $\operatorname{Re}(b)$  in the  $x$ -direction and an amount  $\operatorname{Im}(b)$  in the  $y$ -direction. It then follows that under the map  $f(z) = az + b$ , geometric figures will be preserved. That is,  $f(z) = az + b$  will transform circles to circles and lines to lines.

A transformation of the form  $f(z) = az + b$ ,  $a, b \in \mathbf{C}$ ,  $a \neq 0$ , is called a **linear transformation** and it is obviously bijective and conformal in the complex plane.

We now consider a mapping of the form

$$f(z) = \frac{1}{z}. \quad (2-2)$$

Here,  $f$  is called an **inversion** and it is a one-to-one transformation from  $\mathbf{C} \setminus \{0\}$  onto  $\mathbf{C} \setminus \{0\}$ . To see the effect (2-2) has on a nonzero point  $z$ , let  $z = \rho e^{i\theta}$ . Then the image of  $z$  under (2-2) will be  $w = \frac{1}{\rho} e^{-i\theta}$ . Thus, points exterior to the unit circle will be mapped onto

points interior to the unit circle and conversely. Points on the unit circle are invariant. Also, since  $\arg(w) = -\arg(z)$ , (2-2) will reflect points with respect to the real axis. Thus,  $f(z) = \frac{1}{z}$  is an inversion with respect to the unit circle combined with a reflection with respect to the real axis.

Now, since it is true that

$$\lim_{z \rightarrow \infty} \frac{1}{z} = 0 \quad \text{and} \quad \lim_{z \rightarrow 0} \frac{1}{z} = \infty,$$

it is natural to extend  $f(z) = \frac{1}{z}$  to the extended complex plane  $\mathbf{C}_\infty = \mathbf{C} \cup \{\infty\}$  by defining  $f(\infty) = 0$  and  $f(0) = \infty$ . Then  $f(z) = \frac{1}{z}$  will be a bijective map from  $\mathbf{C}_\infty$  to  $\mathbf{C}_\infty$ .

The question now arises as to whether  $f(z) = \frac{1}{z}$  will preserve geometric figures. The answer here is no, but if we regard a line as a circle passing through  $\infty$ , we can state the following:

**Proposition 2.1 [11].** *The mapping  $f(z) = \frac{1}{z}$  transforms circles to circles.*

**PROOF:** A circle in the  $xy$ -plane will be an equation of the form

$$x^2 + y^2 + Ax + By + C = 0, \quad A, B, C, \in \mathbf{R}. \quad (2-3)$$

In polar form, this becomes

$$r^2 + r(A \cos \theta + B \sin \theta) + C = 0, \quad (r, \theta) = (x, y). \quad (2-4)$$

Now, the image of the point  $z = re^{i\theta}$  ( $z \in \mathbf{C} \setminus \{0\}$ ) under the map  $f(z) = \frac{1}{z}$  is

$$w = \rho e^{i\phi} = \frac{1}{r} e^{-i\theta} \quad \implies \quad \rho = \frac{1}{r} \text{ and } \phi = -\theta.$$

Hence, the image of (2-4) is

$$\frac{1}{\rho^2} + \frac{1}{\rho}(A \cos \phi - B \sin \phi) + C = 0. \quad (2-5)$$

If  $C \neq 0$  (corresponding to a circle not passing through the origin), then (2-5) becomes

$$\begin{aligned} 1 + \rho(A \cos \phi - B \sin \phi) + C\rho^2 &= 0 \\ \implies \rho^2 + \rho \left( \frac{A}{C} \cos \phi - \frac{B}{C} \sin \phi \right) + \frac{1}{C} &= 0. \end{aligned}$$



But this is the equation of a circle in the  $w$ -plane not passing through the origin.

If  $C = 0$  (corresponding to a circle through the origin), then (2-5) becomes

$$\begin{aligned} \frac{1}{\rho^2} + \frac{1}{\rho}(A \cos \phi - B \sin \phi) &= 0 \\ \implies A\rho \cos \phi - B\rho \sin \phi + 1 &= 0. \end{aligned} \quad (2-6)$$

If we let  $w = \rho e^{i\phi} = u + iv$ , (2-6) becomes

$$Au - Bv + 1 = 0,$$

which is an equation of a line in the  $w$ -plane. Thus,  $f(z) = \frac{1}{z}$  transforms circles to circles. ■

In a similar fashion, it can be shown that the image of a line through the origin will also be a line through the origin and a line not through the origin is mapped to a circle passing through the origin. We call the family of all lines and circles in  $\mathbf{C}$  **circloids** and note that under stereographic projection, they correspond to circles on the Riemann sphere [4].

**Definition 2.2.** A mapping of the form

$$w = T(z) = \frac{az + b}{cz + d}, \quad a, b, c, d \in \mathbf{C}, \quad ad - bc \neq 0, \quad (2-7)$$

is called a **Möbius or bilinear transformation**.

It will be shown later that the condition  $ad - bc \neq 0$  insures  $T$  will not be a constant. The term Möbius transformation is used because in 1853 A.F. Möbius launched the study of an equivalent class of geometrical transformations which he called *Kreisverwandtschaften* [6].

In a similar fashion to the function  $f(z) = \frac{1}{z}$ , we can define (2-7) on  $\mathbf{C}_\infty$  by setting  $T(\infty) = \infty$  if  $c = 0$ ,  $T(\infty) = \frac{a}{c}$  and  $T(-\frac{d}{c}) = \infty$  if  $c \neq 0$ .

We now claim that (2-7) is conformal on  $\mathbf{C}_\infty$ . To show this, we first define a mapping  $w = f(z)$  to be conformal at  $z = \infty$ , if  $w = f(\frac{1}{z})$  is conformal at  $z = 0$  [2]. Similarly, if  $f(z_0) = \infty$ , then  $f$  is conformal at  $z_0$  if and only if  $f$  has a simple pole at  $z_0$  [10].

We now prove the claim. Obviously,  $T'(z) = \frac{ad-bc}{(cz+d)^2} \neq 0$  for  $z \in \mathbf{C} \setminus \{-\frac{d}{c}\}$ . Now, since  $z_0 = -\frac{d}{c}$  is a simple pole of (2-7),  $T$  is conformal at  $z_0$ . Finally, to show (2-7) is conformal at  $z = \infty$ , we consider  $T(\frac{1}{z})$ :

$$T\left(\frac{1}{z}\right) = \frac{\left[a\left(\frac{1}{z}\right) + b\right]}{\left[c\left(\frac{1}{z}\right) + d\right]} = \frac{(a + bz)}{(c + dz)}.$$

Then,

$$\begin{aligned}T'(\frac{1}{z}) &= \frac{b}{(c+dz)} - \frac{[d(a+bz)]}{(c+dz)^2} \\ &= \frac{[bc+bdz-da-bdz]}{(c+dz)^2} \\ &= \frac{(bc-ad)}{(c+dz)^2},\end{aligned}$$

and when  $z = 0$ ,  $T'(\frac{1}{z}) \neq 0$ . Thus,  $T(z) = \frac{az+b}{cz+d}$  is conformal and hence univalent in  $\mathbf{C}_\infty$ .

Now, if we solve (2-7) for  $z$ , we have

$$\begin{aligned}w = \frac{az+b}{cz+d} &\implies w(cz+d) = az+b \\ &\implies (cw-a)z = -dw+b \\ &\implies z = \frac{-dw+b}{cw-a}.\end{aligned}$$

Hence, the inverse of a Möbius transformation is a Möbius transformation with form

$$T^{-1}(w) = \frac{-dw+b}{cw-a}, \quad (2-8)$$

and we can conclude that a Möbius transformation is a bijection of  $\mathbf{C}_\infty$  onto  $\mathbf{C}_\infty$ .

Now it is easy to see the following:

**Theorem 2.3.** *The set of all Möbius transformations,  $\mathcal{M}$ , forms a group under composition.*

**PROOF:** Obviously, the identity element will be the transformation  $I(z) = z$ . Thus, we need to show closure. That is, let

$$T_1(z) = \frac{a_1z+b_1}{c_1z+d_1} \quad \text{and} \quad T_2(z) = \frac{a_2z+b_2}{c_2z+d_2}, \quad a_1d_1 - b_1c_1 \neq 0, \quad a_2d_2 - b_2c_2 \neq 0.$$

Then,

$$(T_2 \circ T_1)(z) = \frac{a_2 \left( \frac{a_1z+b_1}{c_1z+d_1} \right) + b_2}{c_2 \left( \frac{a_1z+b_1}{c_1z+d_1} \right) + d_2} = \frac{(a_1a_2 + b_2c_1)z + (a_2b_1 + b_2d_1)}{(c_2a_1 + c_1d_2)z + (c_2b_1 + d_1d_2)},$$

and  $T_2 \circ T_1$  is a Möbius transformation.

Now, since  $T^{-1}$  is given by (2-8), and associativity will clearly hold, we may conclude that  $\mathcal{M}$  forms a group under composition. ■

Now observe that if  $c = 0$ , then  $T(z) = \frac{az+b}{cz+d}$  becomes  $T(z) = \left(\frac{a}{d}\right)z + \frac{b}{d}$ , which is a linear transformation. If  $c \neq 0$ , then we can divide the denominator into the numerator to yield

$$\begin{aligned} w &= \frac{a}{c} + \frac{(bc - ad)}{[c(cz + d)]} \\ &= \frac{a}{c} + \left[ \frac{(bc - ad)}{c} \right] \left[ \frac{1}{(cz + d)} \right]. \end{aligned} \quad (2-9)$$

Thus,  $T(z)$  can be written as  $T(z) = (T_3 \circ T_2 \circ T_1)(z)$ , where

$$\begin{aligned} T_1(z) &= cz + d, \\ T_2(z) &= \frac{1}{z}, \\ T_3(z) &= \frac{a}{c} + \left[ \frac{(bc - ad)}{c} \right] z. \end{aligned}$$

$T_1$  and  $T_3$  are linear transformations while  $T_2$  is an inversion. Observe that if  $ad - bc = 0$ , then  $T$  reduces to a constant.

From the results shown earlier, we have proved

**Theorem 2.4.** *Every Möbius transformation maps a circloid onto a circloid.*

Note that circles in the  $z$ -plane passing through  $z = -\frac{d}{c}$ , will be mapped onto straight lines in the  $w$ -plane.

Möbius transformations have the property that, except for the identity transformation, they possess at most two fixed points. That is, there exists at most two points satisfying  $T(z) = z$ . To see this, let  $T(z) = \frac{az+b}{cz+d}$  be a Möbius transformation. Then, all the fixed points of  $T$  must satisfy

$$z = \frac{az + b}{cz + d} \implies cz^2 + (d - a)z - b = 0.$$

This equation has at most two roots unless it is identically zero.

Now let  $T(z) = \frac{az+b}{cz+d}$  be a Möbius transformation, and let  $z_1, z_2, z_3, z_4$  be four distinct points in  $\mathbb{C}$ . Then, if  $w_1, w_2, w_3, w_4$  are the images of  $z_1, z_2, z_3, z_4$  under  $T$ , we have from

(2-9) that for  $i, j = 1, 2, 3, 4, i \neq j$ ,

$$\begin{aligned}
 w_i - w_j &= \left[ \frac{a}{c} + \frac{bc - ad}{c(cz_i + d)} \right] - \left[ \frac{a}{c} + \frac{bc - ad}{c(cz_j + d)} \right] \\
 &= \frac{1}{c} \left[ \frac{bc - ad}{cz_i + d} - \frac{bc - ad}{cz_j + d} \right] \\
 &= \frac{A}{c} \left[ \frac{1}{cz_j + d} - \frac{1}{cz_i + d} \right], \quad \text{where } A = ad - bc \neq 0, \\
 &= \frac{A}{c} \left[ \frac{cz_i + d - cz_j - d}{(cz_j + d)(cz_i + d)} \right] \\
 \Rightarrow w_i - w_j &= \frac{A(z_i - z_j)}{(cz_j + d)(cz_i + d)}. \tag{2-10}
 \end{aligned}$$

Hence,

$$(w_1 - w_4)(w_3 - w_2) = \frac{A^2(z_1 - z_4)(z_3 - z_2)}{\prod_{n=1}^4 (cz_n + d)}, \tag{2-11}$$

and,

$$(w_1 - w_2)(w_3 - w_4) = \frac{A^2(z_1 - z_2)(z_3 - z_4)}{\prod_{n=1}^4 (cz_n + d)}. \tag{2-12}$$

Thus,

$$\frac{(w_1 - w_4)(w_3 - w_2)}{(w_1 - w_2)(w_3 - w_4)} = \frac{(z_1 - z_4)(z_3 - z_2)}{(z_1 - z_2)(z_3 - z_4)}. \tag{2-13}$$

The expression  $\frac{(z_1 - z_4)(z_3 - z_2)}{(z_1 - z_2)(z_3 - z_4)}$ , is called the **cross ratio** of the points  $z_1, z_2, z_3, z_4$ , and is denoted  $C(z_1, z_2, z_3, z_4)$ . Equation (2-13) shows that  $C(w_1, w_2, w_3, w_4) = C(z_1, z_2, z_3, z_4)$ , and hence, the cross ratio is invariant under the Möbius transformation  $T$ . If one of the points  $z_n$  is infinity, then the corresponding cross ratio will be obtained by letting  $z_n \rightarrow \infty$ .

As an example, if  $z_1 = \infty$ , then

$$C(\infty, z_2, z_3, z_4) = \frac{(z_3 - z_2)}{(z_3 - z_4)}.$$

Similar expressions may be obtained for  $w_n = \infty, n = 1, 2, 3, 4$ .

Now, if we replace  $z_4$  by the variable  $z$ , then (2-13) becomes

$$C(z_1, z_2, z_3, z) = C(w_1, w_2, w_3, w), \tag{2-14}$$

where  $w$  is the image of  $z$  under (2-7). It is easily seen that (2-14) is a Möbius transformation and it has the property that it maps the three given points  $z_1, z_2, z_3$  onto  $w_1, w_2, w_3$ . In

fact, (2-14) defines the only Möbius transformation which has this property [4]. To see this, assume  $T_1, T_2 \in \mathcal{M}$ , and that they both map  $z_1, z_2, z_3$  onto  $w_1, w_2, w_3$  respectively. Then  $T_2^{-1} \circ T_1$  has  $z_1, z_2, z_3$  as fixed points. But this implies that  $T_2^{-1} \circ T_1 = I$  and consequently  $T_1 = T_2$ .

Since Möbius transformations map circloids to circloids and a circloid is determined by three of its points, (2-14) allows us to find a mapping which carries a given circloid in the  $z$ -plane onto a given circloid in the  $w$ -plane.

We are now in a position to expand on Theorem 2.4. Namely,

**Theorem 2.5 [15].** *If  $C_z$  and  $C_w$  are two circloids, and  $z_1$  and  $z_2$  are two points not lying on  $C_z$  and  $C_w$ , respectively, then there exists a Möbius transformation which maps  $C_z$  onto  $C_w$ , and  $z_1$  onto  $z_2$ .*

**PROOF:** Since a given circloid can be mapped onto the real axis by a particular Möbius transformation, we need only to consider the case when  $C_z$  and  $C_w$  coincide with the real axis.

Let  $z_1$  and  $z_2$  be two points not on the real axis. If  $\text{Im}(z_1) = \text{Im}(z_2)$ , then the translation  $T(z) = z + (z_2 - z_1)$  maps  $C_z$  onto  $C_w$ , and  $T(z_1) = z_2$ .

Now, if  $\text{Im}(z_1) \neq \text{Im}(z_2)$ , then consider the point  $z_0 \in \mathbf{R}$  where the line connecting  $z_1$  and  $z_2$  intersects the real axis. Then the transformation

$$T(z) = z_0 + \left[ \frac{z_2 - z_0}{z_1 - z_0} \right] (z - z_0),$$

maps  $C_z$  onto  $C_w$  and  $T(z_1) = z_2$ . ■

Let  $T$  be a Möbius transformation that maps the circle  $C_z$  onto the circle  $C_w$  and let  $D_z$  denote the interior of  $C_z$ . Then  $D_z$  will map onto the interior or exterior of  $C_w$ . If  $D_z$  does not contain the pole of  $T$ , then it will map onto the interior of  $C_w$  (by Theorem 1.10), and if  $D_z$  contains the pole of  $T$ , then its image will be the exterior of  $C_w$ . If the image of  $C_z$  is a straight line, then the interior and exterior of  $C_z$  will be half-planes bounded by this line.

Another way to determine the image of  $D_z$  under  $T$  is by checking orientation. Observe that by specifying three distinct points  $z_1, z_2, z_3$  on  $C_z$ ,  $C_w$  will acquire a direction determined by traversing  $C_z$  through  $z_1, z_2$ , and  $z_3$  in succession. Consequently,  $C_w$  will also

acquire a direction through the points  $w_1 = T(z_1)$ ,  $w_2 = T(z_2)$ , and  $w_3 = T(z_3)$ . Now as  $C_z$  is traversed through  $z_1, z_2, z_3$ , if  $D_z$  lies to the right, then the image of  $D_z$  will also lie to the right of  $C_w$  (see Figure 2.1). This follows from the fact that  $T$  is conformal.

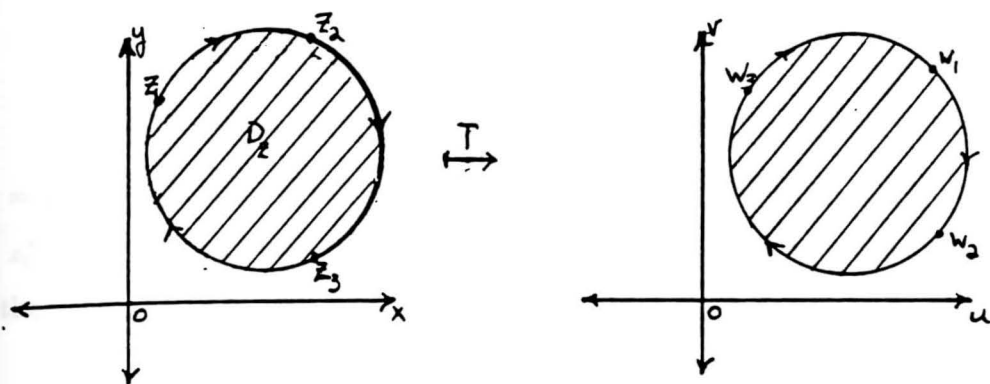

Figure 2.1

Another important property concerning Möbius transformations is their symmetry-preserving property.

**Definition 2.6.** Let  $C$  be a circloid and let  $z_1, z_2$  be two distinct points of  $C$  which have the property that every circloid through  $z_1$  and  $z_2$  meets  $C$  at right angles. Then  $z_1$  and  $z_2$  are said to be symmetric with respect to  $C$ .

Notice that if  $C$  is a line, then  $z_1$  and  $z_2$  are symmetric with respect to  $C$  if and only if  $C$  is the perpendicular bisector of the segment  $\overline{z_1 z_2}$ . The point at infinity is symmetric to itself. Also, if  $C$  is a circle with center  $z_0$ , then  $z_0$  and  $\infty$  are symmetric with respect to  $C$ .

Since a Möbius transformation  $T$  is conformal and preserves circloids, symmetry with respect to  $C$  is preserved by  $T$ . That is, if  $z_1$  and  $z_2$  are symmetric with respect to  $C$ , then  $T(z_1)$  and  $T(z_2)$  are symmetric with respect to  $T(C)$ .

Now, given a circle  $C$  with center  $a$  and radius  $R$ , and given a point  $z_0$ , we wish to derive a formula for finding  $z_0^*$ , the point symmetric to  $z_0$  with respect to  $C$  [14]. First, let us find a Möbius transformation which maps  $C$  onto the real axis. If we let  $z_1 = a - R$ ,

$z_2 = a + Ri$ ,  $z_3 = a + R$ , and  $w_1 = 0$ ,  $w_2 = 1$ ,  $w_3 = \infty$ , (2-14) yields

$$\begin{aligned} \frac{0-w}{0-1} &= \frac{[(a-R)-z][(a+R)-(a+Ri)]}{[(a-R)-(a+Ri)][(a+R)-z]} \\ \Rightarrow w &= \frac{[z-(a-R)][Ri-R]}{[z-(a+R)][Ri+R]} \\ \Rightarrow w &= i \frac{z-(a-R)}{z-(a+R)}. \end{aligned} \quad (2-15)$$

Thus,  $T(z) = i \frac{z-(a-R)}{z-(a+R)}$  maps  $C$  onto the real axis.

If  $z_0$  and  $z_0^*$  are symmetric with respect to  $C$ , then  $T(z_0)$  and  $T(z_0^*)$  are symmetric with respect to the real axis (see Figure 2.2). But this implies that  $T(z_0^*) = \overline{T(z_0)}$ , or from (2-15)

$$i \frac{z_0^* - (a-R)}{z_0^* - (a+R)} = \overline{i \frac{z_0 - (a-R)}{z_0 - (a+R)}} = -i \frac{\bar{z}_0 - (\bar{a} - R)}{\bar{z}_0 - (\bar{a} + R)}.$$

Solving for  $z_0^*$  yields

$$z_0^* = \left[ \frac{R^2}{\bar{z}_0 - \bar{a}} \right] + a. \quad (2-16)$$

Note that (2-16) shows that the point symmetric to  $z_0$  with respect to  $C$  is unique.

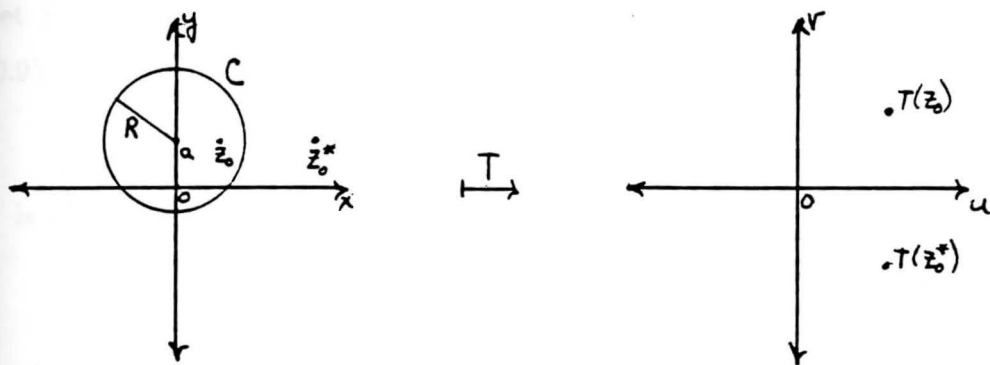

Figure 2.2

We now wish to investigate the problem of finding a univalent function which will map a half-plane or disk onto a half-plane or disk. The following theorems will show that such a function must be a Möbius transformation.

**Definition 2.7 [1].** A univalent mapping of a region onto itself is called an automorphism of that region.

**Lemma 2.8 [1].** Suppose  $f$  is univalent from  $D_1$  onto  $D_2$ .

(a) If  $h$  is univalent from  $D_1$  onto  $D_2$ , then  $h = g \circ f$ , and

(b) if  $h$  is an automorphism of  $D_1$ , then  $h = f^{-1} \circ g \circ f$ ,

where  $g$  is an automorphism of  $D_2$ .

PROOF: (a) Let  $f$  and  $h$  be two univalent functions from  $D_1$  onto  $D_2$ . Then  $g = h \circ f^{-1}$  is an automorphism of  $D_2$ . Thus,  $h = (h \circ f^{-1}) \circ f = g \circ f$ .

(b) Let  $f$  be a univalent function from  $D_1$  onto  $D_2$  and let  $h$  be an automorphism of  $D_1$ . Then,  $g = f \circ h \circ f^{-1}$  is an automorphism of  $D_2$ , and  $h = f^{-1} \circ g \circ f$ . ■

**Theorem 2.9 [15].** If  $f$  is an automorphism of  $D(a; R) = \{z : |z - a| < R\}$ , and  $f(a) = a$ , then  $f$  is a Möbius transformation with the form

$$f(z) = e^{i\theta}(z - a) + a, \quad \theta \in \mathbf{R}. \quad (2-17)$$

Observe that (2-17) is a rotation about the point  $a$ .

PROOF: Since it is possible to find a Möbius transformation  $T$  that will map  $D(a; R)$  to  $D(0; R) = \{z : |z| < R\}$  with  $T(a) = 0$ , we need only consider the case when  $a = 0$ .

Thus, let  $f$  be an automorphism of  $D(0; R)$ , with  $f(0) = 0$ . By the Schwarz Lemma (Lemma 0.9),

$$|f(z)| \leq |z|, \quad \text{for } z \in D(0; R). \quad (2-18)$$

Now,  $f^{-1}$  is also an automorphism of  $D(0; R)$  and  $f^{-1}(0) = 0$ . Again by the Schwarz Lemma,

$$|f^{-1}(z)| \leq |z|, \quad \text{for } z \in D(0; R). \quad (2-19)$$

Combining (2-18) and (2-19) yields

$$|f(z)| \leq |z| = |f^{-1}[f(z)]| \leq |f(z)|, \quad \text{for } z \in D(0; R).$$

Hence,  $|f(z)| = |z|$  for  $z \in D(0; R)$ . From the Schwarz Lemma, we have

$$f(z) = e^{i\theta}z, \quad \theta \in \mathbf{R}.$$

Thus,  $f$  is a Möbius transformation. ■



**Theorem 2.10 [15].** Every univalent mapping of a disk onto a disk is given by a Möbius transformation.

**PROOF:** Let  $f$  be a univalent map which takes  $D(a_1; R_1) = \{z : |z - a_1| < R_1\}$  onto  $D(a_2; R_2) = \{z : |z - a_2| < R_2\}$ , and let  $f(a_1) = b$ . By Theorem 2.5, there exists a Möbius transformation  $T$ , mapping  $D(a_2; R_2)$  onto  $D(a_1; R_1)$  such that  $T(b) = a_1$ . Then  $g = T \circ f$  is an automorphism of  $D(a_1; R_1)$ , with  $g(a_1) = a_1$ . But Theorem 2.9 implies that  $g$  is a Möbius transformation and consequently  $f = T^{-1} \circ g$  is also a Möbius transformation. ■

Using Theorem 2.10, we now wish to classify all univalent mappings of the disk  $D(0; \rho)$  onto the disk  $D(0; r)$ . We have

**Theorem 2.11 [12, exercise 6, p.323].** All univalent mappings of  $D(0; \rho)$  onto  $D(0; r)$  are of the form

$$T(z) = r\rho e^{i\theta} \left( \frac{z - z_0}{\bar{z}_0 z - \rho^2} \right), \quad (2-20)$$

where  $\theta \in \mathbf{R}$  and  $|z_0| < \rho$ .

**PROOF:** By Theorem 2.10, we know the mapping will be a Möbius transformation. Thus, let  $T$  be a Möbius transformation which maps  $D(0; \rho)$  onto  $D(0; r)$ . Then  $T$  will map the circle  $C_\rho : |z| = \rho$  onto the circle  $C_r : |w| = r$ . Now, there exists  $z_0 \in D(0; \rho)$  such that  $T(z_0) = 0$ . According to (2-16), the point

$$z_0^* = \left[ \frac{\rho^2}{\bar{z}_0} - 0 \right] + 0 = \frac{\rho^2}{\bar{z}_0},$$

is symmetric to  $z_0$  with respect to  $C_\rho$ . But, since the origin is the center of  $C_r$ , its symmetric point is  $\infty$ . Hence  $T(z_0^*) = T\left(\frac{\rho^2}{\bar{z}_0}\right) = \infty$ , since Möbius transformations preserve symmetry with respect to a circle. Thus  $T$  has a zero at  $z_0$  and a pole at  $z_0^* = \frac{\rho^2}{\bar{z}_0}$ . That is,  $T$  is of the form

$$T(z) = k \left( \frac{z - z_0}{[z - (\rho^2/\bar{z}_0)]} \right) = k\bar{z}_0 \left( \frac{z - z_0}{\bar{z}_0 z - \rho^2} \right), \quad k \in \mathbf{C}.$$

Now, since  $T(\rho)$  lies on  $C_r$ ,

$$\begin{aligned} r = |T(\rho)| &= \left| k\bar{z}_0 \left( \frac{\rho - z_0}{\bar{z}_0 \rho - \rho^2} \right) \right| \\ &= \left| \frac{k\bar{z}_0}{\rho} \right| \left| \frac{\rho - z_0}{\bar{z}_0 - \rho} \right| \\ &= \left| \frac{k\bar{z}_0}{\rho} \right|, \quad \text{since } \left| \frac{\rho - z_0}{\bar{z}_0 - \rho} \right| = 1. \end{aligned}$$

But this implies that  $|k\bar{z}_0| = r\rho$ , or  $k\bar{z}_0 = r\rho e^{i\theta}$ , where  $\theta \in \mathbf{R}$ . Hence,

$$T(z) = r\rho e^{i\theta} \left( \frac{z - z_0}{\bar{z}_0 z - \rho^2} \right), \quad \theta \in \mathbf{R}, \quad |z_0| < \rho.$$

Conversely, to show that (2-20) maps  $D(0; \rho)$  onto  $D(0; r)$ , we need only show that  $C_\rho$  is mapped onto  $C_r$ . Thus, let  $z = \rho e^{i\theta}$ . Then observe that

$$\begin{aligned} |\bar{z}_0 z - \rho^2| &= |\bar{z}_0 \rho e^{i\theta} - \rho^2| \\ &= \rho |\bar{z}_0 - \rho e^{-i\theta}| \\ &= \rho |\bar{z}_0 - \bar{z}| \\ &= \rho |z - z_0|. \end{aligned}$$

Hence,

$$|T(z)| = r\rho \frac{|z - z_0|}{|\bar{z}_0 z - \rho^2|} = r\rho \left( \frac{1}{\rho} \right) = r,$$

and  $C_\rho$  is mapped onto  $C_r$ . Then, by Theorem 1.10,  $D(0; \rho)$  is mapped onto  $D(0; r)$ . ■

**Corollary 2.12.** *The automorphisms of the unit disk are of the form*

$$T(z) = e^{i\theta} \left( \frac{z - z_0}{\bar{z}_0 z - 1} \right), \quad \theta \in \mathbf{R}, \quad |z_0| < 1.$$

**PROOF:** This follows directly from Theorem 2.11 with  $\rho = r = 1$ . ■

We now consider the problem of finding a univalent function that maps a half-plane onto the unit disk. By performing particular Möbius transformations, namely a rotation and a translation, we need only consider finding a univalent function which maps the upper half-plane  $\text{Im}(z) > 0$  onto the unit disk. From our previous results, it is natural to assume that this function will be a Möbius transformation.

**Theorem 2.13 [1,4].** *All univalent mappings of the upper half-plane  $\text{Im}(z) > 0$  onto the unit disk are Möbius transformations of the form*

$$T(z) = e^{i\theta} \left( \frac{z - z_0}{z - \bar{z}_0} \right), \quad \theta \in \mathbf{R}, \quad \text{Im}(z_0) > 0. \quad (2-21)$$

**PROOF:** We first show that any Möbius transformation mapping the upper half-plane  $\text{Im}(z) > 0$ , onto the unit disk is of the form (2-21). Let  $T$  be such a mapping. Then  $T$

maps the real axis onto the circle  $C : |z| = 1$ . Also, there exists a point  $z_0$  with  $\text{Im}(z_0) > 0$ , such that  $T(z_0) = 0$ . Then  $\bar{z}_0$  is the point symmetric to the real axis and  $T(\bar{z}_0) = \infty$ . Consequently,  $T$  will be of the form

$$T(z) = k \left( \frac{z - z_0}{z - \bar{z}_0} \right), \quad k \in \mathbf{C}.$$

But,

$$1 = |T(0)| = \left| \frac{kz_0}{\bar{z}_0} \right| = |k|.$$

Hence,  $k = e^{i\theta}$ ,  $\theta \in \mathbf{R}$ , and  $T$  has the form

$$T(z) = e^{i\theta} \left( \frac{z - z_0}{z - \bar{z}_0} \right).$$

Now let  $f$  be a univalent mapping of  $\text{Im}(z) > 0$  onto the unit disk with  $f(z_0) = 0$ . By Lemma 2.8,  $f = g \circ T$ , where  $g$  is an automorphism of the unit circle with  $g(0) = 0$ , and  $T$  is a Möbius transformation of the form (2-21). Also,  $f(z_0) = (g \circ T)(z_0) = g(0) = 0$ . Then, by Theorem 2.9,  $g(z) = e^{i\alpha}z$ ,  $\alpha \in \mathbf{R}$ , and

$$f(z) = e^{i(\alpha+\theta)} \left( \frac{z - z_0}{z - \bar{z}_0} \right).$$

That is,  $f$  is a Möbius transformation of the form (2-21). ■

We now wish to find the form of all Möbius transformations which map the real axis onto the real axis [11]. To do this, consider (2-14), the cross ratio formula, with  $z_1, z_2, z_3$ , and  $w_1, w_2, w_3$ , real numbers. Then solving (2-14) for  $w$  yields

$$w = T(z) = \frac{az + b}{cz + d}, \quad a, b, c, d \in \mathbf{R}. \quad (2-22)$$

It is obviously true that (2-22) maps the real line to itself.

Now to determine the image of  $\text{Im}(z) > 0$  under (2-22), we need only consider the image of the point  $z = i$ .

$$\begin{aligned} w = T(i) &= \frac{ai + b}{ci + d} \\ &= \frac{(ai + b)(-ci + d)}{c^2 + d^2} \\ &= \frac{ac + bd}{c^2 + d^2} + i \frac{ad - bc}{c^2 + d^2}. \end{aligned}$$

Then

$$\operatorname{Im}(w) = \frac{ad - bc}{c^2 + d^2}.$$

Thus,  $\operatorname{Im}(z) > 0$  will be mapped to  $\operatorname{Im}(w) > 0$  if  $ad - bc > 0$ , and to  $\operatorname{Im}(w) < 0$  if  $ad - bc < 0$ .

It is only natural now that we have the following theorem.

**Theorem 2.14 [1].** *The automorphisms of the upper half-plane are Möbius transformations of the form*

$$T(z) = \frac{az + b}{cz + d}, \quad a, b, c, d \in \mathbf{R}, \quad ad - bc > 0. \quad (2-23)$$

**PROOF:** From the above discussion, we have seen that (2-23) is an automorphism of  $\operatorname{Im}(z) > 0$ . Thus, let  $f$  be an automorphism of  $\operatorname{Im}(z) > 0$ . Then from Lemma 2.8,  $f$  is of the form  $f = T^{-1} \circ g \circ T$  where

$$T : \operatorname{Im}(z) > 0 \rightarrow D(0; 1) \quad \text{by} \quad T(z) = \frac{z - i}{z + i}, \quad (2-24)$$

and

$$g : D(0; 1) \rightarrow D(0; 1) \quad \text{by} \quad g(z) = e^{i\theta} \left( \frac{z - z_0}{1 - \bar{z}_0 z} \right), \quad \text{for } |z_0| < 1. \quad (2-25)$$

We now show that  $f$  is of the form (2-23). (See [1, exercise 13, p.162.] )

In (2-25), if  $\theta = \pi$ , then

$$\begin{aligned} f(z) &= \left( \frac{z - i}{z + i} \right)^{-1} \circ e^{i\pi} \left( \frac{z - z_0}{1 - \bar{z}_0 z} \right) \circ \left( \frac{z - i}{z + i} \right) \\ &= \left( \frac{z - i}{z + i} \right)^{-1} \circ \left( \frac{z - z_0}{\bar{z}_0 z - 1} \right) \circ \left( \frac{z - i}{z + i} \right). \end{aligned}$$

Now, noting that  $T^{-1}(z) = -i \left( \frac{z+1}{z-1} \right)$ , we have

$$f(z) = \frac{-\operatorname{Im}(z_0)z - (1 + \operatorname{Re}(z_0))}{(1 - \operatorname{Re}(z_0))z + \operatorname{Im}(z_0)} = \frac{\hat{a}z + \hat{b}}{\hat{c}z + \hat{d}},$$

where  $\hat{a}, \hat{b}, \hat{c}, \hat{d} \in \mathbf{R}$ . Observe that

$$\begin{aligned} \hat{a}\hat{d} - \hat{b}\hat{c} &= -(\operatorname{Im}(z_0))^2 + (1 + \operatorname{Re}(z_0))(1 - \operatorname{Re}(z_0)) \\ &= 1 - [(\operatorname{Re}(z_0))^2 + (\operatorname{Im}(z_0))^2] \\ &= 1 - |z_0|^2 > 0, \end{aligned}$$

since  $|z_0| < 1$ . Thus,  $f$  is of the form (2-23).

Now, if in (2-25),  $\theta \neq \pi$ , then let us write  $f = f_1 \circ f_2$  where

$$f_1(z) = T^{-1}(z) \circ e^{i\theta} z \circ T(z),$$

$$f_2(z) = T^{-1}(z) \circ e^{-i\theta} g(z) \circ T(z).$$

Then,  $f_1$  becomes

$$f_1(z) = \frac{-i \left[ e^{i\theta} \left( \frac{z-i}{z+i} \right) \right] - i}{\left[ e^{i\theta} \left( \frac{z-i}{z+i} \right) \right] - 1}. \quad (2-26)$$

Letting  $e^{i\theta} = \cos \theta + i \sin \theta$ , we can write (2-26) as

$$f_1(z) = \frac{(\cos \theta + 1 + i \sin \theta)z - i(\cos \theta - 1 + i \sin \theta)}{i(\cos \theta - 1 + i \sin \theta)z + (\cos \theta + 1 + i \sin \theta)}.$$

Multiplying the numerator and denominator by  $\frac{\cos \theta + 1 - i \sin \theta}{\cos \theta + 1 - i \sin \theta}$ , we have

$$f_1(z) = \frac{(1 + \cos \theta)z + \sin \theta}{-\sin \theta z + (1 + \cos \theta)} = \frac{a_1 z + b_1}{c_1 z + d_1}.$$

Observe that  $a_1, b_1, c_1, d_1 \in \mathbf{R}$  and

$$\begin{aligned} a_1 d_1 - b_1 c_1 &= (1 + \cos \theta)^2 + (\sin \theta)^2 \\ &= 2(1 + \cos \theta) > 0, \quad \text{since } \theta \neq \pi. \end{aligned} \quad (2-27)$$

Now consider the function  $f_2$ . After simplification, it can be written as

$$f_2(z) = \frac{(1 - \operatorname{Re}(z_0))z + \operatorname{Im}(z_0)}{\operatorname{Im}(z_0)z + (1 + \operatorname{Re}(z_0))} = \frac{a_2 z + b_2}{c_2 z + d_2}. \quad (2-28)$$

Observe that  $a_2, b_2, c_2, d_2 \in \mathbf{R}$  and

$$\begin{aligned} a_2 d_2 - b_2 c_2 &= (1 - \operatorname{Re}(z_0))(1 + \operatorname{Re}(z_0)) - (\operatorname{Im}(z_0))^2 \\ &= 1 - \left[ (\operatorname{Re}(z_0))^2 + (\operatorname{Im}(z_0))^2 \right] \\ &= 1 - |z_0|^2 > 0, \end{aligned} \quad (2-29)$$

since  $|z_0| < 1$ . Combining (2-28) and (2-29), we have

$$f(z) = (f_1 \circ f_2)(z) = \frac{\hat{a}z + \hat{b}}{\hat{c}z + \hat{d}},$$

where  $\hat{a}, \hat{b}, \hat{c}, \hat{d} \in \mathbf{R}$  and  $\hat{a}\hat{d} - \hat{b}\hat{c} > 0$ . Thus,  $f$  is of the form (2-23). ■

## CHAPTER 3

### The Schwarz-Christoffel Transformation

The Riemann mapping theorem (Theorem 0.5) guarantees the existence of a univalent function that maps a simply connected domain onto the unit disk. Unfortunately, the theorem does not provide a technique for the actual construction of the function. However, if we consider simply connected domains that have some "regularity", specifically bounded polygons, it is possible to construct the univalent function guaranteed by the Riemann mapping theorem. In this chapter we shall derive an explicit formula for the mapping of the upper half-plane onto the interior of a polygon.

Thus, let  $P$  be a closed polygonal Jordan curve of  $n$  sides lying in the  $w$ -plane, with consecutive vertices at  $A_1, \dots, A_n$ . We assume that the numbering of the vertices gives  $P$  a positive, or counterclockwise, direction. Let  $\pi\alpha_1, \dots, \pi\alpha_n$  denote the interior angles of  $P$  at vertices  $A_1, \dots, A_n$  respectively, and define the exterior angles  $\pi\mu_1, \dots, \pi\mu_n$  of  $P$  by  $\pi\alpha_k + \pi\mu_k = \pi$ ,  $k = 1, \dots, n$  (see Figure 3.1 for the case  $n = 5$ ). Observe that  $0 < \alpha_k < 2$  for  $k = 1, \dots, n$ , and consequently  $-1 < \mu_k < 1$  for  $k = 1, \dots, n$ . Also, since the sum of the exterior angles of a polygon is  $2\pi$ , we have the relation

$$\sum_{k=1}^n \mu_k = 2. \quad (3-1)$$

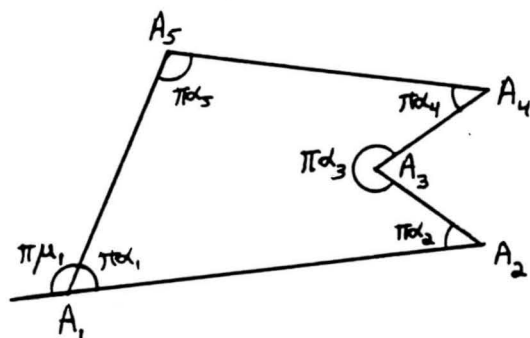

Figure 3.1

Now let  $w = f(z)$  be a univalent function mapping the upper half-plane,  $\Pi_U =$

$\{z : \text{Im}(z) > 0\}$ , onto the interior of  $P$ . We wish to derive the explicit form of  $f$ . We will follow the technique given by Nehari [11]. This will require the use of a consequence of the Schwarz Reflection Principle (Theorem 0.7) which we state, without proof, as a corollary.

**Corollary 3.1 [11].** *Let  $A$  be a domain whose boundary includes a linear segment  $L$ , and let  $A'$  be a domain whose boundary includes a linear segment  $L'$ . If the function  $w = f(z)$  maps  $A$  onto  $A'$  in such a way that the segment  $L$  is transformed into the segment  $L'$ , then  $f$  is analytic at the points of  $L$ .*

Let  $a_1, \dots, a_n$  ( $-\infty < a_1 < \dots < a_n < \infty$ ) be the points on the real axis such that  $f(a_k) = A_k$  for  $k = 1, \dots, n$ . Then the points  $a_1, \dots, a_n$  divide the real axis into  $n$  parts, each of which are mapped to a side of the polygon  $P$ . Here,  $-\infty$  and  $\infty$  are identified by the point at infinity in the extended complex plane. Thus by Corollary 3.1,  $f$  will be analytic on  $\mathbf{R} \setminus \{a_1, \dots, a_n\}$ .

Now, consider the side  $\overline{A_k A_{k+1}}$  of  $P$ . Since  $f(a_k) = A_k$  and  $f(a_{k+1}) = A_{k+1}$ , side  $\overline{A_k A_{k+1}}$  may be represented by the parametric equation

$$w(t) = f(a_k) + t[f(a_{k+1}) - f(a_k)], \quad t \in [0, 1].$$

Consequently, for  $z \in (a_k, a_{k+1})$ ,  $f$  can be written as

$$f(z) = f(a_k) + t(z)[f(a_{k+1}) - f(a_k)], \quad (3-2)$$

where  $t$  is a real differentiable function mapping  $(a_k, a_{k+1})$  onto  $(0, 1)$ . Since  $f$  is differentiable on the interval  $(a_k, a_{k+1})$ , we have

$$f'(z) = t'(z)[f(a_{k+1}) - f(a_k)],$$

$$f''(z) = t''(z)[f(a_{k+1}) - f(a_k)],$$

and,

$$\frac{f''(z)}{f'(z)} = \frac{t''(z)}{t'(z)}.$$

Since  $\frac{t''}{t'}$  is a real function, the function  $g(z) = \frac{f''(z)}{f'(z)}$  will be real for  $z \in \mathbf{R} \setminus \{a_1, \dots, a_n\}$ .

We will now study the behavior of  $g(z) = \frac{f''(z)}{f'(z)}$  at the points  $a_k$ . Let us consider the situation when  $f(a_k) = 0$ . That is, the vertex  $A_k$  of  $P$  lies at the origin in the  $w$ -plane.

Then, for an appropriate  $\epsilon$ ,  $f$  will map the interval  $(a_k - \epsilon, a_k + \epsilon)$  to two line segments,  $C_1$  and  $C_2$ , meeting at  $A_k = 0$  with an angle  $\pi\alpha_k$ .  $C_1$  and  $C_2$  can then be represented by the polar equations

$$C_1: w_1(r) = re^{i\theta} \quad \text{and} \quad C_2: w_2(r) = re^{i(\theta + \pi\alpha_k)}, \quad (3-3)$$

where  $\theta$  is a constant and  $r$  takes positive values (see Figure 3.2).

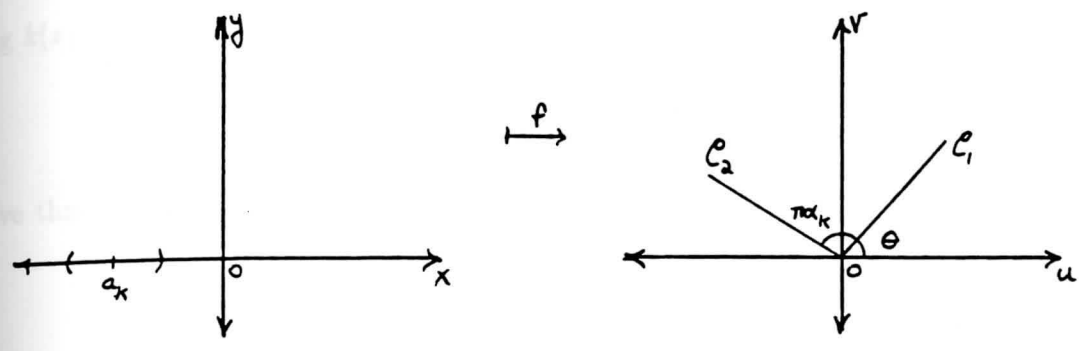

Figure 3.2

Now consider the function  $\phi(w) = w^\beta$ , where  $\beta$  is a real number. Then,

$$\phi[w_1(r)] = r^\beta e^{i\theta\beta} \quad \text{and} \quad \phi[w_2(r)] = r^\beta e^{i(\theta + \pi\alpha_k)\beta}, \quad (3-4)$$

where the branch cut of  $\phi$  is taken so that it does not intersect  $C_1$  or  $C_2$ . Consequently  $\phi$  will map  $C_1$  and  $C_2$  onto a pair of line segments forming an angle  $\pi\alpha_k\beta$ . Letting  $\beta = \alpha_k^{-1}$ , the function

$$H(z) = [f(z)]^{\alpha_k^{-1}}, \quad (3-5)$$

will then map the interval  $(a_k - \epsilon, a_k + \epsilon)$  onto a linear segment passing through the origin. By Corollary 3.1,  $H$  will be analytic at  $a_k$ . Also,  $H'(a_k) \neq 0$ , since the angle  $\pi$  is transformed to the angle  $\pi$ . Now, since  $H(a_k) = 0$  and  $H'(a_k) \neq 0$ ,  $H$  can be written as

$$H(z) = [f(z)]^{\alpha_k^{-1}} = (z - a_k)h(z), \quad (3-5a)$$

where  $h$  is analytic at  $a_k$  and  $h(a_k) \neq 0$ .

If  $f(a_k) \neq 0$ , then (3-5a) will have the form

$$H(z) = [f(z) - f(a_k)]^{\alpha_k^{-1}} = (z - a_k)h(z). \quad (3-6)$$



Hence,

$$f(z) = f(a_k) + (z - a_k)^{\alpha_k} [h(z)]^{\alpha_k},$$

and,

$$\begin{aligned} f'(z) &= \alpha_k (z - a_k)^{\alpha_k - 1} [h(z)]^{\alpha_k} + \alpha_k (z - a_k)^{\alpha_k} [h(z)]^{\alpha_k - 1} h'(z) \\ &= (z - a_k)^{\alpha_k - 1} \left\{ \alpha_k [h(z)]^{\alpha_k} + \alpha_k (z - a_k) [h(z)]^{\alpha_k - 1} h'(z) \right\}. \end{aligned} \quad (3-7)$$

Letting  $k(z) = \alpha_k [h(z)]^{\alpha_k} + \alpha_k (z - a_k) [h(z)]^{\alpha_k - 1} h'(z)$ , (3-7) becomes

$$f'(z) = (z - a_k)^{\alpha_k - 1} k(z). \quad (3-8)$$

Observe that  $k$  is analytic at  $a_k$  and  $k(a_k) \neq 0$ , since  $h(a_k) \neq 0$ . Differentiating (3-8) yields

$$f''(z) = (\alpha_k - 1)(z - a_k)^{\alpha_k - 2} k(z) + (z - a_k)^{\alpha_k - 1} k'(z). \quad (3-9)$$

From (3-8) and (3-9), we have

$$\begin{aligned} g(z) &= \frac{f''(z)}{f'(z)} = \frac{(\alpha_k - 1)(z - a_k)^{\alpha_k - 2} k(z) + (z - a_k)^{\alpha_k - 1} k'(z)}{(z - a_k)^{\alpha_k - 1} k(z)} \\ &= \frac{(\alpha_k - 1)}{z - a_k} + \frac{k'(z)}{k(z)} \\ &= -\frac{\mu_k}{z - a_k} + \frac{k'(z)}{k(z)}, \quad \text{since } \alpha_k + \mu_k = 1. \end{aligned}$$

Since  $k(a_k) \neq 0$ ,  $g$  has a simple pole at  $z = a_k$  with residue  $-\mu_k$ .

Now, since  $k$  is analytic at  $a_k$  and  $k(a_k) \neq 0$ , the function

$$\Phi_k(z) = \frac{f''(z)}{f'(z)} + \frac{\mu_k}{z - a_k},$$

will be analytic at  $a_k$  and consequently the function

$$\Phi(z) = \frac{f''(z)}{f'(z)} + \sum_{k=1}^n \frac{\mu_k}{z - a_k}, \quad (3-10)$$

will be analytic at the points  $a_1, \dots, a_n$ . But  $\frac{f''}{f'}$  was shown to be analytic on  $\mathbf{R} \setminus \{a_1, \dots, a_n\}$ ; consequently  $\Phi$  will be analytic on  $\mathbf{R}$ . Recall that  $\frac{f''}{f'}$  was shown to be real for all points in  $\mathbf{R} \setminus \{a_1, \dots, a_n\}$ , and since  $a_k, \mu_k \in \mathbf{R}$  for  $k = 1, \dots, n$ ,  $\Phi$  will be

real for all points in  $\mathbf{R} \setminus \{a_1, \dots, a_n\}$ . However,  $\Phi$  is analytic, and hence continuous on  $\mathbf{R}$ . Thus,  $\Phi$  will be real for all points in  $\mathbf{R}$ .

We now wish to examine the behavior of  $\Phi$  at  $z = \infty$ . To do this, consider the function  $z = \xi^{-1}$  applied to the segment  $(-\frac{1}{c}, \frac{1}{c})$ , where  $c = \max\{|a_1|, |a_n|\}$ . Under the mapping  $z = \xi^{-1}$ ,  $(-\frac{1}{c}, \frac{1}{c})$  will be transformed to the rays  $(-\infty, -c)$  and  $(c, \infty)$ . Consequently, the function  $f(\xi^{-1})$  will transform the segment  $(-\frac{1}{c}, \frac{1}{c})$  into part of side  $\overline{A_1 A_n}$  of the polygon  $P$ . By Corollary 3.1,  $f(\xi^{-1})$  is analytic at  $\xi = 0$ . Thus  $f(\xi^{-1})$  can be represented by the Taylor series

$$f(\xi^{-1}) = \sum_{n=0}^{\infty} c_n \xi^n = c_0 + c_1 \xi + \dots, \quad |\xi| < R.$$

In terms of  $z$ , this series is

$$f(z) = \sum_{n=0}^{\infty} c_n z^{-n} = c_0 + \frac{c_1}{z} + \dots, \quad |z| > R. \quad (3-11)$$

Differentiating (3-11) yields

$$f'(z) = -\frac{c_1}{z^2} - \frac{2c_2}{z^3} - \dots, \quad (3-12)$$

and,

$$f''(z) = \frac{2c_1}{z^3} + \frac{6c_2}{z^4} + \dots, \quad (3-13)$$

If  $c_m$  is the first non-zero coefficient, then

$$\begin{aligned} \frac{f''(z)}{f'(z)} &= \frac{m(m+1)c_m z^{-(m+2)} + (m+1)(m+2)c_{m+1} z^{-(m+3)} + \dots}{-m c_m z^{-(m+1)} - (m+1)c_{m+1} z^{-(m+2)} - \dots} \\ &= \frac{m(m+1)c_m + (m+1)(m+2)c_{m+1} z^{-1} + \dots}{-m c_m z - (m+1)c_{m+1} - \dots} \\ &= -\frac{1}{z} \left( \frac{m(m+1)c_m + (m+1)(m+2)c_{m+1} z^{-1} + \dots}{m c_m + (m+1)c_{m+1} z^{-1} + \dots} \right). \end{aligned} \quad (3-14)$$

Equation (3-14) shows that  $g(z) = \frac{f''(z)}{f'(z)}$  is analytic at  $z = \infty$  and  $g(\infty) = 0$ . Indeed, with the substitution  $w = \frac{1}{z}$ , (3-14) becomes

$$g(w) = -w \left( \frac{m(m+1)c_m + (m+1)(m+2)c_{m+1}w + \dots}{m c_m + (m+1)c_{m+1}w + \dots} \right),$$

which is analytic and equal to 0 when  $w = 0$ . Consequently,  $\Phi$  will also be analytic at  $z = \infty$  and  $\Phi(\infty) = 0$ . Thus,  $\Phi(z) = \frac{f''(z)}{f'(z)} + \sum_{k=1}^n \frac{\mu_k}{z-a_k}$  is analytic on the extended half-plane  $\bar{\Pi}_U = \{z : \text{Im}(z) \geq 0\}$ , and assumes real values for  $z \in \mathbf{R} \cup \{\infty\}$ . By Theorem 0.8,  $\Phi$  must be a constant. Since  $\Phi(\infty) = 0$ , we have  $\Phi \equiv 0$ . Hence,

$$\begin{aligned} 0 &\equiv \Phi(z) = \frac{f''(z)}{f'(z)} + \sum_{k=1}^n \frac{\mu_k}{z-a_k} \\ \Rightarrow \frac{f''(z)}{f'(z)} &= - \sum_{k=1}^n \frac{\mu_k}{z-a_k}. \end{aligned} \quad (3-15)$$

Integrating (3-15) yields

$$\begin{aligned} \log f'(z) &= - \sum_{k=1}^n \mu_k \log(z-a_k) + \log A, \quad A \in \mathbf{C}, \\ \Rightarrow f'(z) &= A \prod_{k=1}^n (z-a_k)^{-\mu_k}, \\ \Rightarrow f(z) &= A \int_{z_0}^z (t-a_1)^{-\mu_1} \dots (t-a_n)^{-\mu_n} dt + B, \end{aligned}$$

where  $B$  is a complex constant and  $z_0 \in \bar{\Pi}_U$ . We have thus proved

**Theorem 3.2 [8].** Suppose  $w = f(z)$  is a univalent function which maps  $\Pi_U$  onto the interior of a (bounded) closed polygonal Jordan curve  $P$  with interior angles  $\alpha_1\pi, \dots, \alpha_n\pi$  ( $0 < \alpha_k < 2$ ,  $k = 1, \dots, n$ ), and suppose the points  $a_1, \dots, a_n$  ( $-\infty < a_1 < \dots < a_n < +\infty$ ) correspond to the vertices of  $P$ . Then

$$w = f(z) = A \int_{z_0}^z (t-a_1)^{-\mu_1} \dots (t-a_n)^{-\mu_n} dt + B, \quad (3-16)$$

where  $\mu_k = 1 - \alpha_k$ ,  $z_0 \in \bar{\Pi}_U$ , and  $A, B \in \mathbf{C}$ .

It should be noted that three of the points  $a_k$  may be chosen arbitrarily, provided they have the same order as the corresponding vertices. This is due to the fact that the cross ratio formula (2-14) enables one to construct a Möbius transformation that maps three points onto any other three points.

We now wish to prove the converse of Theorem 3.2. Namely, the transformation

$$w = f(z) = A \int_{z_0}^z (z-a_1)^{-\mu_1} \dots (z-a_n)^{-\mu_n} dz + B,$$

maps  $\bar{\Pi}_U \cup \{\infty\}$  one-to-one and continuously onto a set consisting of a closed polygonal Jordan curve  $P$  and its interior. The upper half-plane  $\Pi_U$  is mapped analytically onto the interior of  $P$ .

We begin by examining the function

$$\Psi(z) = (z - a_1)^{-\mu_1} \cdots (z - a_n)^{-\mu_n}, \quad (3-17)$$

where  $a_1, \dots, a_n \in \mathbf{R}$ ,  $-\infty < a_1 < \cdots < a_n < \infty$ ,  $\mu_1, \dots, \mu_n \in \mathbf{R}$ ,  $-1 < \mu_k < 1$ ,  $\sum_{k=1}^n \mu_k = 2$ . Define the branch cut of each factor  $(z - a_k)^{-\mu_k}$  of  $\Psi$  to extend below the real axis. That is, define

$$(z - a_k)^{-\mu_k} = |z - a_k|^{-\mu_k} \exp(-i\mu_k\theta_k) \quad \left(-\frac{\pi}{2} < \theta_k < \frac{3\pi}{2}\right),$$

where  $\theta_k = \arg(z - a_k)$ ,  $k = 1, \dots, n$ . Then  $\Psi$  will be analytic in the domain  $D = \bar{\Pi}_U \setminus \{a_1, \dots, a_n\}$ . Consequently, for  $A, B \in \mathbf{C}$ ,  $z_0 \in D$ , the function

$$f(z) = A \int_{z_0}^z \Psi(t) dt + B, \quad (3-18)$$

will be analytic throughout  $D$ . The path of integration is to be any contour lying within  $D$ . Since  $\Psi(z) \neq 0 \forall z \in D$ , we have

$$f'(z) = A\Psi(z) \neq 0 \quad \forall z \in D. \quad (3-19)$$

**Lemma 3.3 [3].** *The function*

$$f(z) = A \int_{z_0}^z \Psi(t) dt + B,$$

*is analytic in  $\Pi_U$  and continuous in  $\bar{\Pi}_U$ .*

**PROOF:** Since (3-18) is analytic in  $D = \bar{\Pi}_U \setminus \{a_1, \dots, a_n\}$ , it is obviously analytic and continuous in  $\Pi_U$ . Thus we need only examine its behavior near the points  $a_1, \dots, a_n$ . Let us then consider the point  $z = a_1$ . Equation (3-17) can be written as

$$\Psi(z) = (z - a_1)^{-\mu_1} \phi(z), \quad (3-20)$$

where  $\phi(z) = (z - a_2)^{-\mu_1} \cdots (z - a_n)^{-\mu_n}$ . Since  $\phi$  is analytic at  $z = a_1$ , it has a Taylor series expansion about the point  $a_1$ , and (3-20) becomes

$$\begin{aligned}\Psi(z) &= (z - a_1)^{-\mu_1} \left[ \phi(a_1) + \frac{\phi'(a_1)}{1!} (z - a_1) + \cdots \right], \quad |z - a_1| < R_1, \\ &= \phi(a_1)(z - a_1)^{-\mu_1} + (z - a_1)^{1-\mu_1} \sigma(z),\end{aligned}\tag{3-21}$$

where  $\sigma$  is analytic in  $|z - a_1| < R_1$ . If  $\beta(z) = (z - a_1)^{1-\mu_k} \sigma(z)$ , then, since  $1 - \mu_k > 0$ ,  $\beta$  will be a continuous function in the region  $\widehat{D} = \overline{\Pi}_U \cap \{|z - a_1| < R_1\}$ , provided  $\beta(a_1) = 0$ .

Consequently, the function

$$\omega(z) = \int_{z_1}^z \beta(t) dt = \int_{z_1}^z (t - a_1)^{1-\mu_1} \sigma(t) dt,\tag{3-22}$$

will be continuous at  $z = a_1$ , where  $z_1 \in \widehat{D}$  and the path of integration is a contour lying entirely in  $\widehat{D}$ . Also, the function

$$\int_{z_1}^z \phi(a_1)(t - a_1)^{-\mu_1} dt = \frac{\phi(a_1)}{1 - \mu_1} [(z - a_1)^{1-\mu_1} - (z_1 - a_1)^{1-\mu_1}],\tag{3-23}$$

along the same path of integration, is a continuous function of  $z$  at  $a_1$ , if the value of the integral is defined to be the limit of (3-23) as  $z$  approaches  $a_1$  in  $\widehat{D}$ . (Note that this limit will exist since  $1 - \mu_1 > 0$ .) Thus, (3-22) and (3-23) imply that the function

$$\int_{z_1}^z \Psi(t) dt = \int_{z_1}^z \phi(a_1)(t - a_1)^{-\mu_1} dt + \int_{z_1}^z (t - a_1)^{1-\mu_1} \sigma(t) dt,$$

is continuous at  $z = a_1$ , where the path of integration is again a contour lying in  $\widehat{D}$ .

Consequently,

$$f(z) = A \int_{z_0}^z \Psi(t) dt + B = A \left[ \int_{z_0}^{z_1} \Psi(t) dt + \int_{z_1}^z \Psi(t) dt \right] + B,$$

will be continuous at  $z = a_1$ .

The above argument may then be applied to the points  $a_2, \dots, a_n$ . Thus, the function

$$f(z) = A \int_{z_0}^z \Psi(t) dt + B,$$

is continuous in  $\overline{\Pi}_U$ . ■

**Lemma 3.4** [3, exercises 10,11, p.271]. The function

$$f(z) = A \int_{z_0}^z \Psi(t) dt + B,$$

is continuous at  $z = \infty$ .

**PROOF:** We first claim the following:

**CLAIM:** For  $R > 2 \max\{|a_1|, \dots, |a_n|\}$ ,  $\exists M > 0$  such that

$$z \in \bar{\Pi}_U, |z| > R \quad \implies \quad |\Psi(z)| < \frac{M}{|z|^2}. \quad (3-24)$$

**PROOF:** If  $|z| > R > 2 \max\{|a_1|, \dots, |a_n|\}$ , then for  $k = 1, \dots, n$ ,

$$|z - a_k| \leq |z| + |a_k| < |z| + |z| = 2|z|,$$

and

$$|z - a_k| \geq |z| - |a_k| > |z| - \frac{1}{2}|z| = \frac{|z|}{2}.$$

Hence,

$$|z| > R \quad \implies \quad \frac{|z|}{2} < |z - a_k| < 2|z|, \quad k = 1, \dots, n. \quad (3-25)$$

Now,

$$\begin{aligned} |\Psi(z)| &= \left| \prod_{k=1}^n (z - a_k)^{-\mu_k} \right| \\ &= \prod_{k=1}^n \left[ |z|^{-\mu_k} \left| 1 - \frac{a_k}{z} \right|^{-\mu_k} \right] \\ &= |z|^{-2} \prod_{k=1}^n \left| 1 - \frac{a_k}{z} \right|^{-\mu_k}, \quad \text{since } \sum_{k=1}^n \mu_k = 2. \end{aligned}$$

By (3-25), recalling that  $-1 < \mu_k < 1$ , we have  $|1 - \frac{a_k}{z}|^{-\mu_k} < 2^{|\mu_k|}$  for  $k = 1, \dots, n$ .

Thus,

$$|\Psi(z)| < |z|^{-2} 2^{(|-\mu_1| + \dots + |-\mu_n|)} = \frac{M}{|z|^2},$$

where  $M = 2^{(|-\mu_1| + \dots + |-\mu_n|)}$ .  $\diamond$

**CLAIM:**  $\lim_{z \rightarrow \infty} f(z) = W$ , where  $W \in \mathbb{C}$ .

PROOF: We first consider the limit of  $f(x)$  as  $x$  tends to infinity through real values. That is, consider

$$\lim_{x \rightarrow \infty} f(x) = A \int_R^{\infty} \Psi(x) dx + B,$$

where  $R$  is given in (3-24). Letting  $\Psi(x) = u(x) + iv(x)$ , we have

$$\int_R^{\infty} \Psi(x) dx = \int_R^{\infty} u(x) dx + i \int_R^{\infty} v(x) dx.$$

Now,

$$\int_R^{\infty} u(x) dx = \lim_{t \rightarrow \infty} \int_R^t u(x) dx.$$

Using (3-24), we have

$$\int_R^t |u(x)| dx \leq \int_R^t \frac{M}{|x|^2} dx.$$

But  $\int_R^{\infty} \frac{M}{|x|^2} dx$  converges absolutely, hence  $\int_R^{\infty} |u(x)| dx$  converges absolutely. But this implies that  $\int_R^{\infty} u(x) dx$  converges. By a similar procedure,  $i \int_R^{\infty} v(x) dx$  converges.

Thus,

$$\lim_{x \rightarrow \infty} f(x) = A \int_R^{\infty} \Psi(x) dx + B = W, \quad (3-26)$$

where  $W \in \mathbb{C}$ .

Now let  $z$  be a point in the half-plane  $\text{Im}(z) \geq 0$  such that  $\rho = |z| > R$ , where  $R$  is given in (3-24). Then

$$|f(z) - f(\rho)| = \left| A \int_{z_0}^z \Psi(t) dt - A \int_{z_0}^{\rho} \Psi(t) dt \right| = \left| A \int_{\rho}^z \Psi(t) dt \right|, \quad (3-27)$$

where the path of integration is along the arc of the semicircle  $\rho = |z|$  (see Figure 3.3).

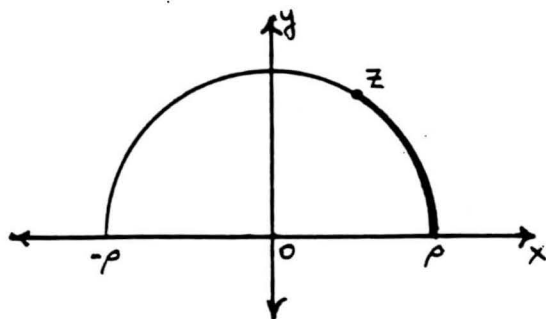

Figure 3.3

If we define a contour  $C_\rho$  by  $z(\theta) = \rho e^{i\theta}$ ,  $\theta \in [0, \pi]$ , (3-27) becomes

$$\begin{aligned} |f(z) - f(\rho)| &= \left| A \int_\rho^z \Psi(t) dt \right| \\ &\leq |A| \int_0^\pi |\Psi(\rho e^{i\theta}) \rho i e^{i\theta}| d\theta \\ &= \rho |A| \int_0^\pi |\Psi(\rho e^{i\theta})| d\theta \\ &\leq \rho |A| \int_0^\pi \frac{M}{|\rho e^{i\theta}|^2} d\theta, \quad \text{by (3-24)} \\ &= \frac{|A|M}{\rho} \theta \Big|_0^\pi \\ &= \frac{|A|M\pi}{\rho}. \end{aligned}$$

Thus,  $f(z) - f(\rho) \rightarrow 0$  as  $\rho = |z| \rightarrow \infty$ . But, as shown in (3-26), as  $\rho \rightarrow \infty$  through real values,  $f(\rho)$  tends to the value  $W$ . Thus,  $f$  must tend to  $W$  as  $z \rightarrow \infty$  in an arbitrary manner in the half-plane  $\text{Im}(z) \geq 0$ . That is,

$$\lim_{z \rightarrow \infty} f(z) = W. \diamond$$

If we define  $f(\infty) = W$ , then  $f(z) = A \int_{z_0}^z \Psi(t) dt + B$  will be continuous at  $z = \infty$ . ■

We now wish to investigate the mapping properties of (3-18). For real  $z$ ,  $z \neq a_k$ , (3-17) becomes

$$\Psi(x) = (x - a_1)^{-\mu_1} \cdots (x - a_n)^{-\mu_n}. \quad (3-28)$$

If  $\xi \in \mathbf{R} \setminus \{a_1, \dots, a_n\}$ , we have

$$\arg(x - \xi) = \begin{cases} \pi, & \text{for } x < \xi \\ 0, & \text{for } x > \xi. \end{cases}$$

Hence,  $\arg(x - \xi)$  is constant for  $x < \xi$ , but decreases by  $\pi$  as  $x$  increases through  $\xi$ . Then in (3-28),  $\arg(x - a_k)$ ,  $k = 1, \dots, n$ , will remain constant in the intervals  $(-\infty, a_1)$ ,  $(a_1, a_2)$ ,  $\dots$ ,  $(a_n, \infty)$ . Thus (3-28) may be written as

$$\Psi(x) = e^{i\theta_j} |\Psi(x)|, \quad a_j < x < a_{j+1}, \quad j = 0, 1, \dots, n, \quad (3-29)$$

where  $a_0 = -\infty$ ,  $a_{n+1} = \infty$ , and

$$\theta_j = -\pi \sum_{k=j+1}^n \mu_k, \quad \theta_n = 0. \quad (3-30)$$



**Lemma 3.5 [12].** The transformation (3-18) maps the interval  $[a_j, a_{j+1}]$  one-to-one onto the line segment  $\overline{f(a_j)f(a_{j+1})}$ ,  $j = 1, \dots, n-1$ . Equation (3-18) also maps the intervals  $(-\infty, a_1]$  and  $[a_n, \infty)$  one-to-one onto the line segments  $\overline{f(\infty)f(a_1)}$  and  $\overline{f(a_n)f(\infty)}$ , respectively.

**PROOF:** Let  $j$  be fixed ( $j = 1, \dots, n-1$ ), and let  $\xi, \hat{\xi}$  be real points such that  $a_j < \xi < \hat{\xi} < a_{j+1}$ . Then,

$$f(\hat{\xi}) - f(\xi) = A \int_{\xi}^{\hat{\xi}} \Psi(x) dx.$$

From (3-29), we have

$$f(\hat{\xi}) - f(\xi) = Ae^{i\theta_j} \int_{\xi}^{\hat{\xi}} |\Psi(x)| dx. \quad (3-31)$$

Since  $\Psi(x) \neq 0$  for all  $x \in (a_j, a_{j+1})$ ,  $f(\hat{\xi}) \neq f(\xi)$ . Also, since  $\theta_j$  is constant for all  $x \in (a_j, a_{j+1})$ ,

$$\arg(f(\hat{\xi}) - f(\xi)) = \arg(A) + \theta_j,$$

is constant for all  $x \in (a_j, a_{j+1})$ .

Since  $f$  is continuous on  $\mathbf{R}$ , letting  $\xi \rightarrow a_j$  and  $\hat{\xi} \rightarrow a_{j+1}$ , the image of  $[a_j, a_{j+1}]$  will correspond to the line segment  $\overline{f(a_j)f(a_{j+1})}$  and this correspondence is one-to-one.

A similar argument holds for the intervals  $(-\infty, a_1]$  and  $[a_n, \infty)$ . ■

**Lemma 3.6 [12].** Let  $w = f(z) = A \int_{z_0}^z \Psi(z) dz + B$ . Then,

$$\arg[f(a_{j+1}) - f(a_j)] - \arg[f(a_j) - f(a_{j-1})] = \pi\mu_j, \quad j = 1, \dots, n,$$

and

$$\arg[f(a_1) - f(\infty)] - \arg[f(\infty) - f(a_n)] = 0,$$

where  $a_0 = a_{n+1} = \infty$ .

**PROOF:** Let  $\xi_0, \xi_1, \dots, \xi_n, \hat{\xi}_0, \hat{\xi}_1, \dots, \hat{\xi}_n$  be real points such that  $-\infty < \xi_0 < \hat{\xi}_0 < a_1, a_j < \xi_j < \hat{\xi}_j < a_{j+1}$  for  $j = 1, \dots, n-1$ , and  $a_n < \xi_n < \hat{\xi}_n < \infty$ . Then from (3-30) and (3-31), we have

$$\arg[f(\hat{\xi}_j) - f(\xi_j)] = \arg(A) + \theta_j = \arg(A) - \pi \sum_{k=j+1}^n \mu_k, \quad j = 1, \dots, n.$$

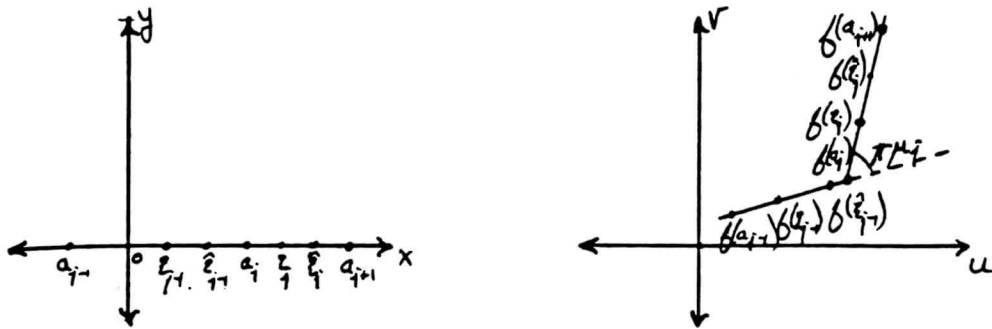

Figure 3.4

Hence, for  $j = 1, \dots, n$ ,

$$\arg [f(\hat{\xi}_j) - f(\xi_j)] - \arg [f(\hat{\xi}_{j-1}) - f(\xi_{j-1})] = \pi \mu_j. \quad (3-32)$$

(See Figure 3.4).

Also,

$$\begin{aligned} \arg[f(\hat{\xi}_0) - f(\xi_0)] - \arg[f(\hat{\xi}_n) - f(\xi_n)] &= \sum_{k=1}^n \arg[f(\hat{\xi}_{k-1}) - f(\xi_{k-1})] - \arg[f(\hat{\xi}_k) - f(\xi_k)] \\ &= \sum_{k=1}^n -\pi \mu_k, \quad \text{from (3-32)} \\ &= -\pi \sum_{k=1}^n \mu_k \\ &= -2\pi, \quad \text{since } \sum_{k=1}^n \mu_k = 2 \\ &= 0 \pmod{2\pi}. \end{aligned}$$

Now, since  $f$  is continuous on  $\mathbf{R}$ , letting  $\xi_j \rightarrow a_j$  and  $\hat{\xi}_j \rightarrow a_{j+1}$  yields

$$\arg[f(a_{j+1}) - f(a_j)] - \arg[f(a_j) - f(a_{j-1})] = \pi \mu_j, \quad j = 1, \dots, n,$$

and

$$\arg[f(a_1) - f(\infty)] - \arg[f(\infty) - f(a_n)] = 0, \quad (3-33)$$

where  $a_0 = a_{n+1} = \infty$ . ■

From Lemmas 3.5 and 3.6, we have that transformation (3-18) maps  $(-\infty, a_1] \cup [a_n, \infty)$  one-to-one onto the line segment  $\overline{f(a_n)f(a_1)}$ , and that the image of  $\mathbf{R} \cup \{\infty\}$  is a closed polygonal curve.

We now restrict the choices of  $a_1, \dots, a_n$  in transformation (3-18) so that this function maps  $\mathbf{R} \cup \{\infty\}$  one-to-one onto a closed polygonal Jordan curve. Then Lemma 3.6 shows that the exterior angle of this polygon at vertex  $f(a_i)$  is  $\pi\mu_i$ . (Recall that for a given polygon with vertex  $A_i$ , the exterior angle at  $A_i$  is defined to be  $\pi\mu_i = \pi - \pi\alpha_i$ , where  $\pi\alpha_i$  is the interior angle at  $A_i$ .)

We are now in a position to prove the converse of Theorem 3.2.

**Theorem 3.7 [12].** *The transformation*

$$w = f(z) = A \int_{z_0}^z (z - a_1)^{-\mu_1} \cdots (z - a_n)^{-\mu_n} dz + B, \quad (3-34)$$

maps  $\overline{\Pi_U} \cup \{\infty\}$  one-to-one and continuously onto a set consisting of a closed polygonal Jordan curve  $P$  and its interior. The upper half-plane  $\Pi_U$  is mapped analytically onto the interior of  $P$ .

**PROOF [3, exercise 12, pp.271-272]:** By Lemma 3.5, (3-34) maps  $\mathbf{R} \cup \{\infty\}$  one-to-one onto  $P$  and by Lemmas 3.3 and 3.4, (3-34) is continuous on  $\overline{\Pi_U} \cup \{\infty\}$  and analytic in the upper half-plane  $\Pi_U$ .

We will now show that (3-34) maps the upper half-plane  $\Pi_U$  one-to-one onto the interior of  $P$ .

We are unable to apply Theorem 1.10 because the real axis does not constitute a simple closed contour of the upper half-plane. However, analogous to the proof of Theorem 1.10, we shall show that the number of times a point  $w_0$  is taken by (3-34) is given by

$$N_{w_0} = \frac{1}{2\pi i} \lim_{r \rightarrow \infty} \int_{-r}^r \frac{f'(z)}{f(z) - w_0} dz.$$

Then we will be able to use the same argument presented in the proof of Theorem 1.10 to conclude that (3-34) is a univalent function mapping the upper half-plane onto the interior of the polygon.

Thus, let  $\mathcal{C}$  be a contour in the upper half plane  $\overline{\Pi_U}$  consisting of the upper half of a circle  $|z| = r$  and a segment  $-r < x < r$  of the  $x$ -axis that contains the points  $a_1, \dots, a_n$ , except

that a small segment about each point is replaced by the upper half of a circle  $|z - a_j| = \rho_j$ , with that segment as its diameter (see Figure 3.5). Also, let  $w_0$  be a point not on  $P$ . Then, from the argument principle, the number of times  $w_0$  is taken by transformation (3-34) interior to  $C$  is given by

$$N_C = \frac{1}{2\pi i} \int_C \frac{f'(z)}{f(z) - w_0} dz = \frac{1}{2\pi i} \int_C \frac{A\Psi(z)}{f(z) - w_0} dz, \quad \text{from (3-19).}$$

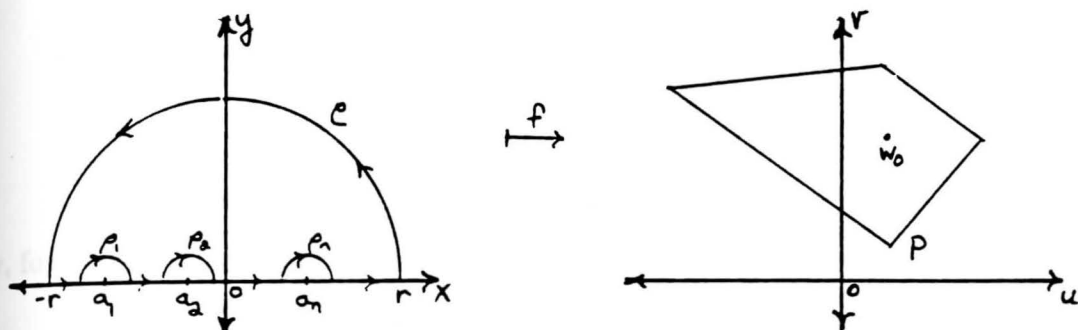

Figure 3.5

CLAIM: The number of times  $w_0$  is taken by transformation (3-34) in the upper half-plane  $\Pi_U$  is

$$N_{w_0} = \frac{1}{2\pi i} \lim_{r \rightarrow \infty} \int_{-r}^r \frac{f'(z)}{f(z) - w_0} dz = \frac{1}{2\pi i} \lim_{r \rightarrow \infty} \int_{-r}^r \frac{A\Psi(z)}{f(z) - w_0} dz. \quad (3-35)$$

PROOF: We first examine the integral

$$\int_{C_r} \frac{A\Psi(z)}{f(z) - w_0} dz, \quad C_r: z(\theta) = re^{i\theta}, \quad \theta \in [0, \pi],$$

as  $r \rightarrow \infty$ . For  $r = |z| > R_1$ , where  $R_1$  is given in (3-24), we have

$$|A\Psi(z)| = |A||\Psi(z)| < \frac{|A|M}{|z|^2} = \frac{|A|M}{r^2}.$$

Now, since  $w_0$  is not a point on  $P$ ,  $\exists \epsilon > 0$  such that  $|f(\infty) - w_0| > 2\epsilon$ . Since  $f$  is continuous at  $z = \infty$ ,  $\exists R_2 > 0$  such that

$$\begin{aligned} r = |z| > R_2 &\implies |f(z) - f(\infty)| < \epsilon \\ &\implies -|f(z) - f(\infty)| > -\epsilon. \end{aligned}$$

Then, for  $r = |z| > R_2$ , we have

$$\begin{aligned} |f(z) - w_0| &= |f(\infty) - w_0 + f(z) - f(\infty)| \\ &\geq |f(\infty) - w_0| - |f(z) - f(\infty)| \\ &> 2\epsilon - \epsilon \\ &= \epsilon. \end{aligned}$$

Thus, for  $r > \max\{R_1, R_2\}$ , we have

$$\left| \int_{C_r} \frac{A\Psi(z)}{f(z) - w_0} dz \right| \leq \frac{|A|M}{r^2\epsilon} r\pi = \frac{|A|M\pi}{r\epsilon},$$

and

$$\lim_{r \rightarrow \infty} \int_{C_r} \frac{A\Psi(z)}{f(z) - w_0} dz = 0. \quad (3-36)$$

Now, for a given  $i$ ,  $i = 1, \dots, n$ , we wish to examine the integral

$$\int_{\rho_i} \frac{A\Psi(z)}{f(z) - w_0} dz, \quad \rho_i: z(\theta) = |z - a_i|e^{i\theta}, \quad \theta \in [0, \pi],$$

as  $\rho_i \rightarrow 0$ . Observe that  $|\Psi(z)|$  can be written as

$$|\Psi(z)| = |\psi(z)||z - a_i|^{-\mu_i},$$

where  $\psi(z) = \prod_{\substack{k=1 \\ k \neq i}} (z - a_k)^{-\mu_k}$  is a continuous function at  $z = a_i$ . Consequently, for  $\delta_1 > 0$ ,  $\exists \eta_1 > 0$  such that

$$\begin{aligned} \rho_i = |z - a_i| < \eta_1 &\implies \delta_1 > |\psi(z) - \psi(a_i)| \geq |\psi(z)| - |\psi(a_i)| \\ &\implies \delta_1 + |\psi(a_i)| > |\psi(z)|. \end{aligned}$$

Thus, for  $\rho_i = |z - a_i| < \eta_1$ ,

$$|A\Psi(z)| = |A||\psi(z)||z - a_i|^{-\mu_i} < |A|(\delta_1 + |\psi(a_i)|)\rho_i^{-\mu_i}.$$

Again, since  $w_0$  is not a point on  $P$ ,  $\exists \delta_2 > 0$  such that  $|f(a_i) - w_0| > 2\delta_2$ . Since  $f$  is continuous at  $z = a_i$ ,  $\exists \eta_2 > 0$  such that

$$\begin{aligned} \rho = |z - a_i| < \eta_2 &\implies |f(z) - f(a_i)| < \delta_2 \\ &\implies -|f(z) - f(a_i)| > -\delta_2. \end{aligned}$$

Then, for  $\rho_i = |z - a_i| < \eta_2$ , we have

$$\begin{aligned} |f(z) - w_0| &= |f(z) - f(a_i) + f(a_i) - w_0| \\ &\geq |f(a_i) - w_0| - |f(z) - f(a_i)| \\ &> 2\delta_2 - \delta_2 \\ &= \delta_2. \end{aligned}$$

Thus, for  $\rho_i < \min\{\eta_1, \eta_2\}$ , we have

$$\left| \int_{\rho_i} \frac{A\Psi(z)}{f(z) - w_0} dz \right| < \frac{|A|(\delta_1 + |\psi(a_i)|)\rho_i^{-\mu_i}}{\delta_2} \rho_i \pi = \frac{|A|(\delta_1 + |\psi(a_i)|)\pi \rho_i^{1-\mu_i}}{\delta_2},$$

and since  $1 - \mu_i > 0$ ,

$$\lim_{\rho_i \rightarrow 0} \int_{\rho_i} \frac{A\Psi(z)}{f(z) - w_0} dz = 0. \quad (3-37)$$

Letting  $r \rightarrow \infty$  and  $\rho_i \rightarrow 0$ ,  $i = 1, \dots, n$ , (3-36) and (3-37) imply that the number of times  $w_0$  is taken by transformation (3-34) in the upper half-plane  $\Pi_U$  is

$$N_{w_0} = \frac{1}{2\pi i} \lim_{r \rightarrow \infty} \int_{-r}^r \frac{f'(z)}{f(z) - w_0} dz = \frac{1}{2\pi i} \lim_{r \rightarrow \infty} \int_{-r}^r \frac{A\Psi(z)}{f(z) - w_0} dz. \quad \diamond$$

Now, let  $w = f(z)$ ,  $dw = f'(z) dz$ . Then we have

$$N_{w_0} = \frac{1}{2\pi i} \lim_{r \rightarrow \infty} \int_{-r}^r \frac{f'(z)}{f(z) - w_0} dz = \frac{1}{2\pi i} \int_P \frac{dw}{w - w_0}.$$

Using the same argument given in the proof of Theorem 1.10, we may conclude that

$$w = f(z) = A \int_{z_0}^z (z - a_1)^{-\mu_1} \cdots (z - a_n)^{-\mu_n} dz + B,$$

maps the upper half-plane  $\Pi_U$  one-to-one onto the interior of  $P$ . Theorem 3.7 is thus proved. ■

The transformation (3-34) is called the Schwarz-Christoffel transformation of the upper half-plane onto the interior of a polygon. Formulas of type (3-34) are called Schwarz-Christoffel formulas. In Chapter 4, we will examine some generalizations of transformation (3-34).

## CHAPTER 4

### Variations of the Schwarz-Christoffel Transformation

In this chapter, we wish to develop some variations of the Schwarz-Christoffel transformation. We begin by first restating Theorem 3.2:

**Theorem 3.2 [8].** Suppose  $w = f(z)$  is a univalent function which maps  $\Pi_U = \{z : \text{Im}(z) > 0\}$  onto the interior of a (bounded) closed polygonal Jordan curve  $P$  with interior angles  $\alpha_1\pi, \dots, \alpha_n\pi$  ( $0 < \alpha_k < 2$ ,  $k = 1, \dots, n$ ), and suppose the points  $a_1, \dots, a_n$  ( $-\infty < a_1 < \dots < a_n < +\infty$ ) correspond to the vertices of  $P$ . Then

$$w = f(z) = A \int_{z_0}^z (t - a_1)^{-\mu_1} \dots (t - a_n)^{-\mu_n} dt + B, \quad (3-16)$$

where  $\mu_k = 1 - \alpha_k$ ,  $z_0 \in \bar{\Pi}_U = \{z : \text{Im}(z) \geq 0\}$ , and  $A, B \in \mathbf{C}$ .

Formula (3-16) gives the explicit form of a univalent function mapping the upper half-plane onto the interior of a given polygon. By modifying the proof of Theorem 3.2, it is possible to obtain the explicit form of a univalent function mapping the upper half-plane onto the exterior of a polygon. Namely,

**Theorem 4.1 [8].** Suppose  $w = f(z)$  is a univalent function which maps  $\Pi_U$  onto the exterior of a (bounded) closed polygonal Jordan curve  $P$  with interior angles  $\alpha_1\pi, \dots, \alpha_n\pi$  ( $0 < \alpha_k < 2$ ,  $k = 1, \dots, n$ ), and suppose the points  $a_1, \dots, a_n$  ( $-\infty < a_1 < \dots < a_n < +\infty$ ) correspond to the vertices of  $P$ . Then

$$w = f(z) = A \int_{z_0}^z \frac{(t - a_1)^{\mu_1} \dots (t - a_n)^{\mu_n}}{(t - \beta)^2 (t - \bar{\beta})^2} dt + B, \quad (4-1)$$

where  $\mu_k = 1 - \alpha_k$ ,  $z_0 \in \bar{\Pi}_U$ ,  $A, B \in \mathbf{C}$ , and  $\beta$  ( $\text{Im} \beta > 0$ ) is the inverse image of  $\infty$ .

**PROOF [8,10]:** Since the mapping  $w = f(z)$  is conformal at  $z = \beta$  and  $f(\beta) = \infty$ ,  $f$  must have a simple pole at  $z = \beta$ . Thus, it must be of the form

$$f(z) = \frac{\phi(z)}{z - \beta}, \quad (4-2)$$

where  $\phi$  is analytic at  $z = \beta$  and  $\phi(\beta) \neq 0$ . Then,

$$\begin{aligned} f'(z) &= -(z - \beta)^{-2} \phi(z) + (z - \beta)^{-1} \phi'(z), \\ f''(z) &= 2(z - \beta)^{-3} \phi(z) - 2(z - \beta)^{-2} \phi'(z) + (z - \beta)^{-1} \phi''(z), \end{aligned}$$

and,

$$\begin{aligned} \frac{f''(z)}{f'(z)} &= \frac{2(z - \beta)^{-3} \phi(z) - 2(z - \beta)^{-2} \phi'(z) + (z - \beta)^{-1} \phi''(z)}{-(z - \beta)^{-2} \phi(z) + (z - \beta)^{-1} \phi'(z)} \\ &= \frac{2\phi(z) - 2(z - \beta)\phi'(z) + (z - \beta)^2 \phi''(z)}{(z - \beta)[(z - \beta)\phi'(z) - \phi(z)]} \\ &= -\frac{2}{z - \beta} + \frac{(z - \beta)\phi''(z)}{(z - \beta)\phi'(z) - \phi(z)}. \end{aligned}$$

Thus,

$$g_1(z) = \frac{f''(z)}{f'(z)} + \frac{2}{z - \beta}, \quad (4-3)$$

is analytic at  $z = \beta$  and  $g_1(\beta) = 0$ .

Now, if we apply the symmetry principle to  $w = f(z)$  and the upper half-plane,  $f$  will have a simple pole at  $z = \bar{\beta}$ . Consequently, by a similar procedure as above, the function

$$g_2(z) = \frac{f''(z)}{f'(z)} + \frac{2}{z - \bar{\beta}}, \quad (4-4)$$

will be analytic at  $z = \bar{\beta}$  and  $g_2(\bar{\beta}) = 0$ .

Observe that the mapping  $w = f(z)$  will map the real axis onto the polygon  $P$ . Consequently, we may use the proof of Theorem 3.2 to conclude that the function

$$\Phi(z) = \frac{f''(z)}{f'(z)} - \sum_{k=1}^n \frac{\mu_k}{z - a_k} + \frac{2}{z - \beta} + \frac{2}{z - \bar{\beta}}, \quad (4-5)$$

is analytic in  $\mathbf{C}_\infty$  and  $\Phi(\infty) = 0$ . It should be noted that since  $w = f(z)$  maps the real axis to the exterior of the polygon  $P$ , the angles  $\alpha_k \pi$ ,  $k = 1, \dots, n$ , used in the proof of Theorem 3.2 are replaced by  $2\pi - \alpha_k \pi = \pi(2 - \alpha_k)$ . Thus, the quantities  $\mu_k = 1 - \alpha_k$  used in the proof of Theorem 3.2 will be replaced by

$$1 - (2 - \alpha_k) = -(1 - \alpha_k) = -\mu_k, \quad k = 1, \dots, n.$$



Since  $\Phi$  is analytic in  $\mathbf{C}_\infty$  and  $\Phi(\infty) = 0$ ,  $\Phi \equiv 0$  by Liouville's theorem. Thus, (4-5) yields

$$\frac{f''(z)}{f'(z)} = \sum_{k=1}^n \frac{\mu_k}{z - a_k} - \frac{2}{z - \beta} - \frac{2}{z - \bar{\beta}}.$$

Integrating, we have

$$w = f(z) = A \int_{z_0}^z \frac{(t - a_1)^{\mu_1} \cdots (t - a_n)^{\mu_n}}{(t - \beta)^2 (t - \bar{\beta})^2} dt + B,$$

where  $A, B \in \mathbf{C}$ . ■

Formulas (3-16) and (4-1) hold when  $a_k \neq \infty$ ,  $k = 1, \dots, n$ . However, (3-16) and (4-1) can be modified to accept the point at infinity as shown in the following theorem.

**Theorem 4.2 [8].** *If  $a_n = \infty$ , then formulas (3-16) and (4-1) are replaced by*

$$w = f(z) = A \int_{z_0}^z (t - a_1)^{-\mu_1} \cdots (t - a_{n-1})^{-\mu_{n-1}} dt + B, \quad (4-6)$$

and,

$$w = f(z) = A \int_{z_0}^z \frac{(t - a_1)^{\mu_1} \cdots (t - a_{n-1})^{\mu_{n-1}}}{(t - \beta)^2 (t - \bar{\beta})^2} dt + B, \quad (4-7)$$

respectively.

**PROOF:** We shall first consider formula (4-6). The Möbius transformation

$$z = T(\hat{z}) = a_n - \frac{1}{\hat{z}}, \quad (4-8)$$

is an automorphism of the upper half-plane and maps  $\hat{z} = \infty$  onto  $z = a_n$ . Composing (3-16) with (4-8) yields

$$\hat{f}(\hat{z}) = f(T(\hat{z})) = A \int_{z_0}^{a_n - \hat{z}^{-1}} (t - a_1)^{-\mu_1} \cdots (t - a_n)^{-\mu_n} dt + B.$$

Under the change of variable  $t = a_n - \hat{t}^{-1}$ , we have

$$\hat{f}(\hat{z}) = A \int_{\hat{z}_0}^{\hat{z}} \left( a_n - a_1 - \frac{1}{\hat{t}} \right)^{-\mu_1} \cdots \left( a_n - a_{n-1} - \frac{1}{\hat{t}} \right)^{-\mu_{n-1}} \left( -\frac{1}{\hat{t}} \right)^{-\mu_n} \hat{t}^{-2} d\hat{t} + B,$$

where  $\hat{z}_0 = \frac{1}{a_n - z_0}$ . Hence,

$$\begin{aligned} \hat{f}(\hat{z}) &= A \int_{\hat{z}_0}^{\hat{z}} \left( -\frac{1}{\hat{t}} \right)^{-\mu_n} \hat{t}^{-2} \prod_{k=1}^{n-1} \left( a_n - a_k - \frac{1}{\hat{t}} \right)^{-\mu_k} d\hat{t} + B \\ &= A \int_{\hat{z}_0}^{\hat{z}} \left( -\frac{1}{\hat{t}} \right)^{-\mu_n} \hat{t}^{-2} \prod_{k=1}^{n-1} \left( -\frac{1}{\hat{t}} \right)^{-\mu_k} [1 + (a_k - a_n)\hat{t}]^{-\mu_k} d\hat{t} + B. \end{aligned} \quad (4-9)$$

Since  $\sum_{k=1}^n \mu_k = 2$ , we have  $\prod_{k=1}^n \left(-\frac{1}{\hat{t}}\right)^{-\mu_k} = \left(-\frac{1}{\hat{t}}\right)^{-2}$ , and (4-9) becomes

$$\begin{aligned} \hat{f}(\hat{z}) &= A \int_{\hat{z}_0}^{\hat{z}} \left(-\frac{1}{\hat{t}}\right)^{-2} \hat{t}^{-2} \prod_{k=1}^{n-1} [1 + (a_k - a_n)\hat{t}]^{-\mu_k} d\hat{t} + B \\ &= A \int_{\hat{z}_0}^{\hat{z}} (-1)^{-2} \left(\frac{1}{\hat{t}}\right)^{-2} \hat{t}^{-2} \prod_{k=1}^{n-1} (a_k - a_n)^{-\mu_k} \left[\frac{1}{a_k - a_n} + \hat{t}\right]^{-\mu_k} d\hat{t} + B \\ &= \hat{A} \int_{\hat{z}_0}^{\hat{z}} \prod_{k=1}^{n-1} \left[\frac{1}{a_k - a_n} + \hat{t}\right]^{-\mu_k} d\hat{t} + B, \end{aligned} \quad (4-10)$$

where  $\hat{A} = A \prod_{k=1}^{n-1} (a_k - a_n)^{-\mu_k}$ . Letting  $\hat{a}_k = \frac{1}{a_n - a_k}$ , (4-10) becomes

$$\hat{f}(\hat{z}) = \hat{A} \int_{\hat{z}_0}^{\hat{z}} (\hat{t} - \hat{a}_1)^{-\mu_1} \dots (\hat{t} - \hat{a}_{n-1})^{-\mu_{n-1}} d\hat{t} + B,$$

which is of the form (4-7).

Formula (4-7) is proved in the same fashion. ■

As our final generalization of the Schwarz-Christoffel transformation, we have

**Theorem 4.3 [8].** If  $\Pi_U = \{z : \text{Im}(z) > 0\}$  is replaced by  $K = \{z : |z| < 1\}$ , then formula (3-16) becomes

$$w = f(z) = A \int_{z_0}^z (t - b_1)^{-\mu_1} \dots (t - b_{n-1})^{-\mu_{n-1}} dt + B, \quad (4-6)$$

where  $z_0 \in \bar{K}$ ,  $z \in K$ , and the inverse images of the vertices of the polygon are of the form  $b_1 = e^{i\theta_1}, \dots, b_n = e^{i\theta_n}$ ,  $0 \leq \theta_k < 2\pi$  ( $k = 1, \dots, n$ ) and  $\theta_1 < \dots < \theta_n$ . Formula (4-1) becomes

$$w = f(z) = A \int_{z_0}^z (t - b_1)^{\mu_1} \dots (t - b_n)^{\mu_n} \frac{dt}{t^2} + B, \quad (4-11)$$

where  $z = 0$  is the inverse image of the point at infinity.

**PROOF:** We shall first show that (3-16) retains the same form. Consider the Möbius transformation

$$z = T(\hat{z}) = i \left( \frac{1 + \hat{z}}{1 - \hat{z}} \right), \quad (4-12)$$

which maps  $|\hat{z}| < 1$  onto  $\text{Im}(z) > 0$  (by Theorem 2.13). Now observe that if  $t = i \left( \frac{1+i}{1-i} \right)$ , we have

$$\begin{aligned}
 (t - a_k)^{\mu_k} &= \left[ i \left( \frac{1 + \hat{t}}{1 - \hat{t}} \right) - a_k \right]^{\mu_k} \\
 &= \left( \frac{1}{1 - \hat{t}} \right)^{\mu_k} [i + \hat{t}i - a_k(1 - \hat{t})]^{\mu_k} \\
 &= \left( \frac{1}{1 - \hat{t}} \right)^{\mu_k} [\hat{t}(a_k + i) - (a_k - i)]^{\mu_k} \\
 &= \left( \frac{a_k + i}{1 - \hat{t}} \right)^{\mu_k} \left[ \hat{t} - \frac{a_k - i}{a_k + i} \right]^{\mu_k} \\
 &= \left( \frac{a_k + i}{1 - \hat{t}} \right)^{\mu_k} [\hat{t} - b_k]^{\mu_k}, \quad \text{where } b_k = \frac{a_k - i}{a_k + i}, \quad |b_k| = 1,
 \end{aligned}$$

and

$$dt = \frac{2i}{(1 - \hat{t})^2} d\hat{t}.$$

Now, with the change of variable  $t = i \left( \frac{1+i}{1-i} \right)$ , composing (3-16) with (4-12) yields

$$\hat{f}(\hat{z}) = f(T(\hat{z})) = A \int_{\hat{z}_0}^{\hat{z}} \frac{2i}{(1 - \hat{t})^2} \prod_{k=1}^n \left( \frac{a_k + i}{1 - \hat{t}} \right)^{-\mu_k} (\hat{t} - b_k)^{-\mu_k} d\hat{t} + B, \quad (4-13)$$

where  $\hat{z}_0 = \frac{z_0 - i}{z_0 + i}$ . Simplifying, we have

$$\hat{f}(\hat{z}) = \hat{A} \int_{\hat{z}_0}^{\hat{z}} \frac{2i}{(1 - \hat{t})^2} \prod_{k=1}^n \left( \frac{1}{1 - \hat{t}} \right)^{-\mu_k} (\hat{t} - b_k)^{-\mu_k} d\hat{t} + B.$$

Since  $\sum_{k=1}^n \mu_k = 2$ , we have  $\prod_{k=1}^n \left( \frac{1}{1 - \hat{t}} \right)^{-\mu_k} = \left( \frac{1}{1 - \hat{t}} \right)^{-2}$ , and

$$\begin{aligned}
 \hat{f}(\hat{z}) &= \hat{A} \int_{\hat{z}_0}^{\hat{z}} \frac{2i}{(1 - \hat{t})^2} \left( \frac{1}{1 - \hat{t}} \right)^{-2} \prod_{k=1}^n (\hat{t} - b_k)^{-\mu_k} d\hat{t} + B \\
 &= \hat{A} \int_{\hat{z}_0}^{\hat{z}} \prod_{k=1}^n (\hat{t} - b_k)^{-\mu_k} d\hat{t} + B.
 \end{aligned}$$

That is,

$$w = f(z) = A \int_{z_0}^z (t - b_1)^{-\mu_1} \dots (t - b_n)^{-\mu_n} dt + B,$$

which is of the form (3-16).

To prove (4-11), we require a Möbius transformation which maps  $K$  onto  $\Pi_U$  and the point  $\hat{z} = 0$  to  $z = \beta$ . Using Theorem 2.13, we see that this transformation will be given by

$$z = S(\hat{z}) = \frac{\hat{z}\bar{\beta} - \beta}{\hat{z} - 1}. \quad (4-14)$$

By using (4-14), formula (4-11) is proved in a similar fashion as above. ■

## CHAPTER 5

### Examples

In this chapter, we wish to consider some examples illustrating the results of the previous chapters. We begin with

**Example 5.1.** Construct a conformal map between the regions shown in Figure 5.1.

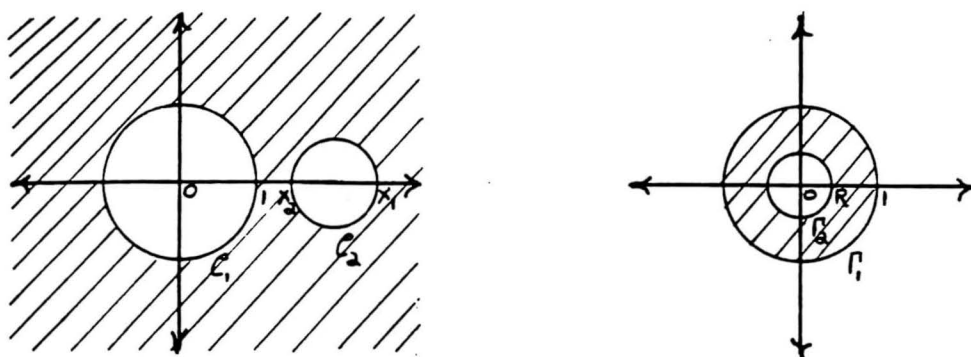

Figure 5.1

Let  $C_1$  represent the circle  $|z| = 1$ ,  $C_2$  the circle with center on the real axis passing through  $x_1$  and  $x_2$ ,  $\Gamma_1$  the circle  $|w| = 1$ , and  $\Gamma_2$  the circle  $|w| = R$ . Our construction will center on finding a Möbius transformation which will map  $|z| > 1$  onto  $|w| < 1$ , and  $C_2$  onto  $\Gamma_2$ . We first note that for any  $a$  satisfying  $1 < x_2 < a < x_1$ , the Möbius transformation

$$w = T(z) = \frac{z - a}{az - 1}, \quad (5-1)$$

will map  $|z| > 1$  onto  $|w| < 1$ .

We now wish to determine  $a$  so that  $C_2$  will map onto  $\Gamma_2$ . Since  $a$  is real,  $T$  will map conjugate points onto conjugate points, and  $T(C_2)$  will be bisected by the real axis. Thus, the diameter  $x_2 \leq a \leq x_1$  of  $C_2$  will map onto the diameter  $u_1 \leq u \leq u_2$  of  $T(C_2)$ . Hence, the center  $w_0$  of  $T(C_2)$  satisfies  $2w_0 = u_1 + u_2 = T(x_2) + T(x_1)$ . Now, if we let  $w_0 = 0$ , then  $C_2$  will map onto  $\Gamma_2$ , and

$$0 = T(x_2) + T(x_1) = \frac{x_2 - a}{ax_2 - 1} + \frac{x_1 - a}{ax_1 - 1}. \quad (5-2)$$

Simplifying, we obtain

$$a^2(x_1 + x_2) - 2a(x_1x_2 + 1) + (x_1 + x_2) = 0. \quad (5-3)$$

By the quadratic formula,

$$a = r_1 = \frac{x_1x_2 + 1 + \sqrt{(x_1^2 - 1)(x_2^2 - 1)}}{x_1 + x_2}, \quad \text{or} \quad a = r_2 = \frac{x_1x_2 + 1 - \sqrt{(x_1^2 - 1)(x_2^2 - 1)}}{x_1 + x_2}. \quad (5-4)$$

Observe that  $r_1r_2 = 1$  and  $r_1 > r_2$ . Hence,  $r_1 > 1$  and  $r_2 < 1$ . Since we require that  $a > 1$ ,

$$a = r_1 = \frac{x_1x_2 + 1 + \sqrt{(x_1^2 - 1)(x_2^2 - 1)}}{x_1 + x_2}. \quad (5-5)$$

Thus, our transformation becomes

$$w = T(z) = \frac{z - a}{az - 1}, \quad (5-6)$$

where  $a = \frac{x_1x_2 + 1 + \sqrt{(x_1^2 - 1)(x_2^2 - 1)}}{x_1 + x_2}$ .

The value for  $R$  is given by

$$R = T(x_1) = \frac{x_1 - a}{ax_1 - 1}. \quad \blacksquare \quad (5-7)$$

As an example of the use of conformal mappings in applications, we consider the following Dirichlet problem:

**Example 5.2.** Find a function  $H(x, y)$  that is harmonic in the region shown in Figure 5.2a and satisfies the boundary conditions  $H(x, y) = 0$  on the unit circle and  $H(x, y) = V$ , ( $V \in \mathbf{R}$ ), on the circle passing through the points  $x_1$  and  $x_2$ ,  $x_1, x_2 \in \mathbf{R}$ .

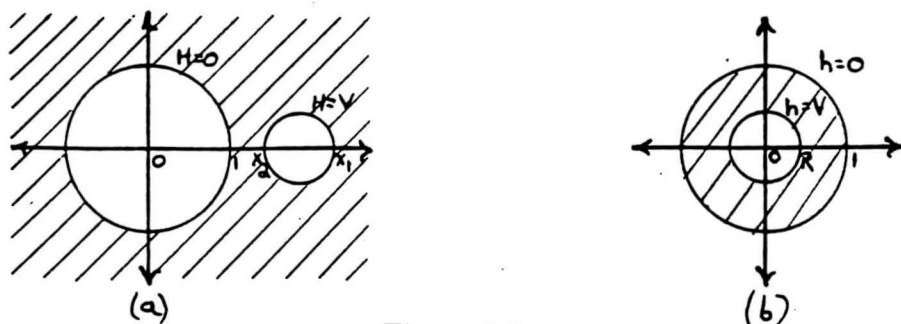

Figure 5.2

First, consider the Dirichlet problem applied to the region shown in Figure 5.2b. In this region, we wish to find a harmonic function  $h(u, v)$  such that  $h(u, v) = 0$  on the circle  $|w| = 1$  and  $h(u, v) = V$  on the circle  $|w| = R$ . Due to the symmetry of the annulus, it can be shown [5] that the harmonic function satisfying these boundary conditions is given by

$$h(u, v) = \frac{V}{\log R} \log \sqrt{u^2 + v^2} = \frac{V}{\log R} \log |w|, \quad (5-8)$$

where  $w = u + iv$ .

Now observe from Example 5.1 that the transformation

$$w = \frac{z - a}{az - 1}, \quad a = \frac{x_1 x_2 + 1 + \sqrt{(x_1^2 - 1)(x_2^2 - 1)}}{x_1 + x_2},$$

maps the region in Figure 5.2a onto the annulus shown in Figure 5.2b. Thus, by Theorems 1.11 and 1.12, the harmonic function satisfying the boundary conditions shown in Figure 5.2a is given by

$$H(x, y) = h[u(x, y), v(x, y)] = \frac{V}{\log R} \log \left| \frac{z - a}{az - 1} \right|, \quad (5-9)$$

where  $a = \frac{x_1 x_2 + 1 + \sqrt{(x_1^2 - 1)(x_2^2 - 1)}}{x_1 + x_2}$  and  $R = \frac{x_1 - a}{ax_1 - 1}$ . ■

We now consider some examples of the Schwarz-Christoffel transformation.

**Example 5.3 [16].** Show that the function

$$w = f(z) = \int_0^z \frac{dt}{(1 - t^n)^{\frac{2}{n}}}, \quad (5-10)$$

maps  $|z| < 1$  onto the interior of a regular polygon of order  $n$ .

Consider the  $n$ th roots of unity  $b_1 = 1, b_2 = \omega, \dots, b_n = \omega^{n-1}$ , where  $\omega = \exp\left(\frac{2\pi i}{n}\right)$ .

Then the transformation

$$f(z) = \int_0^z \frac{dt}{(t - b_1)^{\frac{2}{n}} \cdots (t - b_n)^{\frac{2}{n}}}, \quad (5-11)$$

will map  $|z| < 1$  onto the interior of an  $n$ -sided polygon that has interior angles  $\alpha_k \pi = \pi - \frac{2\pi}{n} = (1 - \frac{2}{n})\pi$ ,  $k = 1, \dots, n$ . Now, note that

$$\prod_{k=1}^n (t - b_k) = \prod_{k=1}^n \left( t - \exp\left(\frac{2\pi i(k-1)}{n}\right) \right) = t^n - 1,$$

and

$$(t^n - 1)^{\frac{2}{n}} = (-1)^{\frac{2}{n}} (1 - t^n)^{\frac{2}{n}} = (1 - t^n)^{\frac{2}{n}}.$$

Thus, (5-11) becomes

$$f(z) = \int_0^z \frac{dt}{(1 - t^n)^{\frac{2}{n}}}. \quad (5-12)$$

We now

CLAIM: Equation (5-12) maps  $|z| = 1$  onto a regular polygon of order  $n$ .

PROOF: Since (5-12) maps  $|z| = 1$  onto an  $n$ -sided polygon whose interior angles are all equal, we need only show that the lengths of the sides of the polygon are equal.

Consider the side  $\overline{f(b_{k-1})f(b_k)}$  of the polygon. It has length given by

$$|f(b_k) - f(b_{k-1})| = \left| \int_{b_{k-1}}^{b_k} \frac{dt}{(1 - t^n)^{\frac{2}{n}}} \right|. \quad (5-13)$$

If we perform the substitution  $s = \omega t$ , the integral becomes

$$\int_{b_{k-1}}^{b_k} \frac{dt}{(1 - t^n)^{\frac{2}{n}}} = \frac{1}{\omega} \int_{b_{k-1}\omega}^{b_k\omega} \frac{ds}{(1 - (\frac{s}{\omega})^n)^{\frac{2}{n}}} = \frac{1}{\omega} \int_{b_{k-1}\omega}^{b_k\omega} \frac{ds}{(1 - e^{-2\pi i s})^{\frac{2}{n}}}. \quad (5-14)$$

Observe that  $b_k\omega = \omega^{k-1}\omega = \omega^k = b_{k+1}$ , and  $b_{k-1}\omega = \omega^{k-2}\omega = \omega^{k-1} = b_k$ . Hence, (5-14) becomes

$$\int_{b_{k-1}}^{b_k} \frac{dt}{(1 - t^n)^{\frac{2}{n}}} = \frac{1}{\omega} \int_{b_k}^{b_{k+1}} \frac{ds}{(1 - s^n)^{\frac{2}{n}}},$$

and,

$$|f(b_k) - f(b_{k-1})| = \left| \int_{b_{k-1}}^{b_k} \frac{dt}{(1 - t^n)^{\frac{2}{n}}} \right| = \left| \frac{1}{\omega} \int_{b_k}^{b_{k+1}} \frac{ds}{(1 - s^n)^{\frac{2}{n}}} \right| = |f(b_{k+1}) - f(b_k)|.$$

Thus, the lengths of the sides of the polygon are equal and (5-12) maps  $|z| = 1$  onto a regular polygon of order  $n$ .  $\diamond$

We conclude that the function

$$w = f(z) = \int_0^z \frac{dt}{(1 - t^n)^{\frac{2}{n}}},$$

maps  $|z| < 1$  onto the interior of a regular polygon of order  $n$ .



Since  $f(0) = 0$ , the polygon is centered at the origin and the radius of the circumscribed circle is

$$R = \int_0^1 \frac{dt}{(1-t^n)^{\frac{2}{n}}},$$

and the length of a given side is

$$l = 2R \sin \frac{\pi}{n} = 2 \sin \frac{\pi}{n} \int_0^1 \frac{dt}{(1-t^n)^{\frac{2}{n}}}. \quad \blacksquare$$

By an argument similar to that used above, it is easily seen that the function

$$w = f(z) = \int_0^z \frac{(1-t^n)^{\frac{2}{n}}}{t^2} dt, \quad (5-15)$$

will map  $|z| < 1$  onto the exterior of a regular polygon of order  $n$ .

**Example 5.5** [10, exercise 5, pp.197-198]. Show that

$$w = f(z) = \int_0^z \frac{(1-t^5)^{\frac{2}{5}}}{(1+t^5)^{\frac{4}{5}}} dt, \quad (5-16)$$

maps  $|z| < 1$  onto the pentagram shown in Figure 5.3.



Figure 5.3

Consider the 10th roots of unity  $b_0 = 1, b_1 = \omega, \dots, b_9 = \omega^9$ , where  $\omega = \exp(\frac{2\pi i}{10}) = \exp(\frac{\pi i}{5})$ . Then the transformation

$$f(z) = \int_0^z \frac{\prod_{k=0}^4 (t - b_{2k})^{\frac{2}{5}}}{\prod_{k=0}^4 (t - b_{2k+1})^{\frac{4}{5}}} dt, \quad (5-17)$$

will map  $|z| < 1$  onto the interior of a 10-sided polygon  $P$  that has interior angles  $\alpha_k \pi = \pi + \frac{2\pi}{5} = \frac{7\pi}{5}$  at the vertices  $f(b_k)$ ,  $k = 0, 2, 4, 6, 8$ , and interior angles  $\alpha_k \pi = \pi - \frac{4\pi}{5} = \frac{\pi}{5}$  at the vertices  $f(b_k)$ ,  $k = 1, 3, 5, 7, 9$ . Now, note that

$$\prod_{k=0}^4 (t - b_{2k}) = \prod_{k=0}^4 (t - \exp(\frac{2k\pi i}{5})) = t^5 - 1,$$

and

$$\prod_{k=0}^4 (t - b_{2k+1}) = \prod_{k=0}^4 (t - \exp(\frac{(2k+1)\pi i}{5})) = t^5 + 1.$$

Hence, (5-17) becomes

$$f(z) = \int_0^z \frac{(t^5 - 1)^{\frac{2}{5}}}{(t^5 + 1)^{\frac{4}{5}}} dt = \int_0^z \frac{(1 - t^5)^{\frac{2}{5}}}{(1 + t^5)^{\frac{4}{5}}} dt. \quad (5-18)$$

Since  $f(0) = 0$ , the polygon  $P$  will be the pentagram shown in Figure 3 if  $|f(b_k)| = c_1$  for  $k = 1, 3, 5, 7, 9$ , and  $|f(b_k)| = c_2$ , where  $c_1 \neq c_2$ , for  $k = 0, 2, 4, 6, 8$ . Now,

$$|f(b_1)| = \left| f\left(\exp\left(\frac{\pi i}{5}\right)\right) \right| = \left| \int_0^{e^{\frac{\pi i}{5}}} \frac{(1 - t^5)^{\frac{2}{5}}}{(1 + t^5)^{\frac{4}{5}}} dt \right|. \quad (5-19)$$

Under the substitution  $s = \exp(\frac{2\pi i}{5})t$ , the integral is

$$\int_0^{e^{\frac{\pi i}{5}}} \frac{(1 - t^5)^{\frac{2}{5}}}{(1 + t^5)^{\frac{4}{5}}} dt = \exp(-\frac{2\pi i}{5}) \int_0^{e^{\frac{3\pi i}{5}}} \frac{(1 - e^{-2\pi i} s^5)^{\frac{2}{5}}}{(1 + e^{-2\pi i} s^5)^{\frac{4}{5}}} ds.$$

Then (5-19) becomes

$$|f(b_1)| = \left| \int_0^{e^{\frac{\pi i}{5}}} \frac{(1 - t^5)^{\frac{2}{5}}}{(1 + t^5)^{\frac{4}{5}}} dt \right| = \left| e^{-\frac{2\pi i}{5}} \int_0^{e^{\frac{3\pi i}{5}}} \frac{(1 - s^5)^{\frac{2}{5}}}{(1 + s^5)^{\frac{4}{5}}} ds \right| = |f(b_3)|.$$

Repeating this process yields

$$|f(b_1)| = |f(b_3)| = \dots = |f(b_9)|.$$

Similarly, we will have

$$|f(b_0)| = |f(b_2)| = \dots = |f(b_8)|.$$

s the function

$$w = f(z) = \int_0^z \frac{(1-t^5)^{\frac{2}{5}}}{(1+t^5)^{\frac{4}{5}}} dt,$$

s  $|z| < 1$  onto the interior of the pentagram shown in Figure 3. ■

For our final example, we wish to use the Schwarz-Christoffel transformation to map the upper half-plane onto a polygon with vertices at infinity. Although the theory presented in chapters 3 and 4 concerned bounded polygons, the Schwarz-Christoffel transformation can be modified to accept unbounded polygons [8]. For our final example, we shall consider an unbounded polygon as a limiting form of a bounded polygon.

**Example 5.6 [3].** Find a function mapping the upper half-plane onto the domain  $\{z : 0 < \text{Im}(z) < \pi\}$  (See Figure 5.4).

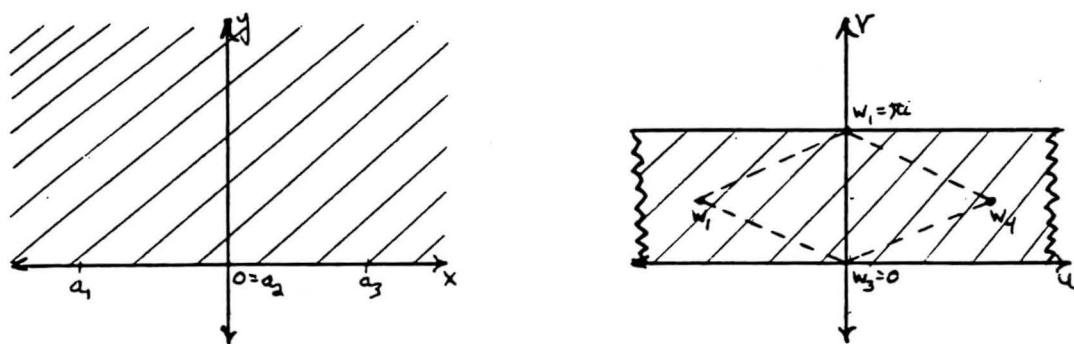

Figure 5.4

Consider the rhombus with vertices at the points  $w_1 = \pi i$ ,  $w_2$ ,  $w_3 = 0$ , and  $w_4$ . We consider  $D$  as the limiting form of this rhombus as  $\text{Re}(w_2)$  and  $\text{Re}(w_4)$  approach  $-\infty$  and  $+\infty$  respectively. In the limit the exterior angles will be

$$\mu_1\pi = 0, \quad \mu_2\pi = \pi, \quad \mu_3\pi = 0, \quad \mu_4\pi = \pi.$$

Using the values  $z_0 = 1$ ,  $a_2 = 0$ ,  $a_3 = 1$ , and  $a_4 = \infty$  in formula (4-6), we have

$$w = f(z) = A \int_1^z (t - a_1)^0 (t - 0)^{-1} (t - 1)^0 dt + B. \quad (5-20)$$

Simplifying, we have

$$w = f(z) = A \int_1^z \frac{dt}{t} + B = A \log z + B. \quad (5-21)$$

We now need to determine the values of the constants  $A$  and  $B$ . Since the image of the point  $a_3 = 1$  is to be  $w_3 = 0$ ,  $B$  must be 0. Now, when  $\hat{x} > 0$ , the point  $f(\hat{x}) = A \log \hat{x}$  will lie on the real axis. Hence,  $A$  must be a real constant. Also, the image of the point  $z = a_1$  is  $w = \pi i$ . That is,

$$\pi i = A \log a_1. \quad (5-22)$$

Since  $a_1$  is negative, (5-22) becomes

$$\pi i = A \log a_1 = A \log |a_1| + A\pi i.$$

By equating real and imaginary parts, we have  $|a_1| = 1$  and  $A = 1$ . Thus, the function mapping the upper half-plane onto  $D$  is

$$w = \log z. \quad \blacksquare \quad (5-23)$$

## CHAPTER 6

### Conclusion

The Riemann mapping theorem guarantees the existence of a univalent function that maps the unit disk onto a simply connected domain  $D$ , but it does not provide a technique for the actual construction of this function. However, using the results of the previous chapters, we are able to construct that function when  $D$  is circular or polygonal. By a technique somewhat similar to that given in Chapter 3, it is possible to construct a univalent function mapping the upper half-plane onto the interior of a circular polygon, that is, a polygon whose sides consist of circular arcs [6,10].

The question now arises as to whether or not it is possible to construct a univalent function, guaranteed by the Riemann mapping theorem, that maps an arbitrary simply connected domain onto the unit disk. A technique has been developed to answer this question, but its use is severely restricted due to the complicated expressions involved. (For a thorough discussion of this technique, see Hille [6] or Nehari [10].)

## REFERENCES

- [1.] BAK, J., and D. J. NEWMAN, "Complex Analysis," Springer-Verlag, New York, 1982. QA331.B23.
- [2.] BIEBERBACH, L., "Conformal Mapping," Chelsea Publishing Co., New York, 1964. QA646.B515.
- [3.] CHURCHILL, R. V., and J. W. BROWN, "Complex Variables and Applications," 4th ed., McGraw-Hill Book Company, New York, 1984. QA331.C524.
- [4.] DEPREE, J. D., and C. C. OEHRING, "Elements of Complex Analysis," Addison-Wesley Publishing Company, Inc., Reading, Mass., 1969. QA331.D53.
- [5.] HENRICI, P., "Applied and Computational Complex Analysis," vol. 1, John Wiley & Sons, Inc., New York, 1974. QA331.H453.
- [6.] HILLE, E., "Analytic Function Theory," vols. 1 and 2, 2nd ed., Chelsea Publishing Co., New York, 1973. QA331.H54.
- [7.] LEVINSON, N., and R. M. REDHEFFER, "Complex Variables," Holden-Day Inc., San Francisco, 1970. QA331.L47.
- [8.] MARKUSHEVICH, A. I., "Theory of Functions of a Complex Variable," 3 vols. in one, Chelsea Publishing Co., New York, 1977. QA331.M3713.
- [9.] MARSDEN, J. E., and M. J. HOFFMAN, "Basic Complex Analysis," W. H. Freeman and Company, New York, 1987. QA331.M378.
- [10.] NEHARI, Z., "Conformal Mapping," Dover Publications, Inc., New York, 1952. QA646.N35.
- [11.] ———, "Introduction to Complex Analysis," Allyn and Bacon, Inc., Boston, 1961. QA331.N4.
- [12.] PENNISI, L. L., "Elements of Complex Variables," Holt, Rinehart and Winston, Inc., New York, 1963. QA331.P3.
- [13.] RUBENFELD, L. A., "A First Course in Applied Complex Variables," John Wiley & Sons, Inc., New York, 1985. QA331.R83.
- [14.] SAFF, E. B., and A. D. SNIDER, "Fundamentals of Complex Analysis for Mathematics, Science, and Engineering," Prentice-Hall, Inc., Englewood Cliffs, N. J., 1976. QA300.S18.
- [15.] SAKS, S., and A. ZYGMUND, "Analytic Functions," Hafner Publishing Company, New York, 1952. QA331.S315.
- [16.] SANSONE, G., and J. GERRETSEN, "Lectures on the Theory of Functions of a Complex Variable," vol. 2, Wolters Noordhoff Publishing, Groningen, The Netherlands, 1969. QA331.S337.